



LUND UNIVERSITY

REHABCON - Strategy for maintenance and rehabilitation in concrete structures, Work Package 2.3 : evaluations of alternative repair and upgrading options : Final Report

Fagerlund, Göran

2004

[Link to publication](#)

Citation for published version (APA):

Fagerlund, G. (2004). *REHABCON - Strategy for maintenance and rehabilitation in concrete structures, Work Package 2.3 : evaluations of alternative repair and upgrading options : Final Report*. (Report TVBM (Intern 7000-rapport); Vol. 7177). Division of Building Materials, LTH, Lund University.

Total number of authors:

1

General rights

Unless other specific re-use rights are stated the following general rights apply:

Copyright and moral rights for the publications made accessible in the public portal are retained by the authors and/or other copyright owners and it is a condition of accessing publications that users recognise and abide by the legal requirements associated with these rights.

- Users may download and print one copy of any publication from the public portal for the purpose of private study or research.
- You may not further distribute the material or use it for any profit-making activity or commercial gain
- You may freely distribute the URL identifying the publication in the public portal

Read more about Creative commons licenses: <https://creativecommons.org/licenses/>

Take down policy

If you believe that this document breaches copyright please contact us providing details, and we will remove access to the work immediately and investigate your claim.

LUND UNIVERSITY

PO Box 117
221 00 Lund
+46 46-222 00 00

LUND INSTITUTE OF TECHNOLOGY

Division of Building Materials

EC Innovation and SME Programme
Project No. IPS-2000-0063

REHABCON
**Strategy for maintenance and
rehabilitation in concrete structures**

Work Package 2.3
**Evaluation of alternative repair and
upgrading options**

Final Report

Editor: Göran Fagerlund



TVBM-7177

June 2004

Lund, Sweden

LUND INSTITUTE OF TECHNOLOGY

Division of Building Materials

EC Innovation and SME Programme
Project No. IPS-2000-0063

REHABCON
Strategy for maintenance and
rehabilitation in concrete structures

Work Package 2.3
Evaluation of alternative repair and
upgrading options

Final Report

Editor: Göran Fagerlund

TVBM-7177

June 2004

Lund, Sweden

ISSN: 0348-7911 TVBM

Lunds Tekniska Högskola
Byggnadsmaterial
Box 118
www.byggnadsmaterial.lth.se

Tel: 046-2227415
Fax: 046-2224427

221 00 LUND

Preface to project REHABCON

The EU-project REHABCON “*Strategy for maintenance and rehabilitation in concrete structures*” started in May 2001 and terminated in May 2004. The following partners participated:

Sweden

Research organizations:

Swedish Cement and Concrete Research Institute (CBI). Coordinator of the project
Div. of Building Materials, Lund Institute of Technology (LIT)
Vattenfall Utveckling (VUAB)

Owners:

Swedish National Road Administration (SNRA)
Swedish National Rail Administration (BV)

Contractor:

NCC AB (NCC)

Material supplier:

SIKA Sverige AB (SIKA)

Spain

Research organization:

Instituto de ciencias de la construcción Eduardo Torroja del CSIC (IETcc)

Contractor:

Geotecnia y Cimientos s.a. (GEOCISA)

United Kingdom:

Research organizations:

British Research Establishment Limited (BRE)
Transport Research Laboratory (TRL)

Owner:

National Car Parks Limited (NCP)

The project was divided in a number of Work Packages (WP:s):

- WP 2.1: “*Market research and data collection*”.
Responsible partner, IETcc.
- WP2.2: “*Definition of performance requirements*”
Responsible partner BRE.
- WP2.3: “*Evaluation of alternative repair and upgrading options*”.
Responsible partner LIT.
- WP2.4: “*Site trials and field evaluation*”
Responsible partner NCC.
- WP3.1: “*Development of integrated management strategy*”.
Responsible partner VUAB.
- WP4.1: “*Production of guidance manuals and complementary documents*”
Responsible partner GEOCISA.

There were additional Work Packages for administration and dissemination.

Work in the project has resulted in a number of Deliverables given to the European Commission:

- [1] WP 2.1: *Market Review*. IETcc. Madrid, December 2002.
- [2] WP 2.2: *Performance Requirements*. BRE. Watford, November 2002
- [3] WP 2.3: *Evaluation with regard to durability and service life*. LIT. Lund, December 2003.
- [4] WP 2.3: *Evaluation with regard to structural stability*. LIT. Lund, December 2003.
- [5] WP 2.3: *Evaluation with regard to execution of work*. LIT and Geocisa, Lund December 2003.
- [6] WP 2.3: *Evaluation with regard to environment and health*. SIKA. Stockholm, December 2003
- [7] WP 2.3: *Economical evaluation of different systems applied to different types of damage and structure*. VUAB. Älvkarleby, December, 2003.
- [8] WP 3.1: *Integrated management system for concrete structures – Optimisation of measures*. VUAB. Älvkarleby, December 2003.

Three more Deliverables will be given to the Commission in June 2004:

- [9] WP 2.3: *Final report on the evaluation of alternative repair and upgrading options*. LIT, Lund, June 2004 (The present report)
- [10] WP 2.4: *Final report on site trials and field evaluation*. NCC. Malmö, to be published June 2004.
- [11] WP 4.1: *Guidance Manual*. GEOCISA. Madrid, to be published June 2004.

Preface to the present report

The present report is the final report from Work Package 2.3 “*Evaluation of alternative repair and upgrading options*”.

WP 2.3 was led by Div. Building Materials, Lund Institute of Technology (LIT).

Partners LIT, NCC, GEOCISA, SIKA, VUAB, CBI and BRE have contributed to the report (For abbreviations of partners see *Preface to project REHABCON* above). Persons involved in the report are:

Main Document

Chapters 1 and 2:	Author: Göran Fagerlund (LIT)
Chapter 3:	Authors: Manouchehr Hassanzadeh and Göran Fagerlund (LIT)
Chapter 4:	Author: Manouchehr Hassanzadeh (LIT)
Chapter 5:	Author: Kajsa Byfors (SIKA)
Chapter 6:	Author: Manouchehr Hassanzadeh (VUAB)
Chapter 7:	Author: Örjan Petersson (CBI)

ANNEX 1 Authors: Table 1 and 2: Mårten Janz (CBI)
Table 1(parts): Göran Fagerlund (LIT)

ANNEX 2

Main text:	Author: Göran Fagerlund (LIT)
Appendix 1:	Authors: Mårten Janz (CBI), Lars-Olof Nilsson (LIT)
Appendix 2:	Author: Lars-Olof Nilsson (LIT)
Appendix 3:	Author: Lars-Olof Nilsson (LIT)
Appendix 4:	Author: Göran Fagerlund (LIT)

ANNEX 3 Authors: Roberto Caprile and Jan Molander (NCC)

ANNEX 4 General structure of the chapter: Manouchehr Hassanzadeh (LIT)
Main author: Ramón Muñoz Carreño (GEOCISA)
Contributions: Manouchehr Hassanzadeh, Göran Fagerlund (LIT)

ANNEX 5 Author: Kajsa Byfors (SIKA)

ANNEX 6 Author: Manouchehr Hassanzadeh (VUAB)

ANNEX 7 Authors: Örjan Petersson (CBI), Stuart Mattew (BRE)

I thank all partners for their constructive cooperation in Work Package 2.3 of REHABCON, and for their contributions to this Final Report.

Lund, June 7, 2004

Göran Fagerlund



EU-Project REHABCON
Strategy for Maintenance and Rehabilitation in Concrete
Structures

WP 2.3
EVALUATION OF ALTERNATIVE REPAIR AND
UPGRADING OPTIONS

Final report

CONTENTS

This deliverable is composed of one Main Document and 7 Annexes.

Main Document:

**“EVALUATION OF ALTERNATIVE REPAIR AND UPGRADING
OPTIONS”**

Edited by partner LIT.

Contributions by partners LIT (Chapters 1, 2, 3, 4), SIKA (Chapter 5), VUAB (Chapter 6),
CBI (Chapter 7)

Annex 1:

**“REPAIR PRINCIPLES AND REPAIR METHODS FOR DIFFERENT TYPES OF
DAMAGE - QUALITATIVE EVALUATION OF REPAIR METHODS AND
MATERIALS”**

Worked out by partners CBI and LIT

Annex 2:

**“EVALUATION WITH REGARD TO SERVICE LIFE. QUANTITATIVE
EVALUATION”**

Worked out by partners LIT and CBI

Annex 3:

**“EVALUATION WITH REGARD TO STRUCTURAL STABILITY AND SAFETY.
PROCEDURES”**

Worked out by partner NCC

Annex 4:

**“EVALUATION WITH REGARD TO EXECUTION OF WORK. EVALUATION OF
FREQUENT ACTIONS”**

Worked out by partner Geocisa with contributions from LIT

Annex 5:

“EVALUATION WITH REGARD TO ENVIRONMENT AND HEALTH”

Worked out by partner SIKA

Annex 6:

“EVALUATION WITH REGARD TO ECONOMY. APPLICATION EXAMPLE”

Worked out by partner VUAB

Annex 7:

“CONSIDERATIONS TO NON-TECHNICAL ISSUES”

Worked out by partner CBI with contributions from BRE

MAIN DOCUMENT

EVALUATION OF ALTERNATIVE REPAIR AND UPGRADING OPTIONS

Abstract

This Main Document presents tools that can be used when evaluating and selecting the most appropriate repair option for a specific structure.

The evaluation of the selected repair options will be considered with regard to:

- (i) service life and durability
- (ii) structural stability and safety
- (iii) execution of work
- (iv) environmental effect
- (v) economy/cost
- (vi) factors of a non-technical nature.

The Main Document only presents general procedures. More detailed information is presented in *Annexes 1 to 7*.

Contents	Page
1 General procedures for evaluation of repair	4
1.1 Definition of “repair”	4
1.2 Required information for evaluation	4
1.3 Steps in the evaluation	5
1.4 Selection of alternative repair methods/systems	6
1.5 Evaluation parameters	6
1.6 Different levels of evaluation	7
1.7 Example of evaluation principles	8
2 Evaluation with regard to service life	10
2.1 Definition of service life	10
2.2 Basic service life requirements	11
2.3 Operative requirements constituting service life	11
2.4 Evaluation procedure – levels	13
2.5 Evaluation on Level 1: Approved solutions	13
2.6 Evaluation on Level 2: Qualitative evaluation	14
2.7 Evaluation on Level 3: Quantitative evaluation - service life design	15
3 Evaluation with regard to structural stability and safety	18
3.1 Structural stability before repair	18
3.2 Design of the repaired structure with regard to structural stability	18
3.3 Long-term structural stability - service life	20
3.4 Repair methods of interest for structural analysis – Examples	20
3.5 Example: Repair of beams	21
4 Evaluation with regard to execution of work	23
4.1 Introduction	23
4.2 Topics of repair action	24
4.3 Evaluation of topics of repair action – principles	24
4.4 Evaluation parameters	26
4.5 Evaluation of execution of work – Example	26
5 Evaluation with regard to environment and health	29
5.1 Introduction	29
5.2 Methodology for evaluation – principles	29
5.3 Evaluation of concrete repair with regard to ecology	31
5.4 Evaluation of concrete repair with regard to indoor environment	32
5.5 Evaluation of concrete repair – health and safety during execution of work	33
5.6 Example of an evaluation	34
6 Evaluation with regard to economy	37
6.1 Introduction	37
6.2 LCC and its components	38
6.3 Methodology	39
6.4 Basic calculation factors	41
6.5 Examples of repair costs	42
Addendum: Illumination of equation 6.5	44
7 Considerations to non-technical issues (NTI)	45
References	48

1 GENERAL PROCEDURES FOR EVALUATION OF REPAIR

1.1 Definition of “repair”

The definition of “*repair*” (or “*repair method/system*”) is:

- (i) the combination of *repair material* and *the existing damaged concrete structure* including also *interfaces* between repair material and existing structure.
- (ii) any *process* used for stopping ongoing destruction of the existing structure not involving application of new material. The most important examples are: (i) reducing moisture content to safe level, (ii) cathodic protection, (iii) chloride extraction, (iv) corrosion inhibitors, (v) re-alkalisation.

1.2 Required information for evaluation

Evaluation of a repair system is based on the following background information and knowledge:

1: Type of damage, cause of damage, location of damage

It is assumed that type, cause and extent of damage have been established. Principles and practical methods for analysis of the present and residual status of a damaged structure are described in documents worked out within the European project “CONTECVET” [1]. The damage types considered in these documents are:

- Reinforcement corrosion, [1.a]
- Alkali silica reaction (ASR), [1.b]
- Frost attack (internal and external), [1.c]
- Leaching, [1.d]

There are also other possible damage types; some are described in *Annexes 1 and 2*.

On basis of this analysis it can be decided whether immediate repair shall be made, or if it can be postponed.

Also the location of damage must be known, since it affects the selection of proper repair method. Location can be; (i) under water, (ii) on vertical surfaces, (iii) on top surfaces, (iv) on bottom surfaces, (v) at high altitude.

2: Requirements on the repaired structure and the repair procedure

Repair, and the evaluation of this, must be based on a number of requirements, primarily defined by *society*, *owner*, and *user* of the structure. Requirements to be considered at the evaluation can be divided in two types:

- (i) Functional requirements on the *structure after repair*. Some of these requirements are primarily defined by the society, like requirements for structural safety. Other requirements are primarily defined by the owner, like requirements for serviceability (“general functionality”, deformation, appearance, maintenance cost, etc.) There are also requirements indirectly defined by the user, like experience of safety, reliable function, etc.

- (ii) Requirements on the *repair procedure*. Some requirements are defined by the society, like requirements related to environmental impact and health hazard during execution of work. Other requirements are defined by the owner, like requirements on cost of repair. There are also other requirements of non-technical nature on the repair procedure, such as requirements related to disturbance of normal activities related to the repair work; e.g. disturbance of traffic, noise, disturbance of residents etc.

It is important that as many of these requirements as possible can be expressed in *quantitative* and *measurable* terms. If this is not made, the evaluation becomes more uncertain. For requirements that cannot be easily expressed in precise quantitative terms pseudo-quantitative methods have to be used.

For functional requirements of the first type, it is important to consider that the requirements have to be defined by the owner for a prescribed *life time*. This is important, since almost all properties determining structural stability/safety, or serviceability, declines with time. The evaluation of service life of a repair method is often the most difficult part of an evaluation.

3: Data related to old structure, repair method, and repair material

An important basis for evaluation is *data* of various kinds; primarily material data on mechanical properties, permeability, durability, composition, etc. of repair materials, and data for the old structure required for analysing the short-term and long-term interaction between old concrete and repair. Evaluation of repair, therefore, relies upon the existence of *good test methods* for obtaining data.

Furthermore, data are required for the *cost* of different activities involved in the repair. Data are also required concerning *environmental effects* of execution of repair, and on chemicals used in repair materials.

4: Existence of theories for analysing the interaction between repair and structure

Evaluation also relies upon the existence of good theories for *analysing interaction* (short-term and long-term) between existing concrete and repair material. Thus, an evaluation cannot only be based on an analysis of the repair material itself, but must be based on an *understanding of the interaction*. This is particularly important for analysing service life and structural stability.

1.3 Steps in the evaluation

En evaluation of repair is made in three consecutive steps:

Step1: Selecting a suitable *repair principle* relevant for the actual structure, the actual damage, and the actual requirements.

Step 2: Selecting a suitable *repair method/system* within the repair principle chosen.

Step 3: Selecting a suitable *repair material* (material composition, or brand) to be used in the repair method chosen, or selecting a suitable type and brand of the *process* chosen for stopping continuing destruction.

In most cases, steps 1 and 2 in the evaluation are fairly simple and can be based on “common sense” and previous experience.

Step 3 is much more complex since different repair materials with different composition used in the same repair method can lead to quite different function of the repaired structure. Step 3 requires extensive data concerning the status of the old structure, and concerning mechanical and physical properties of the repair material. Data of this type are needed also for a *qualitative* evaluation, based on previous experience of interactions between old damaged structures and repair materials of different type. Data are absolutely necessary for *quantitative* evaluations of structural stability, serviceability and durability of the repaired structure.

Thus a vital element in the evaluation of repair is to select not only a suitable repair principle and method but also a suitable repair material that makes it possible to fulfil all requirements on the repaired structure.

1.4 Selection of alternative repair methods/systems

The most difficult task at selection of a repair method is to weigh different requirements against each other in order to find the “optimum” solution. Normally, however, requirements for *structural safety* and *service life* dominate. Thus, the most natural repair principle and repair methods are often fairly easy to find. Thereby, also the most natural repair method can be selected.

The suitable repair method depends on the cause, type and location of damage. For every damage type and cause, there are normally only a few repair principles, and a few main repair methods available. These repair principles, and main methods, are described in the tables in *Annex 1*.

1.5 Evaluation parameters

Once, the most suitable repair method or system has been identified, it is important to consider that there are many *variants* within the same repair method. Therefore, main requirements other than those related to safety and service life, such as requirements with regard to environment, economy, simplicity of execution etc., might often be decisive for the final selection of materials and methods. The best material to be used in the actual case is decided on the basis of an evaluation of the alternatives. Information enabling such an evaluation for different objectives is described below in paragraphs 2 to 7.

Primarily, a repair method is evaluated with regard to the following 5 basic parameters:

1. service life/durability
2. structural stability/safety
3. execution of work
4. environmental effects
5. economy/cost

Additionally, factors of a *non-technical nature*, such as disturbances of different kind during repair work, have to be considered in the evaluation.

1.6 Different levels of evaluation

The evaluation of a repair method or repair material can be made on three different levels:

Level 1: Approved solutions

Level 2: Qualitative evaluation

Level 3: Quantitative evaluation

Level 1: Approved solutions

The most simple procedure is to rely upon experience from previously executed repair and, therefore, select repair methods and materials that have proved to work sufficiently well in the past, for example by yielding long service life of the repaired structure, by being simple to execute, by being cost effective, and by having a low impact on environment..

The method is defensive, since it will conserve old techniques. New repair materials and principles cannot be evaluated this way, and might therefore be effectively prevented from being used.

Level 2: Qualitative evaluation

Based on experience from previous repairs, and on “semi-quantitative”, and/or qualitative reasoning, the experienced engineer might in many cases make a good evaluation of a repair system and a repair material in a given situation.

Annex 1 gives examples of such qualitative evaluations. The most frequent repair principles and methods for different types of repair are listed, together with a short description of advantages and problems.

Based on test results of materials to be used, combined with some elementary calculations, the effect on *structural stability* directly after repair can be evaluated. Using simplified analysis, some account can also be taken of future changes in the repaired structure, i.e. to *the service life*. The calculations used are fairly rough, however. No consideration to changes in moisture state of the structure after repair and its effect on durability is made. Synergistic effects of two or more destructive processes going on at the same time are also neglected.

Information furnished by the manufacturer on potential *health hazard* and *environmental impact* should be used for comparison of materials. Using such procedures, different materials can be rated as regards their capability to fulfil the requirements.

The drawback of a level 2 evaluation is similar to a level 1 evaluation; new repair methods might be stopped due to lack of reliable information.

Level 3: Quantitative evaluation

Evaluation on levels 1 and 2 are well suited for evaluations of execution of work, economy, environmental impact, and other requirements of non-technical character. These types of evaluation, however, give no real quantitative information on *future changes* in fundamental properties of the repaired structure; viz. structural stability and serviceability. Thus, they cannot be used for a more precise evaluation of service life of the repaired structure. During the last decades, methods for service life calculations, “*service life design*”, have been developed for new structures. The same principles can also be used for the calculation of service life of repaired structures.

Inputs in these types of calculation are:

- Material data valid at time of repair for repair materials, original structural concrete, and interfaces between these materials. Test methods are required for obtaining these data.
- Theories for calculating structural interaction between repair and the original structural concrete. Different theories might be valid for different types of repair system and different types of structural member; beam, column, slab, pre-stressed component, etc.
- Theories for calculating future changes in material properties determining structural capacity and serviceability of the repaired structure; primarily, strength and stiffness of concrete, erosion of concrete cross-section, and corrosion rate of reinforcement. Such theories are based on knowledge of the *destructive processes*. *Test methods* are required for determining properties of importance for deterioration of the repaired structure.

Quantitative evaluation with regard to *service life* is further described in paragraph 2 and *Annex 2*. Quantitative evaluation with regard to *structural stability and deformation* is treated in paragraph 3 and *Annex 3*.

1.7 Example of evaluation principles

Principles:

The evaluation principles are exemplified in Figure 1.1. When the cause of damage and type of damage are known, and the functional requirements of the repaired structure have been established, some alternative repair methods exist. For each method there are normally many repair materials (or processes) available. The method and the material (process) selected are evaluated with regard to the 5 characteristics shown in paragraph 4, and also for other characteristics, of non-technical nature. Basic principles for evaluation are given in paragraphs 2 to 7 below. More detailed methods for evaluation are shown in *Annexes 2 – 6*.

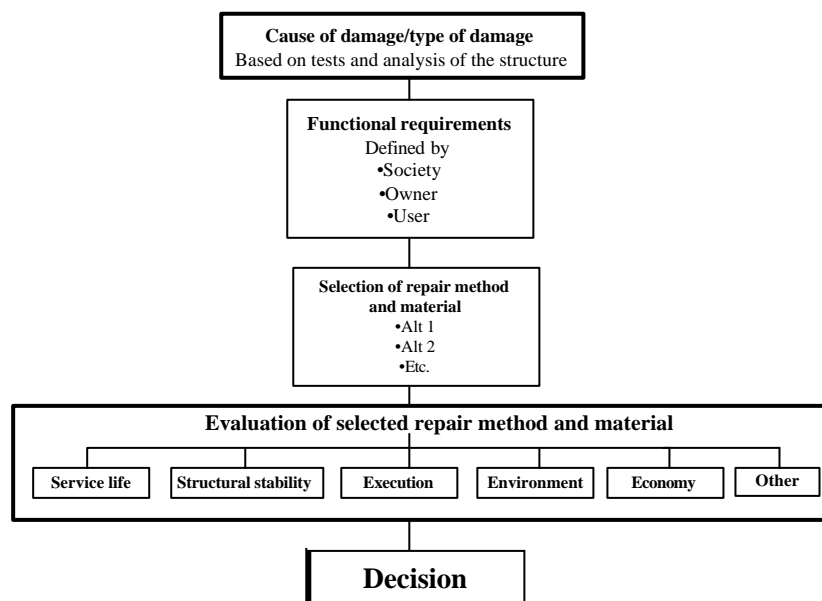

Figure 1.1: Evaluation of a repair method. Principles.

Example:

A more detailed example is shown in Figure 1.2. The damage cause is chloride-induced corrosion. The damage type is spalling of cover. Functional requirements of importance for evaluation of the five criteria are indicated in the figure. The selected repair method is replacement of the cover with new concrete cast in-situ. The quality (composition) and thickness of the new concrete must be such that the requirements for service life and structural stability are fulfilled. That this is the case must be verified at the evaluation.

Only evaluation factors for the criteria “service life” and “strength” are indicated in the figure. Evaluation factors for the criteria “execution”, “environment”, “economy”, and “non-technical issues” are omitted.

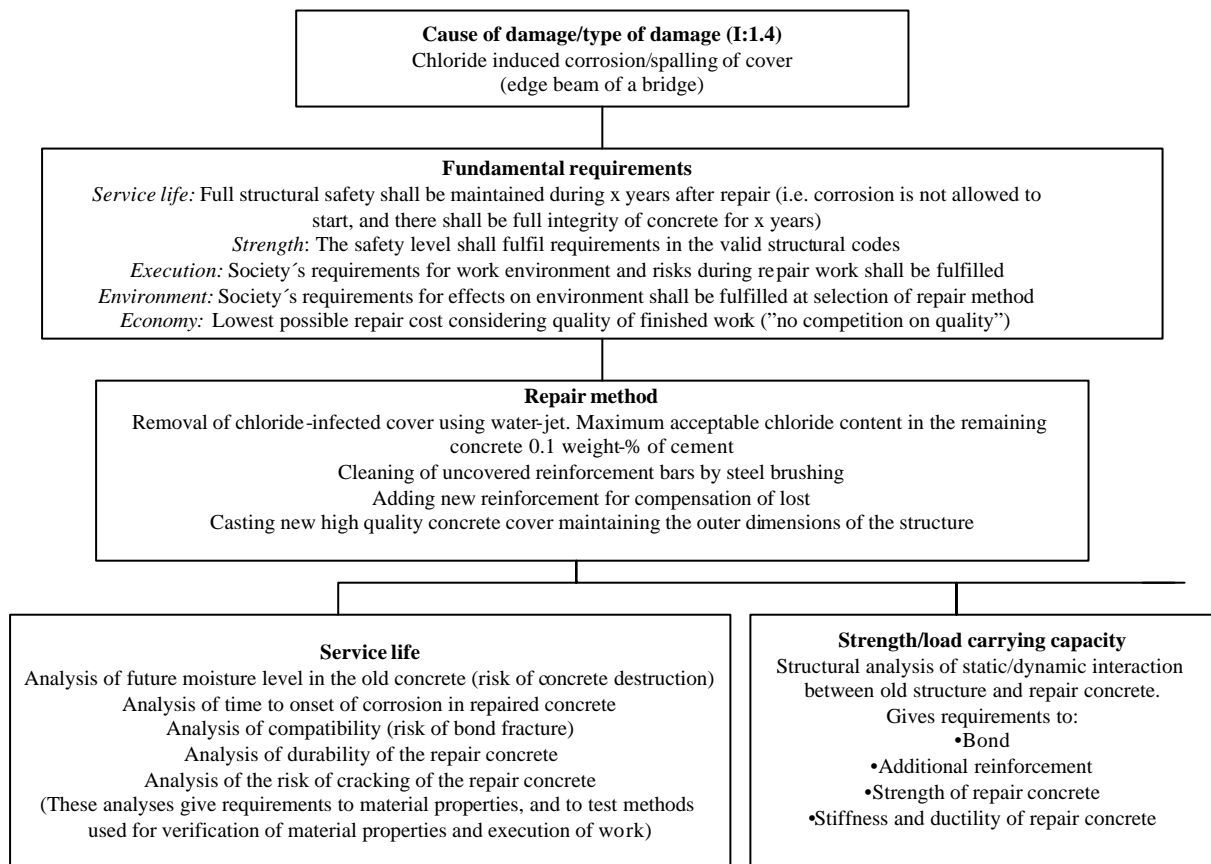

Figure 1.2: Example of the contents in an evaluation of a method and a material.

2 EVALUATION WITH REGARD TO SERVICE LIFE

Additional and more detailed information is given in *Annex 2*.

2.1 Definition of service life

A fundamental requirement of a repair is that the structure maintains its full function during a minimum period, defined by the owner. This is illustrated in Figure 2.1. At time t the structure has reached the lowest acceptable function F_{\min} . After repair, function is raised to the initial value, or to any other value defined by the owners requirements. In most cases, the repaired structure will gradually reduce its function, due to the influence of aggressive agents in the external environment. Depending on the repair method used, this new degradation can be more or less rapid. At time t_2 the structure once again no longer fulfils the requirements. Therefore, it needs further improvement. The extension of service life due to repair is Δt , which should be in conformity with the value defined by the owner in his requirements.

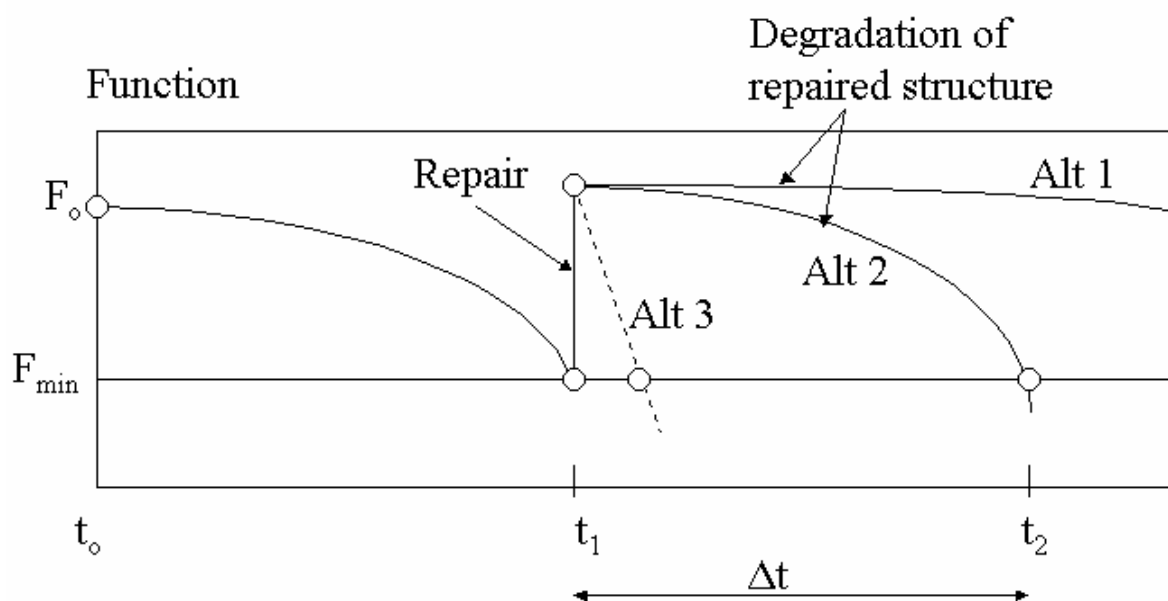

Figure 2.1: Repair and degradation of the repaired structure.

“Function”, or “quality”, can be defined in different ways. It might be related to *structural safety*, or *load-carrying capacity*. Or it can be related to “*serviceability*”, by which is meant the capability of the structure to fulfil requirements that are not directly coupled to structural stability, like water tightness, appearance, deformation, cracking, etc. The actual minimum acceptable function, or quality, has to be defined by the owner, preferably in *quantitative and measurable terms*.

Selection of repair systems should be based on an evaluation of their capability to fulfil the owner’s requirements for service life. Such an evaluation is often very complicated, since it means that the complex *interaction* between the repair material and the old damaged structure often has to be evaluated with regard to service life, in addition to evaluating the repair material by itself.

Different combinations of repair and damaged concrete structure will give different values of the service life. This is illustrated by Figure 2.1. Repair **Alt 2** gives shorter service life than **Alt 1**, because for example:

1. the *repair material* used in Alt 2 has in itself lower durability than the repair material used in Alt 1. Thus, the protecting capability of the material used in Alt 2 is more rapidly reduced with time. One example is when further chemical surface attack is to be stopped by a protective surface coating. Alt 2 is a coating with lower chemical resistance than Alt 1.
2. the *repair system* Alt 2 does not protect the old concrete from further deterioration as effectively as the repair system Alt 1. Thus, when Alt 2 is used, the previous deterioration process in the old structure continues, although at a retarded rate. When Alt 1 is used the future deterioration is effectively hindered. One example is when further reinforcement corrosion is to be stopped by a new cover. Then, Alt 2 is a cover which in itself allows more rapid penetration of carbonation or chloride than Alt 1.

In severe cases, the repair might even *accelerate destruction* of the old concrete by initiating new types of destruction, see **Alt 3** in Figure 2.1. One example is when a structure with moderate frost resistance is repaired by a dense polymer surface coating, or by a layer of polymer-based concrete. Then, moisture might accumulate beneath the dense coating leading to rapid and severe frost damage of the old concrete. This type of *damage stimulated by repair* has frequently been observed in practice [2]. The risks have also been demonstrated in the lab. [3].

2.2 Basic service life requirements

The basic requirement is that the repaired structure shall maintain full function during the prescribed service life. By “function” is primarily meant requirements for *structural stability* and *serviceability*.

The repaired structure will in most cases be exposed to the same aggressive agents as it was before repair. It might even be, that exposure is aggravated after repair. *The service life of the repaired structure, therefore, depends on the ability of the repair system to stop, or sufficiently retard, future deterioration of the concrete structure.* When assessing the ability of a certain repair system to fulfil this requirement it is assumed that the concrete quality in the existing structure is normally of low, or fairly low quality compared with the repair concrete, unless otherwise is proven by testing.

2.3 Operative requirements constituting service life

For a good evaluation it is required that the basic service life requirement is broken down into *a number of measurable quantities*, many of which are related to durability and transport properties of the repair material. The manner in which such a transformation to measurable properties can be made is exemplified by the repaired slab in Figure 2.2. The slab has been damaged by internal frost and by reinforcement corrosion induced by carbonation, and/or chloride penetration. Repair is made by two alternatives: (i) removing old damaged chloride contaminated, and/or carbonated, cover and replacing with new cover, (ii) application of a coating without removing old concrete.

Requirements coupled to service life of the repaired concrete are:

1. A maximum allowable *diffusion rate of carbon dioxide* in the new cover (or in the coating.). The diffusion rate depends on the moisture level in the repair materials. The lower the amount of lime able to carbonate, and the lower the moisture level, the more rapid is the penetration rate.

2. A maximum allowable *penetration rate of chloride* in the new cover (or in the coating.) The higher the moisture level, the more rapid the penetration rate (provided chloride enters by pure diffusion. If it enters by convection caused by capillary suction, high moisture content might be positive). Also the chemical composition of the cover plays a big role.
3. The old concrete must not be susceptible to frost damage due to moisture accumulation caused by the new cover (or coating).
4. Cracking in the new cover, or coating, causing unacceptable moisture and chloride ingress to the old concrete, shall not be tolerated. Normally, this means that no through cracks bigger than 0.1 to 0.2 mm shall be tolerated. This requirement, in turn, can be translated to requirements for ductility, elasticity, thermal movements, moisture variations, and moisture movements, of the repair material, including the effect of natural ageing on these properties. The mechanical properties of the old concrete also play a role for the risk of cracking.
5. Total loss of bond between repair and old concrete shall not be tolerated, since cracks formed at the interface can accelerate moisture, chloride and carbon dioxide penetration into the old concrete. As for point 4., this requirement is related to mechanical properties of repair material and old concrete.
6. The new cover (and coating) shall be able to fulfil its protective function during the required service life. This means that it shall in itself have sufficiently high durability against all aggressive agents;
 - it shall be frost resistant in the actual environment.
 - it shall stand all potential chemical attack
 - it shall be sufficiently wear resistant
 - it shall not “age” in an unfavourable way (rapidly loose its protective ability)

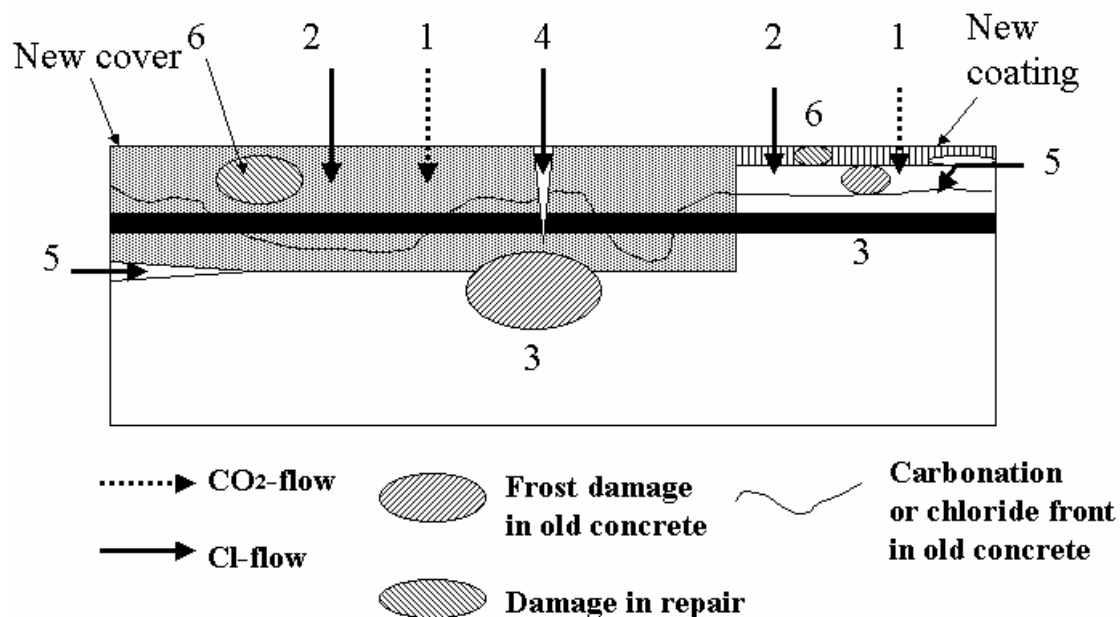

Figure 2.2: Requirements on a repair system; example. (For explanation, see text.)

2.4 Evaluation procedure - levels

Selection of a repair method is intimately coupled to the *cause, type, and extent of damage*. Thus, it is important to clarify these factors. After this has been done, it is possible to select relevant repair methods. Normally, there are only a few repair principles that are relevant. For each repair principle there are, however, often numerous *variants* in material composition and properties. There are also variations in how the work is executed when applying the repair system. The service life may also vary for different repair systems and materials of the same kind.

Once a repair method and material has been selected, they have to be evaluated with regard to service life in order to confirm that the repaired structure fulfils the service life requirement.

The evaluation of service life of a repair method/material applied to a given structure can be made on three different levels as illustrated in Figure 2.3.

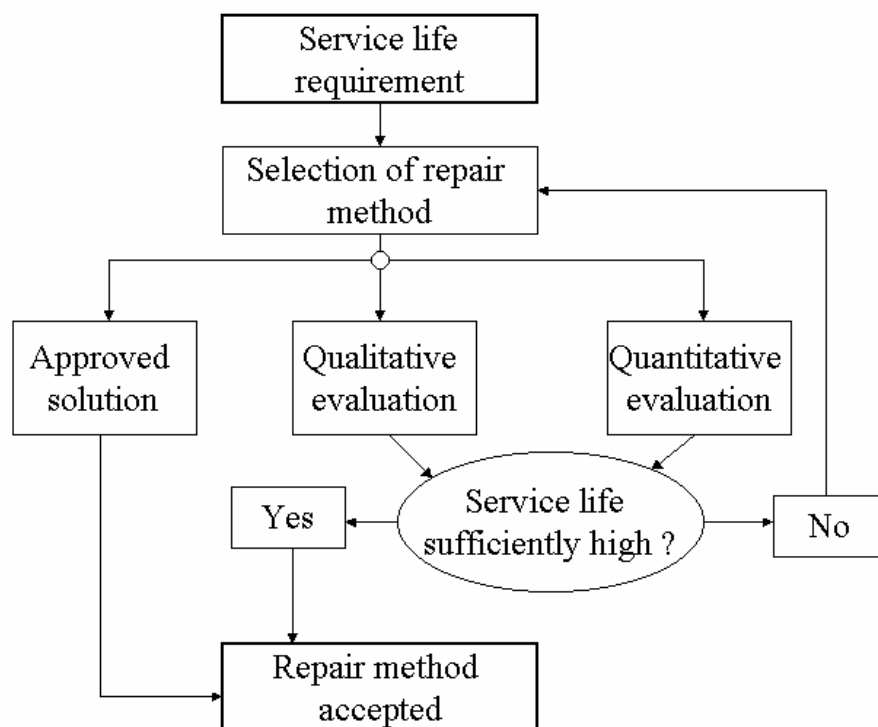

Figure 2.3: Different levels in evaluation of service life.

Evaluations on level 1 and 2 are almost always used today in connection with selection of repair materials, although they do not give quantified information on service life. Quantitative evaluation on level 3 is seldom used although fairly good possibilities exist today, at least for some frequent repair types, like repair of concrete damaged by reinforcement corrosion. A detailed example of a quantitative evaluation of repair of a structure damaged by corrosion is presented in *Appendix 4 to Annex 2*.

2.5 Evaluation on Level 1: Approved solutions

Approved solutions will often satisfy the service life requirement although the approach is very defensive, since it will conserve old technique. New repair materials and principles cannot be evaluated this way, and might therefore be effectively prevented from being used. Examples are new untried innovative processes for stopping reinforcement corrosion.

Besides, it might very well be that many traditional methods are not as good as anticipated, since their real function has not been followed-up. For example, it might be that a repair, that is supposed to stop further reinforcement corrosion for a long time, has not been effective, but this was not discovered, because no investigation of corrosion rate after repair was made. Another case is where a thick and highly impermeable polymer-based surface repair seemingly functions well, but in reality there has been substantial moisture accumulation in the old concrete, causing severe frost damage, that was not observed due to inadequate post repair investigations.

2.6 Evaluation on Level 2: Qualitative evaluation

Based on experience from previous repair, and on qualitative reasoning, the experienced engineer might in many cases estimate the durability of a given repair system. The engineer will not obtain a value of the service life in years, but might be able to distinguish one repair system and material from another, as regards their ability to fulfil the required service life.

Qualitative methods must be used for destruction types for which no quantified service life design models exist, such as different types of internal chemical attack and physical attack. They must also be used for evaluation of non-traditional repair methods for which the necessary data are missing.

Important input information in a qualitative evaluation is results from tests of the repair material itself, such as tests of frost resistance, chloride diffusivity and other transport properties, mechanical properties, chemical composition, etc. Reliable information from manufacturers and experts in durability can also be used in the evaluation.

Examples of qualitative evaluation

Example 1

An example of a qualitative evaluation is when different types of cement-based repair concrete, used as replacement for a frost damaged concrete cover over corroding reinforcement in a chloride environment, shall be evaluated. Then, without any calculations it is quite clear that the concrete with the highest salt-frost scaling resistance, demonstrated by a test, is superior to concrete with more inferior frost resistance. Furthermore, in cases where frost attack might be a problem, the concrete with the lowest water cement ratio ought to provide the best protection for the reinforcement. No quantitative calculations are needed to select the best material. On the other hand, this approach will not give a precise value for the service life, expressed in years, of the repaired structure.

Example 2

Another example is when one has decided that a polymer-based coating shall be applied as protection on a concrete surface. Then, the durability of the repair material in itself is fundamental. It is quite clear that the polymer with the highest anticipated (from experience) or measured alkali-resistance and UV-resistance, based either on experience or on test results, is most suitable, provided all relevant mechanical properties (strength, elasticity, ductility, wear resistance, etc.) seem acceptable.

Example 3

Also when a polymer coating shall be compared with a cement mortar as surface protection, a qualitative evaluation will normally show that the cement-based material is the best choice. The choice, however, will also depend on what mode of deterioration the surface layer will

have to protect against; e.g. further frost or erosion attack, or further reinforcement corrosion. In the first case the polymer might be the best choice, in the second the cement-based material might be the best. It will also be necessary to take account of other requirements associated with the execution of work in order to select the most appropriate repair method.

Example 4

Another case where cement has to be compared with polymers concerns the injection of cracks and holes. Principally, from a chemical point of view, cement is preferable, although this statement cannot be based on a service life calculation, but merely on qualitative reasoning. On the other hand, the feasibility of executing the work must also be considered, and, therefore, it is often necessary to select a polymer. The polymer with the highest alkali resistance, as demonstrated by testing or experience, should then be selected, provided its ability to penetrate the cracks is sufficiently high.

Example 5

Innovative procedures for reinforcement protection, or treatment of chloride infected concrete cover, such as different types of cathodic protection, chloride extraction, and re-alkalisation, cannot be based on practical experience, since there is almost no reliable long-term experience for most of these procedures. Further, there are no quantitative methods for calculating the effect of these new methods on service life. Therefore, the engineer has to rely upon his own common sense, and to the information provided by respected producers and contractors.

The same is the case with other new repair procedures like use of stainless steel reinforcement. According to manufacturers, and many researchers, cast-in stainless steel cannot corrode at normal chloride concentrations found in normal environment. Therefore, it might be a good material for repair, since it permits the use of low cover depths. This opinion has, however, been contradicted by other researchers, e.g. [4], who state that the positive effect of stainless steel depends on the composition of the steel, since some steels do not provide the increase in threshold chloride concentration needed for long service life at low concrete cover. In this case the engineer has to rely upon information from experts and his own judgement. There is, however, a good possibility of making a quantitative evaluation, provided reliable data for threshold chloride concentration can be obtained, either from the manufacturer, or from research.

Further examples of qualitative evaluation of different types of damage

In *Annex 1*, a qualitative evaluation repair principles and methods for concrete, damaged by different destruction mechanisms and types of damage, is presented.

2.7 Evaluation on Level 3: Quantitative evaluation – service life design

2.7.1 General principles of service life design

Evaluation on levels 1 and 2 give no quantitative information, expressed in years, on the service life of the repaired structure. During the last decade useful methods for service life calculations, “service life design”, have been developed for new structures. Examples of such service life design procedures are furnished in reports from the EU-project DURACRETE, [5]. Service life is normally treated as a *deterministic* property, having one single value determined by single values of all material properties and environmental properties used in the analysis. However, in DURACRETE service life might also be treated as a *stochastic property* having a certain mean value and a certain spread. Input in the calculations is

quantitative data (mean values and spread) in material properties (like effective diffusivity of gases water and ions, threshold concentrations for onset of destruction), and environmental properties (like moisture, temperature, salt concentration). All these data are used in theoretical destruction models.

The principles for a stochastic service life evaluation are shown in Figure 2.4.

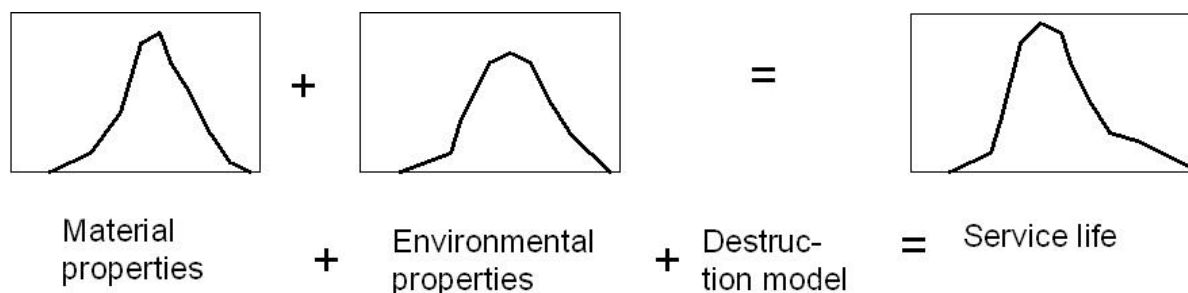

Figure 2.4: Principles (simplified) of a stochastic service life calculation with regard to a type of destruction governed by a diffusion process and a threshold concentration needed for start of destruction (e.g. reinforcement corrosion). The diagrams indicate frequency functions of different properties and service life.

Service life calculation methods based on the same theoretical basis have also been developed for assessment of the *residual service life* of existing structures. Examples of such methods are given in the EU-project CONTECVET, [1]. These methods can be modified also to consider variations in material and environmental properties.

The most advanced service life design methods have been developed for reinforcement corrosion, since this is a destruction mechanism largely governed by diffusion processes, for which the “time axis” can be quantified, at least in theory. For other destruction types, more embryonic methods exist. Examples are alkali-silica reaction, different types of frost attack (internal and external), and leaching of lime by percolating water, for which methods are described in [1b], [1c] and [1d].

The rate of many destruction types is increased if another destruction mechanism is operating simultaneously. Such “synergistic effects” must be considered. Examples of how to consider synergy are discussed in [6].

2.7.2 Application of quantitative evaluation of service life to repaired structures

For the repaired structure, the assessment of service life is more complex than for a new, or existing, structure, since the *interaction* between the old concrete and the repair must be considered. Such interaction might be of a *mechanical* nature and result in cracking and loss of bond. Other interactions are of *chemical* nature, where the moist alkaline sub-base concrete might adversely affect the repair material, e.g. a coating, or crack injection, based on polymers.

A fundamental interaction for service life is the *moisture* interaction between repair and old concrete. This interaction can be extremely negative, especially if the moisture content in the old concrete is increased as a result of repair. Frost damage might then appear, and chloride

ingress might be increased. If, on the other hand, the moisture content is reduced as a consequence of repair, the carbonation rate might be increased.

The service life assessment of a repaired structure is facilitated by the fact that much information on important material properties can be obtained by testing the old, damaged structure. Examples of such information are: amount of reinforcement corrosion, corrosion rate, carbonation depth (giving information on the carbonation rate), chloride profile, strength, erosion depth, etc.

A quantitative evaluation of the service life of a repaired structure requires the following information:

1. Knowledge of how to describe the *time process* of deterioration (the deterioration model) for all destruction processes involved
 - continued destruction of the old repaired structure
 - destruction of the repair material
 - destruction of the interface between old structure and repair material
 - possible synergistic effects
2. Quantified information on material properties of the repair material and *also on properties of the concrete to be repaired*. Important properties are:
 - transport coefficients of moisture (liquid and as vapour), gases and ions
 - binding isotherms of water, gases and ions
 - threshold concentrations of ions (primarily Cl)
 - aging properties (“durability”) of the repair material itself when exposed to the actual environment (like high alkalinity, UV-radiation, frost, chemical aggressors, etc.)
 - mechanical properties needed for calculating risks of loss of bond and cracking.

A quantitative evaluation, therefore, relies upon *test methods* that measure relevant properties in a relevant manner. Thus, all transport coefficients shall be determined as a function of the moisture content inside the material, and not be measured only at some arbitrarily chosen RH-level. Likewise, the threshold chloride concentration shall not be some average value supposed to be valid for all concrete, but be the value that is valid for the actual concrete type.

2.7.3 References to applications of quantitative evaluation of service life

Applications of quantitative service life evaluations of repaired structures are given in the following documents:

- *Annex 2. Main text*: Gives principles for assessing service life with regard to some frequent damage types. Furthermore, information needed for a service life assessment, and test methods for obtaining this information is given in tables.
- *Annex 2. Appendix 1, 2, 3*: Describes how the moisture level, the carbonation depth, and the chloride profile in the repaired structure are affected by repair.
- *Annex 2. Appendix 4*: Gives a detailed practical example of a quantitative service life assessment.

3 EVALUATION WITH REGARD TO STRUCTURAL STABILITY AND SAFETY

Additional information is given in *Annex 3*.

3.1 Structural stability before repair

A vital part in the assessment of an existing, damaged structure is the analysis of its present structural stability and safety. Methods for this have been described in the EU-project CONTECVET [1], for the three damage mechanisms, reinforcement corrosion [1a], alkali silica reaction (ASR) [1b], and frost attack [1c]. Information is also given on how to assess the status of concrete damaged by leaching, [1d].

Basic input information in this assessment is residual strength of concrete, residual bond strength between concrete and reinforcement (estimated from measurements of tensile strength), E-modulus of concrete, depth of surface scaling, loss of cross-section of reinforcement, information on geometry of the structure (dimensions, cover). Other information might also be needed.

On the basis of the structural analysis it is decided whether the structure should be left without repair for some additional years, or if shall be repaired, or if it shall be removed or replaced.

Note: The decision whether repair shall be made or not will also depend on other things than the result of a structural analysis, although this is often of critical importance. For a structure that is acceptable from a structural point of view repair may be justified in order to reduce the ongoing rate of destruction, increase life, reduce future maintenance cost, or improve appearance

If the decision is to repair one has to decide which technique to use. Often some strengthening has to be done in order to secure the required structural stability. Then, all data determined in the assessment of the damaged structure are also required in the analysis of the stability of the repaired structure.

3.2 Design of the repaired structure with regard to structural stability

The required structural stability and safety of structures are regulated by valid official codes. In many cases, society also prescribes the load the structure shall be able to carry with prescribed safety. *All these official rules have to be followed in the analysis of the repaired structure.*

The owner might have additional requirements on safety and load to be obeyed. So for instance, it might be that the structure shall be upgraded to higher load capacity after repair.

Once a repair procedure has been decided, a structural analysis of the selected procedure should be made in order to verify that the structure fulfils the requirements after repair. This analysis is *equivalent to an ordinary structural design of a structure to be built*. In the repair case more information on material properties and dimensions are at hand. Therefore, it might be possible to *reduce partial safety coefficients on material*. This possibility should be considered since it might have significant positive economical consequence.

Input in the structural analysis is:

1. Data from the previous assessment of the damaged structure; see paragraph 3.1. *It is very important that the designer decides which data from the old structure are needed, and from what places in the structure these data shall be obtained.* Many times, there are only a few parts in the structure for which structural stability is crucial. Most data should be taken from these parts, and not from parts that do not significantly influence structural stability.
2. Data for the repair material; mainly, strength and deformation properties. *The required values of these have to be decided by the designer.* The real properties have to be verified by testing, or be guaranteed by the producer of the repair material.
3. *Required data for bond* between old concrete and the repair material.

The structural analysis can often be made using the same procedures as for the design of new structures. There are differences, however. One possibility, mentioned above, is a reduction of partial safety coefficients. Other important differences are:

1. Mechanical properties of the old concrete and the repair material are not the same. This will influence the stress distribution between the materials at loading. The repaired structure is a sort of *composite structure* and should be treated as such in the analysis.
2. The old structure is already exposed to stresses when repair is made, while the repair is unstressed. This will affect the effectiveness of the repair. This effect is especially marked for pre-stressed structures repaired by unstressed concrete. The design of the repair should be made in such a way that these differential stresses are taken into account.
3. The old concrete has almost no creep deformation left, and small moisture movements. The new repair material might have substantial creep and high early shrinkage. Therefore, stresses might arise at the interface that might lead to bond failure. This risk has to be considered. The risk will be diminished if a repair material is selected that has small long-term deformations. The maximum values of these, used in the calculations, should be stated by the designer, and used for the design of the repair material.
4. When a new concrete “encasement” is cast around an old structure that is relatively cold, big tensile stresses due to early temperature rise in the encasement can easily occur. The effect might be thermal cracking in the encasement and loss of bond. The risk of thermal cracking should always be analyzed by the designer. Maximum values of temperature rise in the repair concrete should be stated. The repair procedure has to be made in such a way that this fixed maximum temperature is not transgressed (e.g. by pre-cooling the repair material).

It is important that the designer of the repair prescribes what tests should be made on the repair material, and on the repaired structure; tests of bond strength, tests of mechanical strength of repair, etc.

If it turns out by the structural analysis described above, that the requirements for load-carrying capacity and safety cannot be met with the repair system selected, new repair systems have to be selected and evaluated in the same way until an acceptable system is found.

The structural evaluation does not have to consider execution of work (besides the risk of thermal cracking described above). Nevertheless, it has to be understood in the structural evaluation that it is possible to perform the repair that is evaluated. Therefore, repair systems that are difficult to execute in a safe way need not be evaluated.

Evaluation of execution of work of different types of repair is described in paragraph 4.

3.3 Long-term structural stability – service life

Design of the repaired structure as described in paragraph 3.2 gives the structural stability directly after repair. If no destructive action occurs in the future, the design is also valid for a long time after repair. Such “steady state” behavior is normally assumed at design of new structures, since then, no “time axis” after 28 days is considered. Required durability is instead secured by selecting material properties that are known to yield long service life.

In the repair situation, one might always assume that continued deterioration in the old structure will occur after repair, although at a reduced rate. However, in the structural design of the repaired structure the structural engineer need not consider future changes in structural stability, but base the analysis on the assumption that repair systems and materials with long service life have been selected. As previously stated, this is also the assumption made for the design of a new structure.

In order to facilitate the analysis of service life of the selected repair system and material, the designer shall, however, furnish *information on minimum acceptable data* for material strength, material stiffness and bond strength. Such data are also important in conjunction with supervision of the structure, since it gives the basis for decisions concerning whether renewed repair is required.

3.4 Repair methods of interest for structural analysis - Examples

Repair methods of interest for analysis of structural stability are such that require a mechanical/structural interaction between old concrete and repair material. Such methods are:

1. Removal of old concrete and replacement by new concrete with adhesion to the old rinsed concrete surface; with or without addition of new reinforcement, with or without fibres in the new concrete. The repair might be a surface repair, or a repair of more extensive damage reaching below the reinforcement level.
Damage when this method is used has often been caused by reinforcement corrosion, or by some type of erosive surface attack (frost or acids).
2. Additional concrete cover (reinforced or non-reinforced, with or without fibre) on old concrete without taking any of this away.
The damage when this method is used might be caused by reinforcement corrosion that has not yet led to spalling or cracking of the cover.

3. Same as point 1., or 2., but polymer concrete is used instead of cement based concrete.
4. Strengthening by application of fibre composites, steel plates or other strong materials glued to the surface.
This method might be used when damage has weakened the strength of concrete, or when the structure is intended to take more load than before repair.
5. Repair of deep damage in the interior part of the old structure.
Damage when this method is used has often been caused by some sort of expansive internal attack (ASR, frost, sulphate). Normally deep injection is used. In other cases the structure is strengthened by outer means (like concrete “corset”, or steel “corset”).

Also the Swedish “Öland Bridge” type of repair might be considered, i.e. when a new structure is cast outside the old, without significant mechanical interaction between the two structures directly after repair, but with gradually growing interaction as the inner structure gradually decays.

There are several examples in [7] of repair options that can be used for structural repair.

3.5 Example: Repair of beams

The principles of performing a structural analysis of the repaired structure are the same irrespective of the type of element. The principles are exemplified by the simple case, repair of beams, figure 3.1.

As can be observed in the figure, beams to be repaired can be divided in three groups. Group 1 includes ordinary beams without pre-stressed or post-stressed reinforcement. Input in the structural analysis is an overall and generic description of how these types of beams can be repaired. The factors that should be taken into account in the structural analysis must be defined. As an example, consider a beam which is going to be repaired on the tension side due to damage caused by corrosion, or some type of erosion. A suitable, and much used, repair technique is to remove the cover to a depth where there is no damage and a low chloride level. Additional reinforcement bars will be placed, and a new cover will be cast.

As shown by Figure 3.1, there are four main options with regard to requirement on strength, and final geometry of the member. These options are the same for all beam types.

Example; beam repair, option 1:

In this case the goal of the repair is; (i) to achieve the same load capacity and serviceability as was initially required when the structure was built, (ii) to maintain the same geometrical form as it had initially.

Example; beam repair, option 4:

In this case the goal of the repair is, (i) to increase the load-carrying capacity and/or increase the safety of the structure, (ii) to allow changes in the initial beam geometry.

The quality of the repair material to be used (strength, stiffness) and the thickness of this depends on the load situation (location of damage, required strength of repaired structure), but also on properties of the old structure to be repaired (strength, amount of non-corroded reinforcement, dimensions, cover thickness, etc.). The aim of the structural analysis is, (i) to

evaluate the most rational repair technique from a structural point of view, (ii) to define quality requirements on the materials and systems to be used for repair, (iii) to define the minimum acceptable levels of bond and other properties of importance for structural stability directly after repair and during the service life of the repaired structure.

The location of damage must be considered in the design, e.g. anchorage zone, tension zone, compression zone, shear zone. Different repair techniques are often needed for different location.

As stated in paragraph 3.2, the design is made according to traditional methods used for design of new structures. The main difference is that it might also be necessary to consider stress distribution between the old and new concrete, and its effect on deformation and strength. Another difference is that partial safety factors on concrete in the old structure might be reduced, because more reliable information than for a structure yet to be built, can be obtained by testing the old structure.

Practical evaluation methods for beams, but also for other structural members (slabs, columns, panels), are described in *Annex 3*.

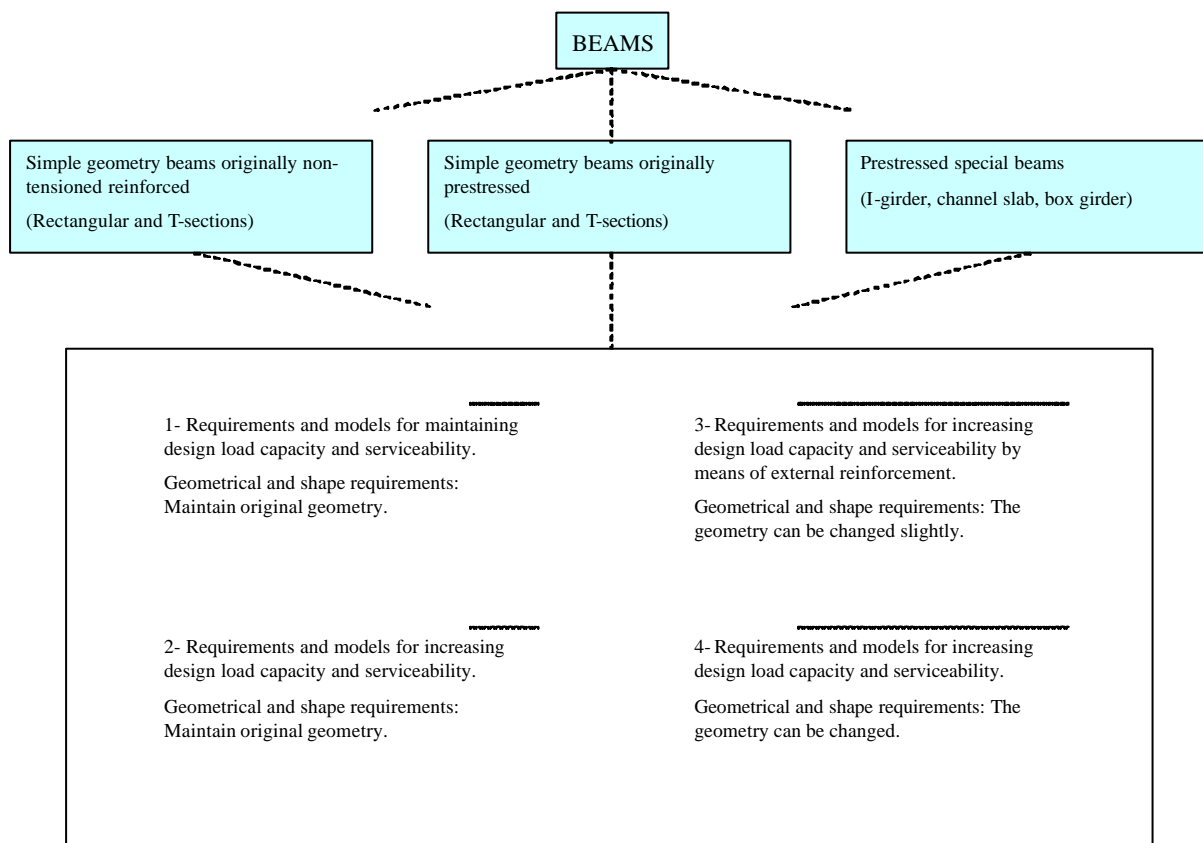

Figure 3.1: repair of beams. Different types of beams. Different requirements of the repaired beam.

4 EVALUATION WITH REGARD TO EXECUTION OF WORK

Additional information is given in *Annex 4*.

4.1 Introduction

Different frequently used *general procedures* used in repair are described and analyzed in this document. Frequent procedures and effects of these are:

- (i) Methods of removing the damaged concrete from the old structure, and their effect on the surface quality and bond to the repair material.
- (ii) Methods of injecting cracks and porous concrete, and their effect on the permeability and strength of the “old concrete”.
- (iii) Methods of placing the repair material on the old structure, and their effect on bond and other properties of importance for the behavior of the repaired concrete.
- (iv) Methods of characterization of the surface quality after removal of the damaged concrete.
- (v) Need of different types of formwork.

Other factors to consider in an evaluation are:

- (i) Safety of workers and public.
- (ii) Rapidity of different repair options.
- (iii) Impact on environment.
- (iv) Disturbance to function of the structure or to the surroundings during repair.

Many of the procedures used in repair will be the same regardless of the type and the cause of damage. For instance the methods for removal of a damaged reinforcement cover are the same for all damage causes that have led to deterioration of the outer part of the concrete. The decisive factors concerning removal of damaged concrete are the depth, location of damage on the structure, environmental conditions, requirements regarding physical and mechanical properties of remaining concrete, etc.

Therefore, the evaluation of execution can normally be carried out regardless of the type and cause of damage. Only the *type of repair* depends on the type and cause of damage, but normally not procedures used in *execution of repair*. There are exceptions, however, where the execution is directly related to one single damage cause, like cleaning of corroded reinforcement or application of corrosion inhibitors.

Certainly, all decisive factors needed for choice of repair method have to be determined and established before the execution. For instance, the thickness of the concrete layer, which has to be removed, has to be determined before the start of the execution of repair work.

4.2 Topics of repair action

Figure 4.1 shows 12 topics, or “elements”, involved in repair work. The topics are not given in any particular order. Some can be part of a repair method, while some may also serve as complete repair methods. The execution of any topic given in Figure 4.1 is independent of the type and the cause of damage. This will be shown by two examples.

Example 1; Figure 4.1:

Consider the case where the reinforcement cover is damaged by *chloride initiated corrosion*. It has been decided that the following 4 or 6 topics shall be involved:

1. The concrete should be removed to a certain depth below the surface of remaining concrete.
2. The new concrete surface shall be cleaned from dust and other pollution.
3. The reinforcement should be cleaned from chloride and other pollution.
4. A new concrete cover should be cast (and cured properly) in order to protect the reinforcement, and to restore structural stability.
5. The repair method may also include application of “corrosion inhibitors”.
6. For aesthetical reasons a protective non-reinforcing surface layer on the cover, like polymer-based paint, will be used.

All these topics/elements are shown in Figure 4.1, Example 1.

Another case is when the concrete cover has been damaged by some type of physical attack, for instance *salt-frost attack*. Even in this case, the depth of the concrete, that has to be removed, must be determined before repair work starts. Exactly the same topics in repair as were involved in Example 1 (except the use of inhibitors) can be used in order to repair the structure.

Example 2; Figure 4.1:

Consider the same case as Example 1. In places where active corrosion is going on the chloride contaminated concrete has to be removed, and the same procedure as in Example 1 has to be used and be evaluated. In other parts, corrosion has not yet started, because the threshold concentration has not reached the bars. Surface cracks exist, however, in these parts. In order to stop (retard) ingress of chloride it is decided to remove chloride infected concrete from these parts, and besides to use crack injection of some type (cement-based or polymer-based). Therefore, also execution of injection has to be evaluated. This additional step is shown in Example 2 in Figure 4.1.

4.3 Evaluation of topics of repair action - principles

Each topic/element in a repair can be performed in different ways, and by different methods and materials. Examples are shown in Figures 4.2 and 4.3. All these options should be evaluated.

Topics of repair actions

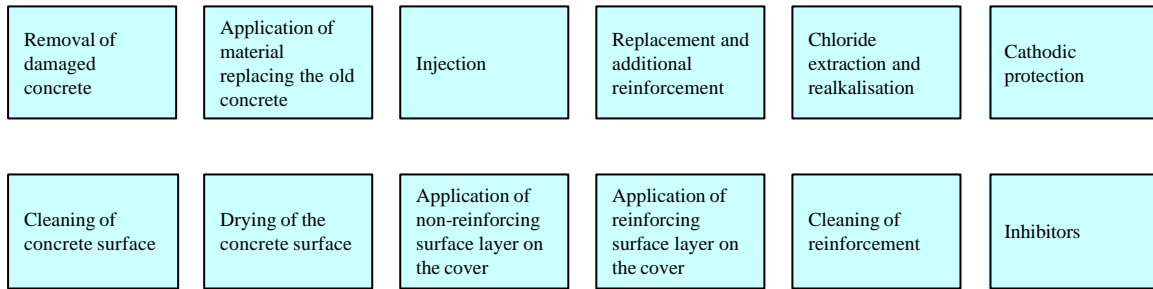

Example 1: Chloride initiated corrosion

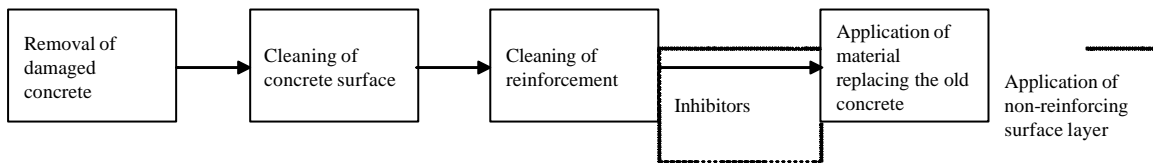

Example 2: Chloride initiated corrosion. Cracking

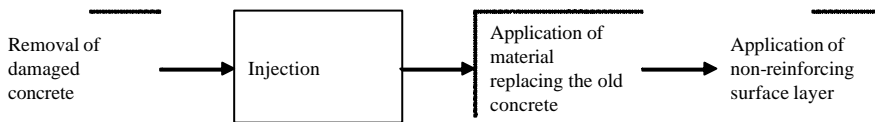

Figure 4.1: Topics of repair actions and examples of repair methods including some of the actions.

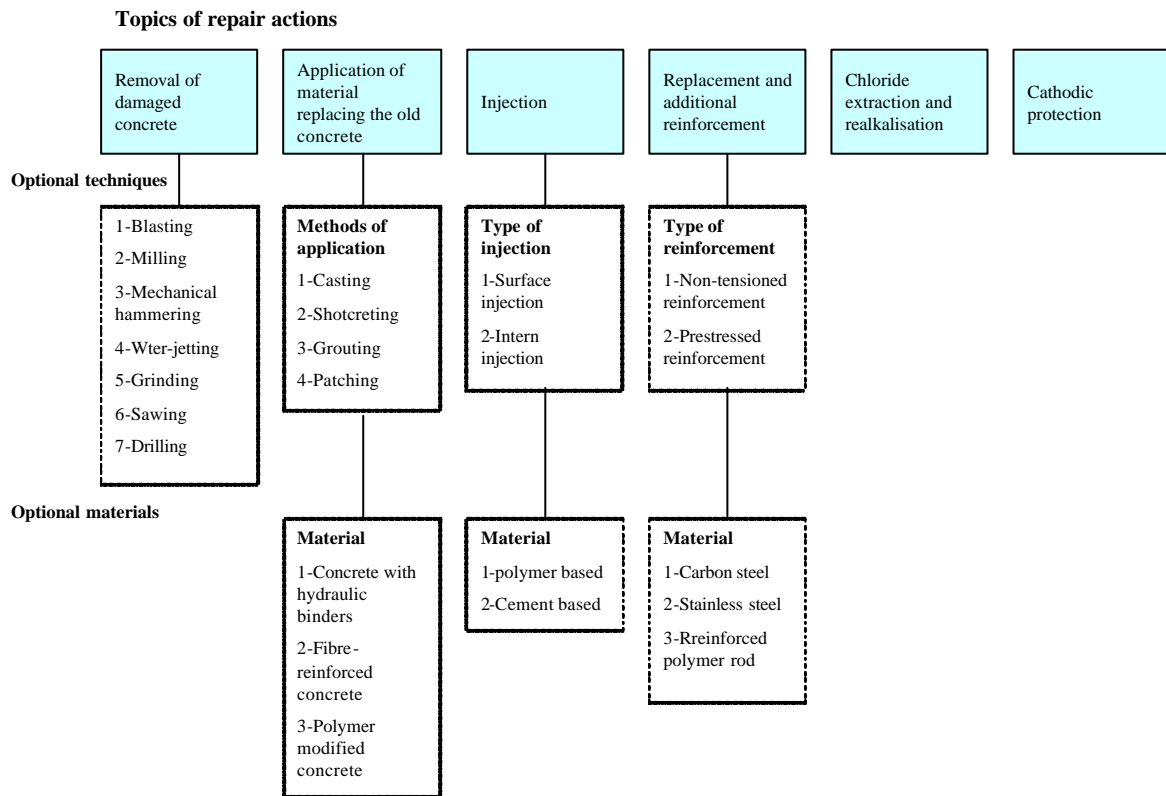

Figure 4.2: Methods to perform the repair actions, part 1.

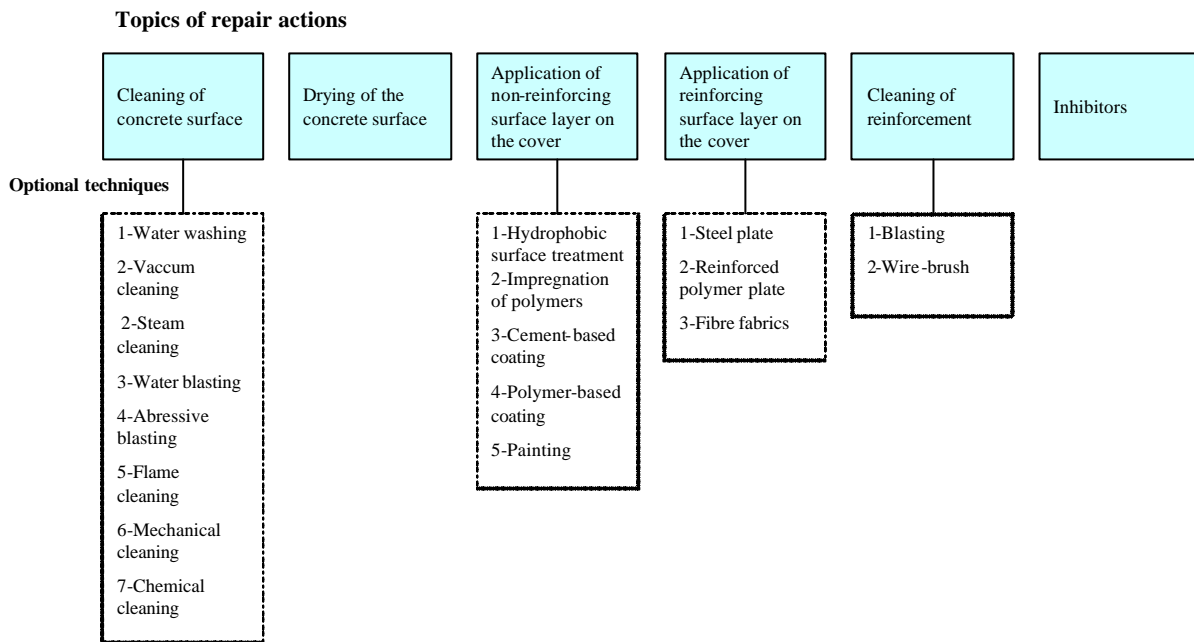

Figure 4.3: Methods to perform the repair actions, part 2.

4.4 Evaluation parameters

Each topic of repair action, and each optional technique within the action (Figure 4.1-4.3), should be evaluated with regard to the following aspects, called *evaluation parameters*:

- i. Working environment, i.e. creation of dust, noise, vibration, hazardous substances affecting the workers, and any other impact on workers caused by execution of repair work.
- ii. Effects of non-technical nature, such as disturbance of traffic, noise and other types of annoyance.
- iii. Effects of climatic conditions during repair work; effect of cold, hot, moist weather.
- iv. Simplicity or difficulties of applying the technique.
- v. Degree of applicability with regard to the type of structure and location on the structure.
- vi. Need of additional equipments, like forms and scaffolding
- vii. Speed of the operation and factors influencing that.
- viii. Influence of the action/method on the physical and mechanical properties of the remaining and new parts of the structure.

4.5 Evaluation of execution of work - example

In Table 4.1 an example of evaluation of techniques used in the topic “removal of damaged concrete” is presented. The table (somewhat revised) is taken from a Swedish book on concrete repair, [8].

Table 4.1: Example of evaluation of the repair action removal of damaged concrete, [9].

Method	Working environment	Non-technical issues	Climatic conditions	Application Simplicities/difficulties	Applicability with regard to type of structure	Need of additional equipment	Speed of operation	Influence on properties of the structure
Blasting	Creates dust and noise. If the surface is contaminated additional protection is required.	Applied to infrastructure construction the method may cause disturbance of traffic and create dust and noise.	No restrictions.	Suitable for removing thin concrete layers.	Applicable to all types of structures.	Scaffolding may be needed for vertical structures. Equipment for suction of dust and particles often needed.		Micro-crack free surface. Good bond properties. Takes away stain from reinforcement.
Milling	See blasting	See blasting	No restrictions.	Suitable for making grooves for additional reinforcement. Suitable for removing limited and thin concrete layers	See blasting Suitable for making grooves for additional reinforcement.	See blasting.		See blasting
Mechanical Hammering	See blasting. Also vibrations and noise	See above. Also heavy noise.	No restrictions.	Suitable for removing thick concrete layers. Applicable for making grooves for additional reinforcement.	See blasting.	See blasting.		Partly damages the remaining concrete. May damage the reinforcement.
Water-jetting	No dust, low noise and no vibration.	Minor disturbance. If the surface is contaminated the water should be taken care of.	Freezing risk at low temperature	See mechanical hammering.	See blasting. Should be used with care for indoor structures.	Scaffolding may be needed for vertical structures. Water must be taken care of in indoor work	Rapid method.	See blasting.
Grinding	See mechanical hammering.	See blasting.	No restrictions.	See blasting.		See blasting.		See blasting.

Sawing	See blasting.	See blasting.	No restrictions.	Suitable for removing parts of the structure/ structural members. Suitable for making grooves for reinforcement.	See blasting.	See blasting.		See blasting.
Drilling	See mechanical hammering.	See mechanical hammering.	No restrictions.	Suitable for making openings and grooves for reinforcement.	See blasting.	See blasting.		See blasting.

5 EVALUATION WITH REGARD TO ENVIRONMENT AND HEALTH

Additional information is given in *Annex 5*.

5.1. Introduction

In the evaluation process it is important that environment and health factors are considered in the whole concrete repair life cycle – from the production of repair material to demolition and waste disposal. In this paragraph it is described how such an evaluation can be done.

We have to face the fact that the experience of this type of evaluation is relatively limited and the technique is still under development within many types of industry and processes. It can also be stated that a lot of facts and figures are still missing, meaning that today it is not possible to make a complete evaluation resulting in figures for different environmental impact, like emissions into air and water, energy consumption etc. However, it can serve as a useful tool for comparing different repair methods from an environmental aspect. The evaluation process can also serve as a type of environment and health checklist for concrete repair methods.

Instead of starting with complicated and extended evaluation processes, with high risk of giving misleading results, it is therefore recommended to start with checklists and relatively simple comparisons of different repair methods.

Another important point in evaluation of environmental impact is the *lifetime* of the repair. The impact on environment and health has a very strong relation to the lifetime of the repair. When comparing different repair methods it has to be done on basis of the expected lifetime of the repair. In a comparison, “Method 1” could be evaluated as more environmentally friendly than “Method 2”, but if the lifetime for “Method 2” is expected to be double that of “Method 1”, the total effect could be more favourable than using “Method 1”.

The methods described here should, therefore, be used with “common sense”. It is recommended that initially a survey is carried out, to find the most important questions and risks connected to the evaluated repair process. Subsequently, these points could be further investigated and evaluated before a final decision can be made.

The methodology described in this chapter is a summary. For more details, see *Annex 5*.

5.2 Methodology for evaluation - principles

The most thorough method for evaluating the environmental effect would be an Environmental Impact Assessment (EIA), or a Life Cycle Analysis (LCA). Since EIA is site specific, and more of a process than a method, it cannot be applied in the evaluation of a repair method. However, some of the methods used when performing an EIA may be suitable. To carry out an entire LCA on concrete repair might be too data demanding, but the “cradle to grave” thinking should be applied, and parts of such evaluation methods could be suitable.

In an evaluation the main focus is often on the effect of the repair on ecology, but other factors, such as impact on workers during application (see paragraph 4), and effects on a third party should also be considered. The reason for this is that some repair methods can produce pollutants and noise, making them unsuitable for use in some environments, like residential areas. Indoor environment should also be considered. Even if most concrete repair is executed in outdoor environment, there may be some cases where the indoor environment should be

considered, e.g. at repair of floors. Thus the evaluation is made in three steps:

1. Evaluation of ecology (external environment)
2. Evaluation of indoor environment
3. Evaluation of health and safety

In the literature, methods and models have been suggested for environmental evaluation of new structures, examples are references [9] and [10], using the life cycle perspective.

These methods are used as a base, and with some adaptation, they can be applicable to the concrete repair process. In the repair process the choice is not as extensive as it is for a new structure. For example the materials, design and heating system are already chosen, meaning that many parameters influencing the total ecology of the structure are already fixed and cannot be changed. Thus, some parts of the evaluating systems for new structures can be excluded or at least simplified in the repair case. Thus, the evaluation described here includes the steps in Figure 5.1.

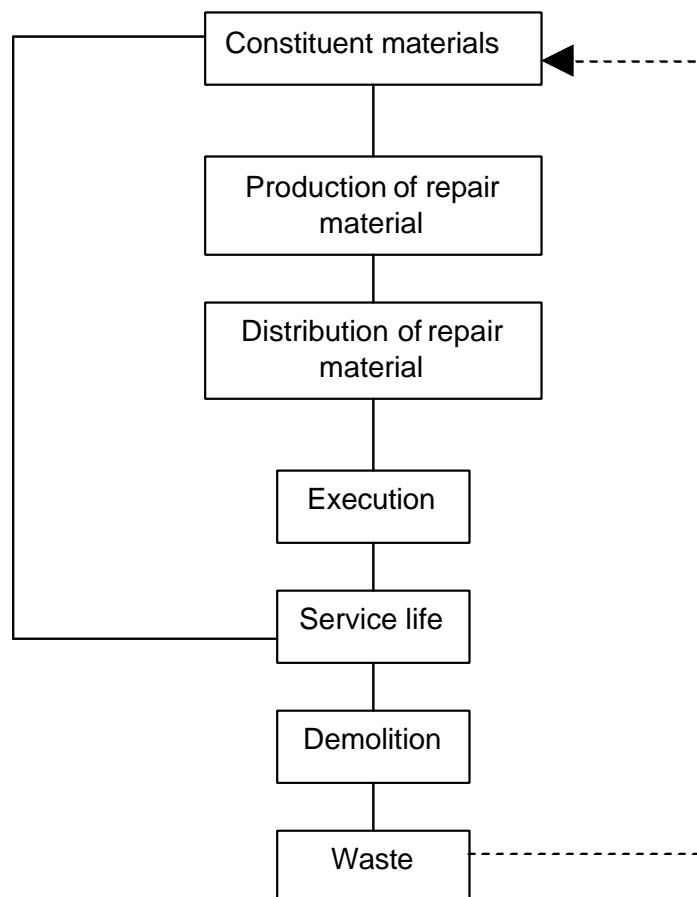

Figure 5.1: Life cycle steps in the ecology and health evaluation

Each step in the process is then evaluated with regard to a number of indicators referring to ecology, indoor environment and health and safety.

5.3 Evaluation of concrete repair with regard to ecology

A number of indicators are chosen for evaluation, or calculation, of the environmental effect during the concrete repair life cycle. For the ecological evaluation the effects to be considered are

- Consumption of non-renewable raw materials
- Consumption of non-renewable energy
- Emissions to air including CO₂, CO, SO₂, NO_x, dust
- Emissions to soil and water
- Effect on ground

Table 5.1: Summary table for External Environment Parameters considered in the ecology evaluation of a repair method or activity

No.	LIFE CYCLE PHASE	Type of energy	Raw materials	Emission to water	Emission to air	Effect on ground
		A	B	C	D	E
1.	CONSTITUENT MATERIALS					
1.1	- Raw materials					
1.2	- Recovered material					
1.3	- Origin of raw material					
2.	PRODUCTION OF RAW MATERIAL					
2.1	-Production process					
3.	DISTRIBUTION OF FINISHED PRODUCT					
3.1	-Production area / country					
3.2	-Transport method					
3.3	-Distribution type					
3.4	-Packaging					
4.	EXECUTION PHASE					
4.1	-Repair execution					
4.2	-Product adaption					
5.	USAGE PHASE					
5.1	-Operation					
5.2	-Maintenance					
5.3	-Service life					
6.	DEMOLITION					
6.1	-Dismantling					
7.	WASTE PRODUCTS					
7.1	-Reuse					
7.2	-Recycling					
7.3	-Energy production					
7.4	-Tipping					
7.5	-Dangerous waste material					

More detailed information on life cycle phases and environmental parameters is given in *Annex 5*.

It can be stated again that a lot of information needed is still missing. Therefore, one has to accept that some part of the table will remain empty. However it's often useful to make an approximate assumption making it possible to compare two or more repair methods with each other.

In the Swedish Building Products Declarations, [10], the manufacturer/supplier should declare substances in a building material with certain limits. These limits can of course vary between countries.

A specific repair material in the repair process is declared in one declaration. Thus, the total impact on ecology of materials in a repair process is the combination of several declarations.

The target is that the input data should be expressed in quantitative terms, although until more data are available qualitative data has to be accepted.

There are today several ongoing projects dealing with collecting and processing of available data so that it can be used as input to life cycle assessments, and other ecology evaluation processes.

As an example a LCI/LCA project run by the Cement Industry could be mentioned. One outcome from this project has been an environmental computer programme called “EcoConcrete” for providing LCA information on concrete structures. Access to the EcoConcrete program is limited to people who have passed a special training course.

Another project called “Eco-Service is sponsored by EC under Framework program 5 and covers research on the construction industry in relation to environmental sustainability. Within the project is an objective to create a baseline for the environmental impact from the production and use of concrete products in a life cycle. It is noted that information is needed in the areas of “Assessment of the impact from chemical additives” and “Possible leaching of harmful substances from concrete with residual products”.

Repair products to be placed in contact with drinking water need to meet specific requirements. There is a project running within the organization of European Commission (CEN/TC 104) with the goal to outline these requirements. A draft positive list of approved constituents of products for contact with drinking water is at the moment discussed but not yet agreed.

When it comes to concrete admixtures, EFCA (European Federation of Concrete Admixtures Association), have published an Eco-profile for plasticizers and superplasticizers, [11], [12]. The Eco-profiles include quantitative data for raw materials, emissions to air, emissions to water, solid waste and total energy per kg admixture. These eco-profiles are derived from primary data supplied by EFCA and its member organizations and verified by an independent consultancy from The Netherlands.

Information for data and the assessment procedure on dangerous chemicals are published by the European Chemicals Bureau (ECB), [13].

5.4 Evaluation of concrete repair with regard to indoor environment

Many people are reporting health problems related to the indoor environment. The symptoms are often asthma and allergies. There is great uncertainty today about what is causing the symptoms, and research is going on to try to find the relationship between ill health and the choice of building material, design and construction method. These relations seem to be very complex. The information we have today indicate that the determining factor for the quality of the structure is how the materials have been built in to the structure rather than the individual properties of a specific material.

When choosing material for repair, a material without emissions of any harmful or irritating substances into the indoor atmosphere should be used. The material must also have good resistance to the various stresses to which they are exposed – not least moisture. This is of course valid for materials in new as well as in repaired structures.

As the processes leading to health problems caused by indoor environment are still not fully understood, this paragraph should be considered as a summary of factors to be taken into consideration by the various members involved in the concrete repair process.

Even in the case of indoor environment there is a shortage of facts and data meaning that the evaluation process should be seen more as a checklist than a complete evaluation tool. It can also be used as a tool for comparing the impact of different repair methods or repair materials on the indoor environment. This evaluation of indoor environment is only relevant when the repair activity takes place in an indoor structure. In the case of an outdoor structure this part of an evaluation can be left out.

Table 5.2: Summary table for indoor environment

8.1	Harmful substances	
8.2	Self emissions	
8.3	The repair process	
8.4	Surrounding materials	
8.5	Basic data for recommended conditions for surrounding material	
8.6	Operation and maintenance	
8.7	Sound level	
8.8	Electric and magnetic fields	

More information on indoor environmental parameters is given in *Annex 5*.

5.5 Evaluation of concrete repair – health and safety during execution of work

Questions related to health and safety for the workers during handling of the repair materials are regulated in the legislation. The work on classification and labelling of chemical products is done on an international basis. This work has a high priority in Europe and the legislation within EC became common since about two years ago.

Manufacturers, importers and others, who place a product on the market for professional use, shall provide information on the properties of the product from the viewpoints of risk and safety.

Safety data sheets need not be provided when products are marketed, sold or supplied in consumer packaging in retail trade to the general public. Safety data sheets for such products shall on the other hand be made available if requested by a professional user.

All marketed substances and preparations placed on the European market must be classified and labelled in accordance with Directive 67/548/EEC (substances) and 1999/45/EC (preparations). The evaluation results in classification of the chemical product concerning physical-chemical properties, health and environmental effects. The information is communicated on the label and in the 16-point Safety Data Sheet (91/155/EC). Therefore Classification and Labelling is a useful tool for risk management of chemical products.

For evaluating the health and safety parts, data given in the 16-point Safety Data Sheet (point 1, 2, 3, 10, 11 and 15) can be used.

1. Identification of the substance/preparation and company
2. Composition/information on ingredients
3. Hazards identification
10. Stability and reactivity
11. Toxicological information
15. Regulatory information

The above-mentioned points contain the most important information for the evaluation of health and safety risks during the execution phase. This is essential information in the evaluation process at a state where two or more concrete repair methods are compared before the final choice is made. Other information in the Safety Data Sheet deals with protective measures and recommendations for handling. Of course this information is very important later in the process, for all people involved in the handling of the product.

In point 12 in the Safety Data Sheet ecological information is given. As this information is treated in a separate evaluation it is not treated here.

The above-mentioned paragraphs are taken from the EC Directive 91/155/EC valid December 2003. It's always necessary to check the latest published Directive for the evaluation process.

More detailed information on the above mentioned paragraphs is given in *Annex 5*.

5.6 Example of an evaluation

The repair to be studied and exemplified is: *Patch Repair*.

Damage: Deteriorated outer part of concrete.

Method: Removing of damaged concrete and application of new repair mortar using cement based mortar mixed at jobsite. In this case the indoor environment of the structure will not be effected meaning that only external environment and health and safety are evaluated.

5.6.1 Evaluation of the concrete repair mortar with regard to ecology:

Name of product: "Polymer modified cement based repair mortar"

Name of Manufacturer/Supplier: "Supplier"

Environmental policy/Certification/Registration: Yes/ISO 14000/No....

Product information:

Product: Cement based one component repair mortar in powder

Constituent material in structure: 100% concrete

Safety data sheet: Yes

Classification: Xi (irritating)

No.	LIFE CYCLE PHASE	Type of energy	Raw materials	Emission to water	Emission to air	Effect on ground
		A	B	C	D	E
1.	CONSTITUENT MATERIALS					
1.1	- Raw materials					
	Standard Portland cement	Fossil and electricity	Limestone and sand		CO ₂ , NO _x , SO ₂	Limestone open-cast mine
	Aggregate, "crossed" and natural	Electricity and fuel for transport	Rock, nature			Open-cast mining", gravel pit
	Admixtures					
	Acrylic polymer					
1.2	- Recovered material	Energy in cement production				
1.3	- Origin of raw material	Europe				
2.	PRODUCTION OF RAW MATERIAL					
2.1	-Production process	Electricity				
3.	DISTRIBUTION OF FINISHED PRODUCT					
3.1	-Production area / country	Sweden				
3.2	-Transport method	Truck				
3.3	-Distribution type	Truck				
3.4	-Packaging	Paper bag				
4.	EXECUTION PHASE					
4.1	-Repair execution	The mortar is usually mixed with electrical hand mixer and handapplied at jobsite.				
4.2	-Product adaption	Small quantities are mixed during proceeding of work. No mixed mortar left.				
5.	USAGE PHASE					
5.1	-Operation	Does not effect operation of structure				
5.2	-Maintenance	No need				
5.3	-Service life	Depends on environment, specific structure etc.				
6.	DEMOLITION					
6.1	-Dismantling	Normally no specific need.				
7.	WASTE PRODUCTS					
7.1	-Reuse	n.a.				
7.2	-Recycling	Yes, both material and packaging				
7.3	-Energy production	Packaging: yes, material: no				
7.4	-Tipping	Inert material: no restrictions				
7.5	-Dangerous waste material	No				

5.6.2 Evaluation of the concrete repair mortar with regard to health and safety:

1. Identification of the product and of the company:

Product name: "Polymer modified cement based repair mortar"

Manufacturer/Supplier: "Supplier"

2. Composition/information on ingredients/classification of substances

Cement: 25-50%, Xi (irritating), R-phrase 41, 37/38. Contains chromium (VI). May produce an allergic reaction.

3. Hazards identification

Xi Irritant

Information on hazards to man and to the environment:

37/38 Irritating to respiratory system and skin

41 Risk of serious damage to eyes

Contains chromium (VI). May produce an allergic reaction.

10. Stability and reactivity

Materials to avoid/dangerous reactions.

Hazardous reactions possible with: Acids

Thermal decomposition and hazardous decomposition products: No decomposition if used as prescribed.

11. Toxicological information

Sensitization: sensitive persons can observe allergic reactions.

Experience on humans:

When skin contact: May cause irritation.

When eyes contact: Irritation

When inhalation: Irritation

When swallowed: Small amounts may cause considerable health disorders.

15. Regulatory information

Labeling according to EEC Directive:

The product is classified and labeled in accordance with EC directives/the relevant national laws.

Danger symbols: Xi Irritant

R phrases:

37/38 Irritating to respiratory system and skin

41 Risk of serious damage to eyes

Contains chromium (VI). May produce an allergic reaction.

S phrases:

26 In case of contact with eyes, rinse immediately with plenty of water and seek medical advice

39 Wear eye/face protections

6 EVALUATION WITH REGARD TO ECONOMY

An application example is given in *Annex 6*.

6.1 Introduction

Economical evaluation is an important part of an asset management system, and is used for different purposes. Two essentially different purposes are, (i) to fit the annual repair and maintenance costs within a certain budget, (ii) to predict the cost of a certain repair and remedial action to be applied on a certain structure or structural member.

Annual repair and maintenance cost

This type of evaluation is normally conducted for a large number of functionally similar objects within an asset portfolio. The object can be a structure, for instance a bridge, or a certain part of a structure, for instance deck or side beam of a bridge.

A very important input for such an evaluation is the degradation function which relates the age of the structure, or the structural member, to a certain degradation level or class. Another important input is the cost to upgrade a structure from a level/class of degradation to a required level/class of “functionality” or “quality”. The required level/class of functionality may be defined as a condition which, besides the usual maintenance measures, does not require any repair or remedial measures during a prescribed period of time. The functionality and quality can be described in different ways. They may be related to the structural safety or load bearing capacity, etc, see paragraph 3.

For stocks consisting of a large number of structures the functions can be determined by means of experience and statistics. The functions are not directly based on a certain damage mechanism or damage type, but they only express the general condition of the stock. However, in some cases an underlying damage mechanism may be pointed out. For instance, the causes of deterioration for many edge beams subjected to de-icing salts are chloride initiated corrosion and salt-frost damage. Hence in this case the degradation function is related to the cause of damage.

Prediction of the cost of a certain repair and remedial action

This type of evaluation concerns with the cost of a certain repair or remedial action applied to a structure, or a structural member. The purpose of this evaluation is to compare the costs of different repair principles, main repair methods, or repair systems. The evaluation may be performed in different manners, and with different aims. The evaluation may only concern the partial or total costs of a repair and remedial action at the present time, i.e. at the time of execution, or it may also consider the total life-time costs of the action, i.e. “Life-Cycle-Cost (LCC)”.

This chapter deals only with the second type of the economical evaluation, i.e. “Prediction of the cost of a certain repair and remedial action”. A comprehensive description of both types of evaluation can be found in [19] and [8].

Repair and remedial actions prolong the service life of the structure, and can be considered as an investment. When a decision about an investment is made, many factors have to be considered. The investment analysis is one important part of the facts and figures to be considered in the decision, yet it is only one of many aspects. Other aspects are risks, environment, market shares, good-will etc. It is a hard task to provide an all-embracing tool

for an investment analysis, which at the same time can meet different owner's needs, and be applicable for different types of assets. This chapter provides only a method to compare different repair and remedial actions. This chapter does not provide a straight forward calculation routine, which can lead to selection of the most profitable repair system. The method presented here should rather be regarded as a way to highlight the issues of importance.

The method of investment analysis will be presented within a LCC context because in this way it is possible to account for costs caused by failure, environment tolls, demolition, risks, etc. However, it should be noted that some of the decisive events/factors in an economical evaluation happen in a remote future, and the future is not easy to predict at least when the economical development is concerned.

6.2 LCC and its components

In the life cycle calculations (LCC), the investment is looked at from cradle to grave. When using this method it is important to look at the investment from an economical and a technical point of view, so all costs will be found and evaluated. The calculation is much more detailed than an ordinary investment calculation.

A LCC is often showed as an iceberg. The part that is visible, above the surface, is the direct investment cost, but underneath the surface are other sometimes even more important costs, which are called the operational costs. The operational costs must be part of the investment otherwise the investment will be incorrect. The costs depend certainly on the type of asset, how management is organized, which regulations exist, etc. In [19] and [8] different cost entries for bridges are presented. Below, some cost entries are generically presented.

The net total life cycle cost of a structure, C_{NT} , includes several costs and return entries, and can be expressed as follows:

$$C_{NT} = C_C + C_I + C_M + C_R + C_F + C_U + C_D + C_E + C_O - R_{RE} - R_{VI} - R_{RS} - R_U - R_O \quad (6.1)$$

Where C_C is the construction cost, C_I the inspection cost, C_M the maintenance cost, C_R the repair cost, C_F the failure cost, C_U the user cost, C_D the demolition cost, C_E the environmental toll cost and C_O the other costs, R_{RE} is the rental return, R_{VI} the value increase, R_{RS} the residual value, R_U the user return and R_O the other returns.

The equation may be extended to include other types of the cost and return entries, or be shortened to include fewer entries. Furthermore, all cost entries in the equation may consist of several subentries.

The content of such an equation depends on the purpose of the analysis, type of asset, and will certainly vary from owner to owner. Several entries in the equations are interrelated, which, if carelessly used, can lead to erroneous conclusions. Some examples are given below:

- High construction standards; if these can be equated to a high construction cost, it may decrease the need for maintenance, and may postpone the time of repair. These may reduce the stop time and the costs of user or, due to the higher rents and tolls, increase the cost of the user.

- A newly renovated building means increased value for the owner and a higher rent for the user.

The LCC analyses should be conducted cautiously, and the purpose of the analyses should be clear.

When two repair methods are compared, it is not necessary to include all type of costs, i.e. similar cost entries in the repair methods can be disregarded. Equation 6.1 can be reshaped in order to be used for estimation of repair costs. The elements included in the equation vary from case to case. Some elements are presented in paragraph 6.4 and 6.5, and in the application example presented in the *Annex 6*. Further elements can be found in [19] and [8].

6.3 Methodology

Mathematical tools

All entries in the equation 6.1 should be discounted to a reference time. Normally the present time is chosen as the reference time. The present time is normally the time that the investment is made.

The present value of the cost or the return entry i which will incur after j years, $x_{i,j}$, can be converted to the discounted value X_i , i.e. the value at the present time, by means of following equation:

$$X_i = \frac{x_{i,j}}{(1+r)^j} \quad (6.2)$$

$$r = \frac{1+r_{int}-1}{1+r_{inf}} \quad (6.3)$$

where r is the discount rate, r_{int} interest rate, r_{inf} inflation rate.

Equation 6.3 is one way of calculating the discount rate, [8] and [9]. The discount rate can also be expressed as the difference between the interest rate and inflation rate. However, the equation 6.3 is the theoretically correct way of expressing discount rate as a function of interest rate an inflation rate.

In practice the discount rate depends on many generally unspecified factors and there is no formula for its calculation. In general discount rates are significantly higher than the interest rate after inflation has been taken into account. This is primarily because the discount rate has to incorporate the risk of premature redundancy of the structure. The discount rate varies from country/company to country/company.

Application example 1

The cost of a repair action ($i = 1$), which will be conducted 8 years ($j = 8$) from now, is estimated €100000 ($x_{1,8} = 100000$), the interest rate is 5% ($r_{int} = 0.05$) and the inflation rate is 3% ($r_{inf} = 0.03$). The present value of the repair action (X_i) should be estimated.

The discount rate (r) is calculated by means equation 6.3, which gives $r = 0.02$. Then X_i is calculated by means of equation 6.2, which gives $X_i = 85349$. Now this cost is comparable with, and can be added to, the other costs occurring at the present time, or will occur in the future but are converted to the present time.

Any individual cost entries, C_X , in equation 6.1 consist of a number of sub-entries. For instance the repair cost C_X is sum of a number of sub-cost entries. The total cost is given by the following equation:

$$C_X = \sum_{i=1}^n C_{Xi} = \sum_{i=1}^n \frac{C_{ni,j}}{(1+r)^j} \quad (6.4)$$

Where C_{Xi} is the discounted value of the sub-cost entry number i , n is number of the sub-cost entries. It should be noted that for the sake of simplicity, all costs are presented as discounted values. A cost which occurs at the present time can be accounted for by using $j = 0$.

The costs, and the returns, are sometimes recurrent. If the events have constant period and payments, their discounted total value can be calculated by means of the following equation [9]:

$$Y_i = y_i \cdot \frac{1 - (1+r)^{-km}}{[(1+r)^m - 1]} \quad (6.5)$$

$$k = \text{trunc} \left(\frac{N-1}{m} \right)$$

where y_i is the amount of the periodical entry, for instance annual payments, Y_i is the discounted summation of all payments during the service life N . m is the length of the period, number of years between the payments, and k is the number of the periods during the service life N . Truncation (trunc) means that the lower integer of the calculated value is used.

Equation 6.5 is further illuminated in the *Addendum* at the end of this chapter.

Application example 2

Assume that the cost of the maintenance is €5000 every third years, service life of the structure is 30 years, and the discount rate is 2%. The total discount cost of the maintenance should be calculated.

$$k = \text{trunc} \left(\frac{30-1}{3} \right) = 9$$

$$Y_i = 5000 \cdot \frac{1 - (1+0.02)^{-9 \cdot 3}}{(1+0.02)^3 - 1} = 33830$$

An application example for different repair scenarios is provided in *Annex 6*.

Uncertain factors

Certainly most of the costs, which occur now or in the near future, can be estimated fairly well. However, factors the value of which must be estimated over a long period of time, are very uncertain, and may be decisive for the results of the economical evaluation. Three factors are very important, namely, the length of calculation period, the discount rate and the actual cost of the action in the future.

Assume that a newly developed repair system contains a component that cannot be dumped without paying a dumping toll. Some day the repair system will be removed and the toll should be paid. The total present cost of the component is the sum of the purchase cost, the cost of application, the discounted value of the removal cost, and the discounted dumping cost. The purchase and application costs occur at the present time, and are not difficult to determine. However, the two last costs can be rather uncertain to estimate. If the calculation period is long, and the discount rate is high, the present value of the component will be lower than the case where the calculation period is short and the discount rate is low. Furthermore, the longer the period, the more uncertain is estimation of the labour cost, dumping cost etc.

Example

Three repair options are being compared with each other. Assume that the structure, which will be repaired, should have 50 years service life after the repair. The first repair option (RO_1) includes a repair system which can protect the structure during 25 years, and should be repeated every 25 years. The second repair option (RO_2) includes a repair system which can protect the structure during the remaining 50 years of the service life of the structure. The third repair option (RO_3) is that the repair will be postponed for 5 years, and after 5 years repair will be made. During the 5 years, special inspection and maintenance measures will be taken, which increase the inspection and maintenance costs. These options are studied in the application example in *Annex 6*. Nevertheless, the results demonstrate that the discount rate has great influence on the outcome of the analysis. The difference between the total discounted costs is highly dependent on the discount rate.

6.4 Basic calculation factors

The information about basic calculation routines must come from the owner.

Service life and the economical life time

The calculation period is needed for determination of the total repair cost. The length of calculation period can be equated to the service life of the structure required by the owner. Such repair systems which have longer service life than required, and are able to extend the service life of the structure beyond the required service life, may induce a surplus value, which depends on the type and usage of the structure. The surplus value is only relevant if; 1) the structure continue in use after the end of the calculation period 2) the value of the rest materials exceeds the cost of dumping. However, it is the owner's decision whether to take into account the surplus value or not.

The calculation period for the repair systems which shorter service life than that required for the structure can be equated to the expected service life of the repair system. This may lead to several applications of the same repair system during the remaining service life of the structure.

The service life of a repair system may be determined by means of theoretical models, or by means of experiences from previous repairs. There is not much information about the service life of the repaired structures. However, some owners may have information about how repairs performed in their asset inventory.

Interest, discount and inflation rates

The discount rate or rate of return (often used in private sector) are not constant, and fluctuate. The rate varies between countries and between companies. The rates are normally decided by the owner.

Others

Other important factors are taxes and their effects on the results. Furthermore, it should be pointed out whether the repair is considered to be an investment or a traditional maintenance (depreciation).

6.5 Examples of repair costs

Initial costs

The information about the initial costs of repair, which should not be mixed by the initial investment when the structure was being built, comes from the contractor and the owner. The initial costs correspond to the investment costs, which include the planning of the repair by the owner, and a tender from the contractor. The initial cost may include the establishment of work site, scaffold, extra ordinary works in the periphery such as roads, fence, acoustic barriers and other environmental protecting measures, etc. Factors to be considered are as follow:

- Repair planning
- Location of the structure, type of environment, communications, etc
- Type of structure and structural element
- Type and extent of the damage
- The time available for the repair work
- Are there any monitoring devices to be installed

Stop costs

The information about stop costs comes from the owner.

The stop costs may include costs to the owner, to the user, or both. Traffic delays caused by bridge repairs may include costs to the user, for instance transportation companies, and to the owner, for instance decreased way tolls. Another example is the lost of income from the car parks and apartment houses.

The stops may also involve lost of market share and good-will.

Models to determinate stop costs can be more or less complicated depending on the type of structure and type of repair. It is easier to establish a model which estimates the stop costs of the buildings, with almost constant and known incomes and expenses, than to establish a model which estimates the stop costs of roads, bridges and building complexes such as malls.

Models for estimation of traffic stop costs can be found in [19] and [8].

Operational costs and returns

The information regarding operational costs/returns can come from the owner and the contractor. The information may be based on their own experiences. The operational costs/returns can be originated from; reduction/increase of income from the assets, reduction/increase of market shares, and good-will, etc. Other sources of the operational costs/returns are those related to the effects on the environment, and costs/returns imposed to the third party and changes on the increased insurance value.

Maintenance costs

The data regarding maintenance costs can come from the owner and the contractor. The data can be based on the experience, i.e. data from the similar repairs, or results of the empirical and semi-empirical models. The data may include the service life of a repair system and their impact on the service life of the structure. The data may also be used to estimate the failure costs. The probability of the failure is a decisive factor in determining the costs of failure. Factors influencing the maintenance costs are as followed:

- The start time, duration, recurrence, and type of maintenance
- Type and contents of the maintenance work
- Costs of the maintenance work and its future development
- Consequences of the postponed maintenance
- Need of education for the workmanship

Residual value

The information about residual value comes from the owner and the contractor. Issues to be considered are:

- Future costs related to the removal of the repair system
- Costs and environmental tolls related to the dumping of the repair system
- Residual value of the repair system

Failure costs

The cost of failure can be divided into several parts. A possible subdivision is shown below:

1. Costs of collapse involving: cost of lives and injuries; cost of replacement of the structure and equipments; cost of loss of architectural, cultural and historical values; stop costs.
2. Costs of unsuccessful repair caused either by defective execution, choosing non-appropriate repair system or both involving: cost of repeating the repair and complementary works; cost of reduction of expected service life; cost of increased inspection and maintenance; cost of causing or accelerating another type of damage.

The first group should not be considered when comparing repair options or repair systems, because no repair option/systems should undergo economical evaluation unless they fulfil basic structural safety requirements. Furthermore, the future degradation of the repair system must be understood, and unknown repair systems should not be applied on the sensitive parts of the structure. Nonetheless, the insurance value of the structure can be used if it is found necessary to account for this type of costs. However, it is complicated to involve such costs in the calculations. The relationship between the failure of the repair, the failure of the structure and the consequences must be clearly described.

The second group, however, should be accounted for in the economical evaluation, although it might be complicated. When a repair system fails three measures, which involve costs, may be taken:

1. extra maintenance in addition to the ordinary maintenance,
2. minor repair and partial repair with the same type of system and
3. removal of the repair and re-repair of the structure with the same or another type of system.

The induced failure cost is then the cost, caused by the abovementioned measures, multiplied by the failure probability of the initial repair system. Major owners with a large asset portfolio may have information about some repair system in their asset inventory. It is possible to determine the degradation function for those repair systems. In this way it is possible to estimate the failure probability of the repair system. It is difficult to determine the failure probability of the newly developed repair systems.

Addendum: Illumination of equation 6.5

Let the repair/maintenance action be required every m years. Let the service life be N years. Then the number of actions during the service life can be shown by the following time lines:

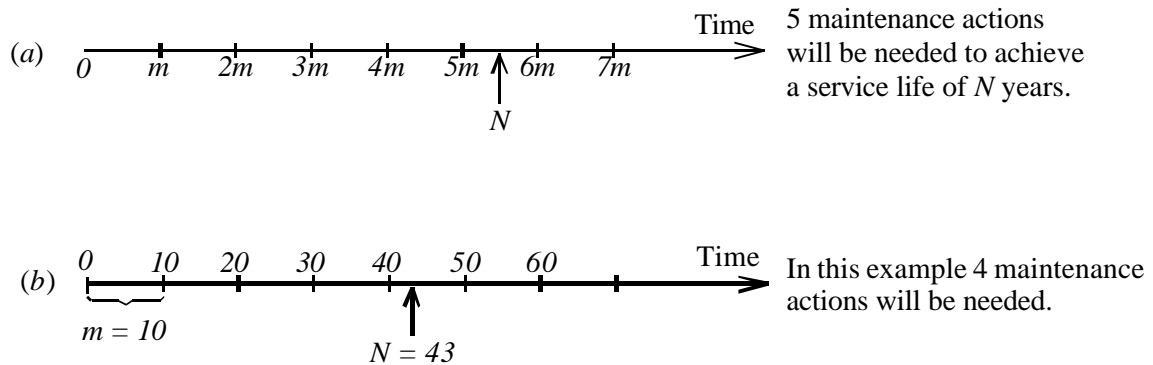

Number of actions during the service life.

The equation $k = \text{trunk}((N-1)/m)$ is obvious from the figure above. In this case k is equal to 4, assuming that the service life is 43 years and the maintenance actions will be needed every 10 years.

The discounted summation of these recurrent costs during the service life is Y_i which is given by:

$$Y_i = \sum_{k=1}^{k=k} y_i (1+r)^{-mk} \tag{6.5b}$$

where y_i is the non discounted recurrent cost, r is discount rate k is the number of maintenance in the service life. Equation 6.5 can be obtained from equation 6.5b if the summation is conducted.

7 CONSIDERATIONS TO NON-TECHNICAL ISSUES (NTI)

Additional information is given in *Annex 7*.

Decisions on repair of structures must consider the technical aspects and the physical condition of the structure in question and the way these factors influence the functional performance of the asset, but in many cases they also need to embrace the wider *political, environmental and socio-economic issues* as well.

Figure 7.1 illustrates the primary headings under which matters are often broadly grouped. These apply to both the construction phase and to the processes for through-life management of an asset. The Functional factors are often referred to as being technical issues, whereas the other topics concerned with Economic, Socio-cultural and Environmental factors are sometimes referred to collectively as being *non-technical issues*.

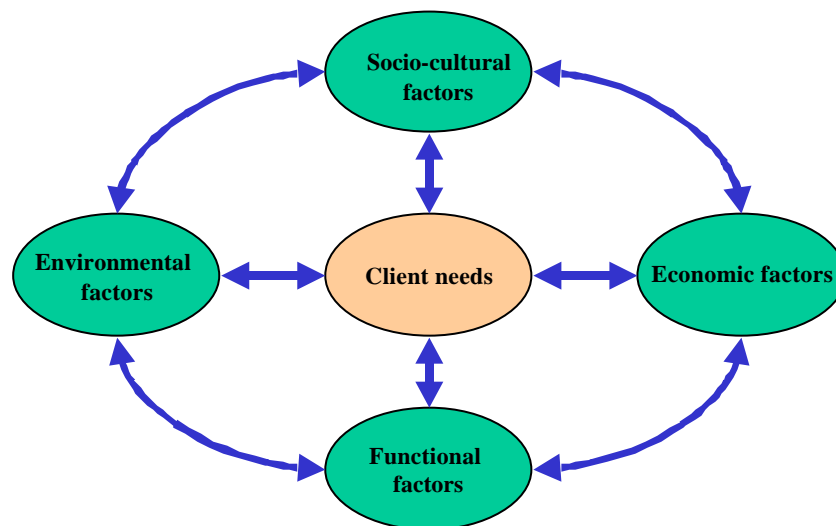

Figure 7.1: Components of sustainable construction for provision of new assets and facilities, as well as for the management of their through-life performance.

Table 7.1 addresses selected non-technical issues and provides some insight as to where their influence might be in the decision making process, with the relevant points being identified in Figure 7.2 via the markers A to G.

Table 7.1: Some aspects of non-technical issues and their interaction in the decision model illustrated in Figure 7.2.

Primary Classification of Requirement	Non-Technical Issue (NTI)	Stage in Decision Making Process						
		A	B	C	D	E	F	G
Economic and Financial	Procurement and type of contract	X						X
	Strength of local economy	X						
	Improvement of asset values			X				
	Effect on third parties	X					X	
	Whole-life cost		X			X	X	X
	Cost versus benefit to society		X		X	X	X	X
	User cost			X	X	X	X	X
	Public confidence			X			X	
Social and Cultural	Target groups			X	X	X		
	Education and training	X				X		
	Aesthetics			X	X	X	X	
	Social perception			X			X	
	Consultation			X				
	Social alarm	X					X	
	Reputation			X			X	
	Media and press	X		X			X	
	Government policies and initiatives		X					X
	Labour union aspects			X	X	X	X	
	Legal issues			X	X	X	X	
	Health and safety requirements			X				X
	Insurance and future liabilities		X	X			X	
	Working environment			X	X	X	X	
	Repair time			X	X	X	X	
Risk and safety	X		X					
Environment	Global environment	X		X	X	X	X	X
	Neighbourhood issues			X	X	X	X	X
	Internal environment		X					X

Figure 7.2, taken in conjunction with Table 7.1, illustrates where various non-technical issues might impact on different stages and aspects of the decision making process.

Non-technical issues and the manner to handle these are further discussed in *Annex 7*.

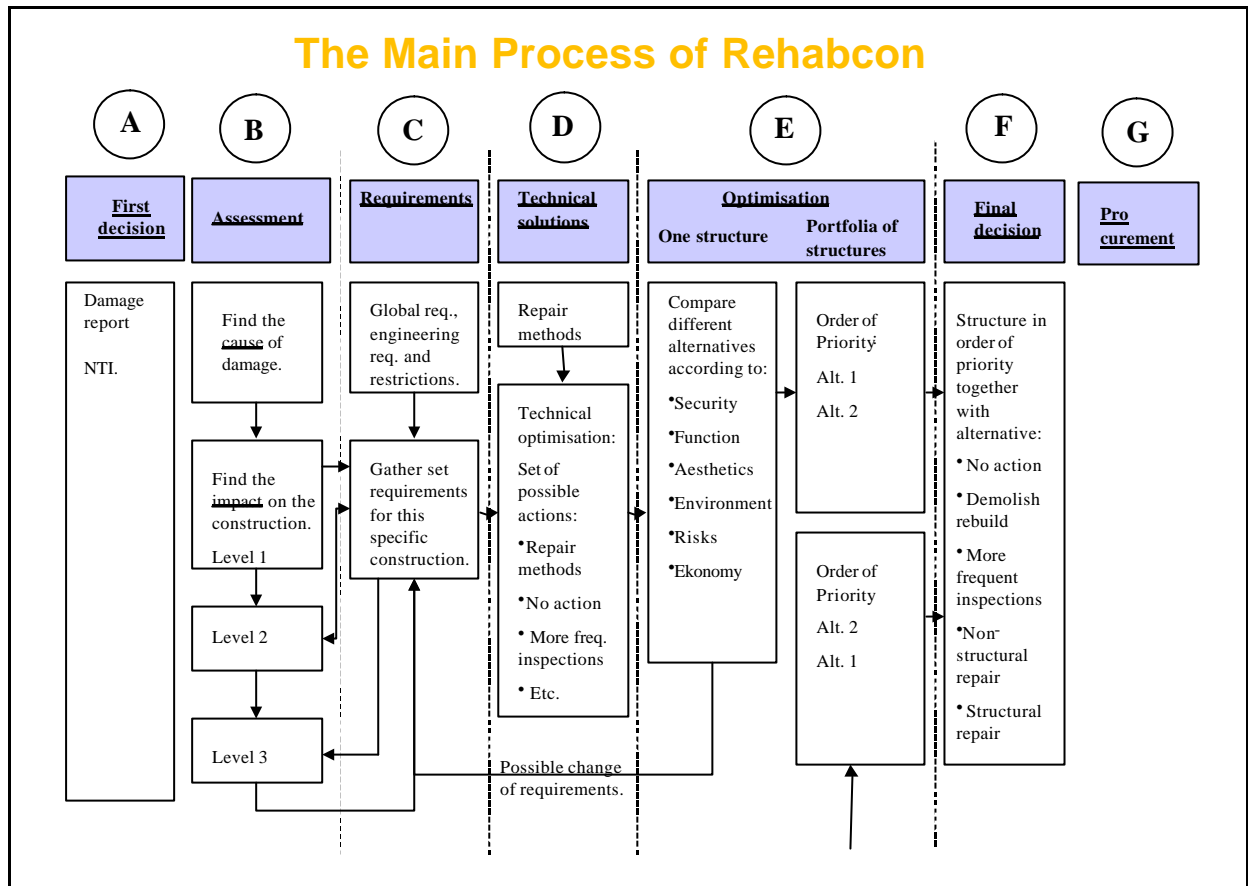

Figure 7.2: Potential interaction of non-technical issues and the overall decision making model described in [27].

References

Paragraph 1, General procedures, and Paragraph 2, Service life

- [1] CONTECVET. *A validated Users Manual for assessing the residual service life of concrete structures*. EC Innovation project IN30902I. Terminated 2001.
- [1a] Andrade, C., Rodriguez, J. (Editors and main authors): *Manual for assessing corrosion-affected concrete structures*. Available from IETcc Madrid.
- [1b] Somerville, G. (Editor and main author): *Manual for assessing concrete structures affected by ASR*. Available from British Cement Association, Crowthorne, UK.
- [1c] Fagerlund, G. (Editor and main author): *Manual for assessing concrete structures affected by frost*. Available from Div. Building Materials, Lund Institute of Technology, Lund, Sweden.
- [1d] Fagerlund, G. (Author): *Leaching of concrete. The leaching process. Extrapolation of deterioration. Effect on structural stability*. Div. Building Materials, Lund Institute of Technology, Report TVBM-3091, Lund, 2000.
- [2] Alberts, C., Strömberg, U.: *Damage on concrete balcony slabs. Following-up of previously made repair*. Swedish Cement and Concrete Research Institute, Report Ra 2:80, Stockholm, 1980. (In Swedish)
- [3] Fagerlund, G., Svensson, O.: *Durability of repair systems for concrete balconies*. Swedish Cement and Concrete Research Institute. Research, Fo 2:80, Stockholm, 1980.
- [4] Nürnberger, U.: *High strength stainless steel. Alternative materials for tension members in civil engineering*. Otto-GrafJournal, Vol. 14, 2003.
- [5] DURACRETE. *Probabilistic performance based on durability design of concrete structures*. EU-Brite EuRam Project BE95-1347. A number of reports available from CUR Centre for Civil Engineering Research and Codes, Gouda, The Netherlands.
- [6] Fagerlund, G.: *Synergetic effects of combined destructive action on concrete*. Contribution to Celebrating Concrete, People and Practice. Conference, Dundee 3-4, September 2003.

Paragraph 3, Structural stability and safety

- [7] EU-Project REHABCON. *Work Package WP2.1 Deliverable, "Market review"*. Geocisa, Madrid 2002.

Paragraph 4, Execution of work

- [8] Silfwerbrand, J., Sundqvist, H.: *Management, maintenance and repair of structures*. Royal Institute of Technology, Division of Building Construction. TRITA-BKN, Report 53, Stockholm, 2001. (In Swedish).

Paragraph 5, Environment and health

- [9] Sarja, A.: *Integrated life cycle design of structures*. Technical Research Centre of Finland. Spon Press, New York, 2002.
- [10] Swedish Building Centre: *Building Product Declarations. Part of the building sector's responsibility for building products*. A publication from the Ecocycle Council for the Building Sector. Printed by AB Svensk Tryck AB, Stockholm 1998.
- [11] EFCA *Environmental Declarations*: EFCA doc.124ETG eu, November 2002
- [12] EFCA *Environmental Declarations*: EFCA doc.125ETG eu, November 2002
- [13] European Chemicals Bureau (ECB): <http://ecb.jrc.it/>
- [14] European Legislation: <http://europa.eu.int/eur-lex/en/index.htm>

Paragraph 6, Economy

- [15] Andersson, G.: *Calculations for decision making* (Kalkyler som beslutsunderlag), Swedish Student Literature, 2001. (In Swedish)
- [16] Bartsch, M.: *Risk analysis-Dams and dam safety (Riskanalys – Dammar och Dammsäkerhet)*. Kraftverksföreningen, Royal Institute of Technology, Stockholm 2001. (In Swedish).
- [17] Bernstone, C., Rådman, J.: *A Management System for Concrete Dams. (Förvaltningssystem för betongdammar)*, 2001. (In Swedish).
- [18] Berntsson, S.: *Dam safety and risk management*. Licentiate Thesis, Royal Institute of Technology, Stockholm, 2001
- [19] BRIME (Bridge Management in Europe), EU-project, *Deliverable D14, Final Report*, March 2001, (www.trl.co.uk/brime/deliver.htm).
- [20] EU-Project REHABCON. *Work Package WP2.2. Definition of performance requirements*. Watford, 2002,
- [21] Johansson, K-E: *Operational security and maintenance – LCC/RCM. (Driftsäkerhet och underhåll – LCC/RCM)*. Swedish Student Literature, 1993. (In Swedish).
- [22] Melchers, R.E.: *Structural reliability analysis and prediction*. Second edition. Wiley & Sons, 1998.
- [23] Nordstrand, U.: *Building Control. (Byggstyrning)*. Läromedel AB, 1990. (In Swedish)
- [24] Holmer Shekofeh, *Private communication*. Swed Power AB, Department of Assessment and Management, Sweden.
- [25] Bergström, S.G., Möller,G., Samuelsson,P. (Editors): *Concrete Handbook - Repair* . Svensk Byggtjänst, Stockholm, 1987. (In Swedish)
- [26] Calculation Handbook. (Kalkylhandbok), Vattenfall, Sweden, 2002. (In Swedish)

Paragraph 7, Non-technical issues

- [27] EU-Project REHABCON. *Work Package WP 3.1 Deliverable, “Integrated management system for concrete structures –Optimisation of measures”*. VUAB,Älvkarleby, 2003.

ANNEX 1

REPAIR PRINCIPLES AND REPAIR METHODS FOR DIFFERENT TYPES OF DAMAGE

QUALITATIVE EVALUATION OF REPAIR METHODS AND MATERIALS

Abstract

- Damage is divided in 10 *damage groups* depending on the appearance and/or fundamental cause of the damage observed.
- Within each damage group there can be some direct *damage causes*.
- Each damage cause might result in some *damage types*.
- For each damage type there is some basic *repair principles*.
- For each repair principle a number of *repair methods and materials* are possible.

In this ANNEX basic repair principles and methods for different damage types and causes are presented.

A qualitative evaluation of these methods is performed with regard to the parameters:

(i) service life, (ii) structural stability, (iii) execution, (iv) environmental effects, (v) economy.

COMMENTS TO THE TABLES

In this Annex a qualitative evaluation is made of different repair principles and methods for frequent types of damage. The result of the evaluation is presented in Tables 1 and 2.

NOTE: Only repair methods that fulfil strict requirements for structural safety and durability are regarded in the tables. Thus, "repair" of cosmetic nature is not considered.

The tables can be used for a condensed *qualitative evaluation* of repair options.

Table 1: Identification of the main repair method

"Damage" is divided in 10 "*damage groups*":

- I: Reinforcement corrosion
- II: Erosive surface attack
- III: Internal expansive attack
- IV: Expansive surface attack
- V: Loss of lime
- VI: Damage caused by moisture movement and thermal movement
- VII: Overload. Accidental load
- VIII: Damage caused by structural load
- IX: Damage in structures with aluminous cement
- X: Aesthetic damage

Each *damage group* has been divided in a number of *damage causes*

Each *damage cause* has been divided in a number of *damage types*.

For each cause and type of damage there are some basic *repair principles*.

The repair principle is transformed into one or more *main repair methods*.

Table 2: Evaluation of main repair methods

In Table 2 repair methods are described and qualitatively evaluated with regard to the five parameters; (i) service life, (ii) structural stability, (iii) execution of work, (iv) environmental effects, (v) economy.

References

In Table 2 the following types of references are made:

1. References to other Annexes added to this report
2. References to the REHABCON Manual
3. References to European Standards
4. References to literature. Most important is:
NORECON: Nordic Network on Repair and Maintenance of Concrete Structures.
Task T2: *Repair Methods*. Report from FORCE, Denmark, 2004.

Table 1: Qualitative identification of the main repair method

I: Reinforcement corrosion			
Cause of damage	Type of damage	Repair principles	Main repair method (see table 2)
I:1 Chloride induced corrosion	I:1.1 Corroded reinforcement. Spalling of cover with or without cracking.	Stop further corrosion. Recast cover. Restore load-carrying capacity and serviceability (durability).	Method 1: "Concrete recasting" Method 2: "Poly mer concrete recasting" Method 3: "Local patch repair"
	I:1.2 Corroded reinforcement. No spalling. Cracking of cover.	Stop further corrosion. Restore load-carrying capacity and serviceability (durability).	Method 1: "Concrete recasting" Method 2: "Polymer concrete recasting" Method 3: "Local patch repair" Method 10: "Cathodic protection" + +Method 6: "Crack injection" Method 11: "Chloride extraction" + +Method 6: "Crack injection"
	I:1.3 Corroded reinforcement. No spalling. No cracking of cover.	Stop further corrosion. Restore load-carrying capacity and serviceability (durability).	Method 1: "Concrete recasting" Method 2: "Polymer concrete recasting" Method 10: "Cathodic protection" Method 11: "Chloride extraction" + +Method 5 "Surface treatment" (if necessary)
	I:1.4 Corrosion not yet started. Threshold concentration almost reached the bar.	Prolong time until start of corrosion.	Method 1: "Concrete recasting" Method 2: "Polymer concrete recasting" Method 4: "Additional cement based cover" Method 5: "Surface treatment" Method 10: "Cathodic protection" Method 11: "Chloride extraction" + +Method 5 "Surface treatment" (if necessary)
	I:1.5 Chloride induced corrosion on pre-tensioned or post-tensioned reinforcement.	Stop further corrosion. Restore load-carrying capacity and serviceability (durability).	Method 7: "New post-tensioned reinforcement" Method 13: " Demolishing/replacement"
I:2 Carbonation induced corrosion	I:2.1 Corroded reinforcement. Spalling of cover with or without cracking.	Stop further corrosion. Renew cover. Restore load-carrying capacity and serviceability (durability).	Method 1: "Concrete recasting" Method 2: "Polymer concrete recasting" Method 3: "Local patch repair"
	I:2.2 Corroded reinforcement. No spalling. Cracking of cover.	Stop further corrosion. Restore load-carrying capacity and serviceability (durability).	Method 1: "Concrete recasting" Method 2: "Polymer concrete recasting" Method 3: "Local patch repair" Method 10: "Cathodic protection" + +Method 6 "Crack injection" Method 11: "Chloride extraction" + +Method 6 "Crack injection"
	I:2.3 Corroded reinforcement. No spalling. No cracking of cover.	Stop further corrosion. Restore load-carrying capacity and serviceability (durability).	Method 1: "Concrete recasting" Method 2: "Polymer concrete recasting" Method 10: "Cathodic protection" Method 11: "Chloride extraction" + +Method 5 "Surface treatment" (if necessary)

ANNEX 1 Repair principles and repair methods. Qualitative evaluation

I: Reinforcement corrosion (continued)			
Cause of damage	Type of damage	Repair principles	Main repair method (see table 2)
I:2 Carbonation induced corrosion (continued)	I:2.4 Corrosion not yet started. Carbonation front almost reached the bar.	Prolong time until start of corrosion.	Method 1: "Concrete recasting" Method 2: "Polymer concrete recasting" Method 4: "Additional cement based cover" Method 5: "Surface treatment" Method 10: "Cathodic protection" Method 11: "Chloride extraction" + +Method 5 "Surface treatment" (if necessary)
II: Erosive surface attack			
Cause of damage	Type of damage	Repair principles	Main repair method (see table 2)
II:1 Salt-frost attack	II:1.1 Surface scaling.	Replace lost concrete section and replace frost damaged concrete by new concrete with high salt frost resistance.	Method 1: "Concrete recasting"
II:2 Mechanical wear by water or cavitation or other means	II:2.1 Evenly eroded surface.	Remove damaged concrete and restore concrete section by application of wear resistant material.	Method 1: "Concrete recasting" Method 2: "Polymer concrete recasting"
	II:2.2 Local erosion, cavitations.	Remove damaged concrete and restore concrete section. Apply wear resistant surface material.	Method 3: "Local patch repair"
II:3 Acid attack	II:3.1 Dissolved surface with mechanical erosion	Remove partly dissolved concrete. Restore concrete sectionn. Apply wear and acid resistant surface material.	Method 1: "Concrete recasting" + +Method 5: "Surface treatment" Method 2: "Polymer concrete recasting" Method 3: "Local patch repair"+ +Method 5 "Surface treatment" (if necessary)
	II:3.2 Dissolved surface without mechanical erosion	Remove weak and soft concrete. Apply acid resistant surface material.	Method 5: "Surface treatment" + +Method 3: "Local patch repair" (if necessary)
III: Internal expansive attack			
Cause of damage	Type of damage	Repair principles	Main repair method (see table 2)
III:1 Alkali silika reaction (ASR)	III:1.1 Internal expansion. Loss of strength and cohesion. Internal and external cracking. Insufficient structural stability.	Restore structural capacity by strengthening procedures. Retard further expansion by decreasing internal moisture level. Sometimes repair is impossible or very risky.	Method 8: "Strengthening with carbon fibers" + +Method 5: "Surface treatment" Method 9: "Strengthening with steel plates" + +Method 5: "Surface treatment" Method 13: "Demolishing/replacement"
	III:1.2 Internal expansion. Loss of strength and cohesion. Internal and external cracking. Sufficient structural stability.	Retard further expansion by decreasing internal moisture level.	Method 5: "Surface treatment"

ANNEX 1 Repair principles and repair methods. Qualitative evaluation

III: Internal expansive attack (continued)			
Cause of damage	Type of damage	Repair principles	Main repair method (see table 2)
III:2 Internal frost attack caused by freezing of cement paste	III:2.1 Internal expansion. Loss of strength and cohesion. Internal and external cracking. Insufficient structural stability.	Restore structural capacity by strengthening procedures. Stop further destruction by reducing moisture content. Sometimes repair is impossible or very risky.	Method 8: "Strengthening with carbon fibers" + +Method 5: "Surface treatment" Method 9: "Strengthening with steel plates" + +Method 5: "Surface treatment" Method 13: "Demolishing/replacement"
	III:2.2 Internal expansion. Loss of strength and cohesion. Internal and external cracking. Sufficient structural stability.	Stop further destruction by reducing moisture content.	Method 5: "Surface treatment"
III:3 Internal frost attack caused by freezing of unsound aggregate	III:3.1 Internal expansion. Loss of strength and cohesion. Internal and external cracking. Insufficient structural stability.	Restore structural capacity by strengthening procedures. Stop further destruction by reducing moisture content. Sometimes repair is impossible or very risky.	Method 8: "Strengthening with carbon fibers" + +Method 5: "Surface treatment" Method 9: "Strengthening with steel plates" + +Method 5: "Surface treatment" Method 13: "Demolishing/replacement"
	III:3.2 Internal expansion. Loss of strength and cohesion. Internal and external cracking. Sufficient structural stability.	Stop further destruction by reducing moisture content.	Method 5: "Surface treatment"
III:4 Sulphate attack	III:4.1 Internal expansion. Loss of strength and cohesion. Internal and external cracking. Insufficient structural stability.	Restore structural capacity by strengthening procedures. Hinder direct contact between concrete and sulfate. Sometimes repair is impossible or very risky.	Method 8: "Strengthening with carbon fibers" + +Method 5: "Surface treatment" Method 9: "Strengthening with steel plates" + +Method 5: "Surface treatment" Method 13: "Demolishing/replacement"
	III:4.2 Internal expansion. Loss of strength and cohesion. Internal and external cracking. Sufficient structural stability.	Hinder direct contact between concrete and sulfate.	Method 5: "Surface treatment"
III:5 Delayed ettringite formation (Delayed cement reaction)	III:5.1 Internal expansion. Cracking. Loss of cohesion. Insufficient structural stability.	Restore structural capacity by strengthening procedures. Stop further destruction by reducing moisture level. In most cases repair impossible.	Method 8: "Strengthening with carbon fibers" + +Method 5: "Surface treatment" Method 9: "Strengthening with steel plates" + +Method 5: "Surface treatment" Method 13: "Demolishing/replacement"
	III:5.2 Internal expansion. Cracking. Loss of cohesion. Sufficient structural stability.	Stop further destruction by reducing moisture level.	Method 5: "Surface treatment"
III:6 Alkali-dolomite reaction	III:6.1 Internal expansion. Loss of strength and cohesion. Internal and external cracking. Insufficient structural stability.	Restore structural capacity by strengthening procedures. Stop further destruction by reducing moisture level. Probably often impossible to repair.	Method 8: "Strengthening with carbon fibers" + +Method 5: "Surface treatment" Method 9: "Strengthening with steel plates" + +Method 5: "Surface treatment" Method 13: "Demolishing/replacement"
	III:6.2 Internal expansion. Loss of strength and cohesion. Internal and external cracking. Sufficient structural stability.	Stop further destruction by reducing moisture level.	Method 5: "Surface treatment"

ANNEX 1 Repair principles and repair methods. Qualitative evaluation

III: Internal expansive attack (continued)			
Cause of damage	Type of damage	Repair principles	Main repair method (see table 2)
III:7 Moisture swelling of coarse aggregate	III:7.1 Internal expansion. Loss of strength and cohesion. Internal and external cracking. Insufficient structural stability.	Restore structural capacity by strengthening procedures Stop further destruction by reducing moisture level. Stop further shrinkage-swelling movements keeping inner moisture constant. Sometimes repair is impossible.	Method 8: "Strengthening with carbon fibers" + +Method 5: "Surface treatment" Method 9: "Strengthening with steel plates" + +Method 5: "Surface treatment" Method 13: "Demolishing/replacement"
	III:7.2 Internal expansion. Loss of strength and cohesion. Internal and external cracking. Sufficient structural stability.	Stop further destruction by reducing moisture level. Stop further shrinkage-swelling movements keeping inner moisture constant.	Method 5: "Surface treatment"
IV: Expansive surface attack			
Cause of damage	Type of damage	Repair principles	Main repair method (see table 2)
IV:1 Alkali silica reaction (ASR)	IV:1.1 "Pop-out" craters in surface. Moisture from outer source.	Stop further pop-outs by reducing moisture level. Renew surface (not always necessary). Drying might be sufficient to stop further pop outs.	Method 1: "Concrete recasting" Method 2: "Polymer concrete recasting" Method 4: "Additional cement based cover" Method 5: "Surface treatment"
	IV:1.2 "Pop-out" craters in surface caused by extended moisture entrapped under dense cover.	Remove cover and let the concrete dry. Renew surface (not always necessary).	Method 1: "Concrete recasting" Method 2: "Polymer concrete recasting" Method 4: "Additional cement based cover"
IV:2 Sea water attack	IV:2.1 Expansive surface attack causing cracking and weakening of surface.	Remove and replace damaged concrete and reinforcement. Stop further seawater attack by using sea water resistant concrete with low chloride diffusivity. Restore load-carrying capacity.	Method 1: "Concrete recasting"
V: Loss of lime, leaching			
Cause of damage	Type of damage	Repair principles	Main repair method (see table 2)
V:1 Leaching by pure or natural water	V:1.1 Dissolution of surface(sort of acid surface attack, c.f. II:3.2).	Remove partially dissolved concrete. Restore surface by material with low solubility in actual water.	Method 1: "Concrete recasting" Method 2: "Polymer concrete recasting"
	V:1.2 Dissolution of interior. Strength loss.	Restore structural capacity by strengthening activities. If possible, restore structural capacity, and reduce future water flow and dissolution by injection of dissolved parts.	The most appropriate measures must be judged in each individual case by assessment of present and future status.
	V:1.3 Dissolution in cracks. Decreased water tightness.	Stop flow in cracks.	Method 6: "Crack injection"

VI: Damage caused by hygric and thermal movement			
Cause of damage	Type of damage	Repair principles	Main repair method (see table 2)
VI:1 Drying shrinkage and autogeneous shrinkage	VI:1.1 Surface cracking.	Seal cracks if required for serviceability and durability.	Method 5: "Surface treatment" Method 6: "Crack injection"
	VI:1.2 Through cracking	Seal cracks if required for serviceability and durability.	Method 6: "Crack injection" + +Method 5: "Surface treatment" (if necessary)
VI:2 Thermal shrinkage	VI:2.1 Surface cracking	Seal cracks if required for serviceability and durability.	Method 5: "Surface treatment" Method 6: "Crack injection"
	VI:2.2 Through cracking	Seal cracks if required for serviceability and durability.	Method 6: "Crack injection" + Method 5: "Surface treatment" (if necessary)
VII: Accidental load. Overload			
Cause of damage	Type of damage	Repair principle	Main repair method (see table 2)
VII:1 Surface impact by traffic, or by other accident during service life of structure	VII:1.1 Loss of cover. Exposed reinforcement	Renew cover. Restore load carrying capacity, serviceability and durability	Method 1: "Concrete recasting" + +Method 5 "Surface treatment" (if necessary) Method 3: "Local patch repair"+ +Method 5: "Surface treatment" (if necessary)
	VII:1.2 Loss of cross-section	Restore structural safety, serviceability and durability	Method 1: "Concrete recasting" + +Method 5: "Surface treatment" (if necessary)
VII:2 Overload during the building phase	VII:2.1 Surface cracking	Seal cracks if required for serviceability and durability	Method 5: "Surface treatment" Method 6: "Crack injection"
	VII:2.2 Through cracking	Restore structural safety, serviceability and durability	Method 6: "Crack injection"
VIII: Damage caused by structural load			
Cause of damage	Type of damage	Repair principles	Main repair method (see table 2)
VIII:1 Bending fracture	VIII:1.1 Crush failure in concrete. Cracking	Restore structural safety, serviceability and durability	Method 1: "Concrete recasting" Method 1: "Concrete recasting" + +Method 9: "Strengthening with steel plates" Method 4: "Additional cement based cover"
	VIII:1.2 Yield in main reinforcement	Restore structural safety, serviceability and durability	Method 1: "Concrete recasting" Method 8: "Strengthening with carbon fibers" Method 9: "Strengthening with steel plates"
VIII:2 Anchorage fracture	VIII:2.1 Slip in reinforcement. Crushing of concrete. Cracking	Restore structural safety, serviceability and durability	Method 1: "Concrete recasting" Method 1: "Concrete recasting" + +Method 8: "Strengthening with carbon fibers" or Method 9: "Strengthening with steel plates"

VIII: Damage caused by structural load (continued)			
Cause of damage	Type of damage	Repair principles	Main repair method (see table 2)
VIII:3 Shear fracture	VIII:3.1 Through shear cracks in shear zones.	Restore structural safety, serviceability and durability.	Method 1: "Concrete recasting" Method 8: "Strengthening with carbon fibers" Method 9: "Strengthening with steel plates"
	VIII:3.2 Yield in shear reinforcement.	Restore structural safety, serviceability and durability.	Method 1: "Concrete recasting" Method 8: "Strengthening with carbon fibers" Method 9: "Strengthening with steel plates"
	VIII:3.3 Shear cracks between structural concrete and screed, or other cement-based surface layer. .	Restore structural safety, serviceability and durability.	Remove surface layer. Rinse the sub-base concrete and increase the roughness of the interface. Cast new surface. (Method 1: "Concrete recasting") (Method 5: "Surface treatment")
VIII:4 Fatigue fracture	VIII:4.1 Fracture in concrete.	Restore structural safety, serviceability and durability.	The most appropriate measures must be judged in each individual case by assessment of present and future status. In certain cases Method 8: "Strengthening with carbon fibers" or Method 9: "Strengthening with steel plates" can be considered.
	VIII:4.2 Fracture in bond.	Restore structural safety, serviceability and durability.	Method 1: "Concrete recasting"
	VIII:4.3 Fracture in reinforcement.	Restore structural safety, serviceability and durability.	Method 1: "Concrete recasting" Method 8: "Strengthening with carbon fibers" Method 9: "Strengthening with steel plates"
VIII:5 Compressive fracture caused by local load	VIII:5.1 Crushing failure in concrete.	Restore structural safety and serviceability (e.g. durability).	Method 3: "Local patch repair" (with high-strength concrete)
IX: Damage in structures with aluminous cement			
Cause of damage	Type of damage	Repair principles	Main repair method (see table 2)
IX:1 Conversion of hydration products to products with low strength	IX:1.1 Loss of cohesion, strength and stiffness.	Restore structural safety by strengthening procedures. Often, repair is impossible.	The most appropriate measures must be judged in each individual case by assessment of present and future status

ANNEX 1 Repair principles and repair methods. Qualitative evaluation

X: Aesthetic damage			
Cause of damage	Type of damage	Repair principles	Main repair method (see table 2)
X:1 Efflorescence	X:1.1 Discoloration	Remove lime deposits on surface	Mechanical removal (e.g. steel brushing, sandblasting) and/or chemical removal (washing with diluted HCl) + Method 5: "Surface treatment" (if necessary)
X:2 Soiled surface due to deposits of dust, dirty precipitation, etc.	X:2.1 Discoloration	Clean the surface	Mechanical removal (e.g. flame-cleaning, sandblasting) and/or chemical removal + Method 5: "Surface treatment"

Table 2: Qualitative evaluation of main repair methods

Main repair method		Variations/Considerations/Risks				
Method no	Short description	Service life	Structural stability	Execution	Environment and health	Economy
Method 1: Concrete recasting	<p>Remove all chloride contaminated, carbonated, cracked or defective concrete. Additional reinforcement (if necessary). Inject cracks (if necessary). Cast new concrete cover. (Make surface finish for aesthetic reason).</p> <p>Concrete can be cast or sprayed. Reinforcement can be stainless. Steel fibre concrete can be used. Satisfy principle 3, (4) and 7 in ENV 1504-9.</p>	<p>Damaged concrete is removed to the depth of intact concrete. Adhesion is fundamental (shall be tested). Quality of new concrete must be high to secure long service life.</p> <p><i>Corrosion:</i> A new concrete with low permeability (e.g. concrete with low w_b/c-ratio) reduces future chloride ingress and carbonation. The binder influences the threshold value and chloride binding capacity.</p> <p><i>Salt-frost attack:</i> New salt-frost resistant concrete shall be used. The risk of internal frost damage in the old concrete due to dense concrete cover shall be considered.</p> <p><i>Mechanical wear:</i> Concrete should have very high strength and contain wear-resistant aggregate.</p> <p><i>Pop-out:</i> If lower moisture content cannot be achieved the new concrete layer must be able to withstand further ASR in the substrate without cracking or delaminating. Steel fibre concrete might be necessary.</p> <p><i>Sea water attack:</i> Possible synergy with chloride induced corrosion and frost attack must be considered.</p> <p><i>Leaching:</i> Concrete with low solubility (containing pozzolans, low w_b/c-ratio) should be used.</p> <p>Advisable references: This Report, Annex 2 <i>European standards:</i> EN 206, prEN 1504-3, prEN 1504-4...</p>	<p>Adhesion and shear bond is fundamental. Dowels might be needed but water-jetted substrates normally give sufficient adhesion and shear bond strength.</p> <p>Compatibility is normally good when concrete is used.</p> <p>Removal of load and propping may be essential.</p> <p>Advisable references: This Report Annex 3 Manual, Annex I <i>European standards:</i> prEN 1504-3 prEN 1504-4 Eurocode 1 Eurocode 2</p>	<p>All steps, i.e. concrete removal, preparation of substrate, material selection, casting and curing, must be performed correctly. To ensure bond with the substrate pre-preparation is crucial. Excellent workmanship is essential. Many steps in this method may cause production of noise, dust and other hazardous materials. Therefore protection of workmanship and surrounding environment may be required.</p> <p>The old and damaged concrete can be removed by different methods, namely blasting, milling, mechanical hammering, water-jetting, grinding, sawing and drilling. The properties of the remaining concrete are highly influenced by the applied method.</p> <p>If necessary the surface of concrete must be cleaned before casting. Among the cleaning methods can be mentioned: Mechanical cleaning (brushing), chemical cleaning, dry and wet sandblasting, water-jet blasting, Acid etching and steam cleaning.</p> <p>The reinforcement can be cleaned by means of dry and wet sandblasting, water-jet blasting, wire brushing, sand paper and rust converters.</p> <p>Advisable references: WP2.3 Final Report, Annex 4 Manual, Annex H <i>European standards:</i> EN 1504-10, ...</p>	<p>The effect on ecology, indoor environment and health and safety during the entire lifetime of the repair should be considered.</p> <p><i>Ecology:</i> The effect to be considered is the emission of CO₂ from the production of cement. The volume of repair concrete is often low giving also a low ecology impact.</p> <p><i>Health and Safety:</i> Cement based products are corrosive to skin and eyes. Skin and eyes have to be protected. Always read Safety Data Sheet.</p> <p><i>Indoor environment:</i> Risk of emissions if surface layer is applied before cement-based product has dried out.</p> <p>Advisable references: This Report Annex 5 <i>European standards:</i> EC Directive 91/155/EC ...</p>	<p>Repair and remedial actions prolong the service life of the structure, and can be considered as an investment. The investment analysis may be performed within a LCC context because in this way it is possible to account for costs caused by failure, environment tolls, demolition, risks, etc. However, it should be noted that some of the decisive events/factors in an economical evaluation happen in a remote future, and the future is not easy to predict at least when the economical development is concerned. Among the costs can be mentioned Initial costs, Stop costs, Operational costs and returns, Maintenance costs, Residual value, Failure costs. The basic calculation factors needed are: Service life and the economical life time; Interest, discount and inflation rates.</p> <p>Advisable references: This Report, Annex 6</p>

ANNEX 1 Repair principles and repair methods. Qualitative evaluation

Main repair method		Variations/Considerations/Risks				
Method no	Short description	Service life	Structural stability	Execution	Environment and health	Economy
Method 2: Polymer concrete recasting	As Method 1: but with polymer based concrete or mortar. Satisfy principle 3 (and 4) in ENV 1504-9.	The polymer must be alkali-resistant. Might freeze loose. Thermal incompatibility can cause loss of adhesion and cracks. Risk of low service life. <i>Corrosion:</i> More risky than Method 1. Pure polymer mortar does not absorb chloride and carbon dioxide. <i>Mechanical wear:</i> The material should be tested for its wear resistance. <i>Acid attack:</i> The polymer must be acid resistant. <i>Pop-out:</i> If lower moisture content cannot be achieved the new concrete layer must be able to withstand further ASR in the substrate without cracking or delaminating. <i>Leaching:</i> Cannot be used if leaching has activated reinforcement corrosion. Few polymers are long-term resistant with sea water on one side and alkaline concrete on the other side. Advisable references: <i>This Report, Annex 2</i> <i>European standards:</i> prEN 1504-3, ...	Compatibility must be taken into consideration. Differences in strength and E-modulus may cause problems.	See method 1.	The effect on ecology, indoor environment and health and safety during the entire lifetime of the repair should be considered. The impact depends on type of polymer used. <i>Ecology:</i> The effect on different ecology parameters (energy, emissions etc.) is evaluated for all life cycle phases of the repair. <i>Health and Safety:</i> Handling of products is regulated in the EC legislation. Relevant information is found in the Safety Data Sheet. <i>Indoor environment:</i> To be considered only at indoor repair activity. Parameters like self-emissions, sound etc. are evaluated. Advisable references: <i>This Report, Annex 5</i> <i>European standards:</i> EC Directive 91/155/EC ...	See method 1.
Method 3: Local patch repair	Deteriorated concrete is locally removed and replaced with cast concrete or repair mortar especially made for repairs. Additional reinforcement (if necessary). Local repairs often are supplemented	Properly performed execution is vital. Service life does not depend only on the durability of repaired areas. Degradation of other areas will often determine the actual service life of local repaired structures. <i>Corrosion:</i> A new concrete with low permeability (e.g. concrete with low w_0/c -ratio) reduces future chloride ingress and carbonation. The binder influ-	Can on its own only be used when residual load-carrying capacity is high enough.	See method 1.	The effect on ecology, indoor environment and health and safety during the entire lifetime of the repair should be considered. <i>Ecology:</i> The effect to be considered is the emission of CO ₂ from the production of cement. The volume of repair mortar is often low giving also a low impact on ecology. <i>Health and Safety:</i> Cement	See method 1.

ANNEX 1 Repair principles and repair methods. Qualitative evaluation

Main repair method		Variations/Considerations/Risks				
Method no	Short description	Service life	Structural stability	Execution	Environment and health	Economy
	with surface coating or painting. Satisfy principle 3 and 7 in ENV 1504-9.	exceeds the threshold value and chloride binding capacity. Mortars with polymer admixture increase the electrical resistivity. <i>Mechanical wear:</i> Surface must have high wear resistant and strength. Advisable references: <i>This Report, Annex 2</i>			based products are corrosive to skin and eyes. Skin and eyes have to be protected. Always read Safety Data Sheet. <i>Indoor environment:</i> Risk of emissions if tight surface layer is applied before cement-based product has dried out. Advisable references: <i>This Report, Annex 5</i> <i>Manual, Annex G</i> <i>European standards:</i> EC Directive 91/155/EC...	
Method 4: Additional cement based cover	Clean surface (e.g. by sand- or shotblasting). Application of additional cover. Depending on purpose can e.g. steel fibre concrete or chloride absorbing mortar (e.g. mortar based on slag cement) be used. Satisfy principle 4, 6 and 7 in ENV 1504-9.	<i>Corrosion:</i> Chloride in the old cover might continue to penetrate inwards. Needs careful investigation before being used. <i>Pop-out:</i> If lower moisture content cannot be achieved the new concrete layer must be able to withstand further ASR in the substrate without cracking or delaminating. Steel fibre concrete might be necessary. Advisable references: <i>This Report, Annex 2</i>	Adhesion and shear bond is fundamental. Dowels might be needed. Compatibility is normally good when concrete is used. Removal of load and propping may be essential. Advisable references: <i>This Report, Annex 3</i> <i>Manual, Annex 1</i> <i>European Standards:</i> Eurocode 1 Eurocode 2.	See method 1.	The effect on ecology, indoor environment and health and safety during the entire lifetime of the repair should be considered. <i>Ecology:</i> The effect to be considered is the emission of CO ₂ from the production of cement. The volume of mortar is often low giving also a low impact on ecology. <i>Health and Safety:</i> Cement based products are corrosive to skin and eyes. Skin and eyes have to be protected. Always read Safety Data Sheet. <i>Indoor environment:</i> Risk of emissions if tight surface layer is applied before cement-based product has dried out. Advisable references: <i>This Report, Annex 5</i> <i>European standards:</i> EC Directive 91/155/EC	See method 1.

ANNEX 1 Repair principles and repair methods. Qualitative evaluation

Main repair method		Variations/Considerations/Risks				
Method no	Short description	Service life	Structural stability	Execution	Environment and health	Economy
Method 5: Surface treatment	Classified in hydrophobic impregnations, impregnations and coatings. Application prevents deterioration and/or limits the deterioration rate. The main function is moisture control and/or protection against ingress. Satisfy principle 1, 2, 5, 6 and 8 in ENV 1504-9.	Adhesion to substrate is essential. For coatings the crack bridging capacity must be considered on cracked substrate. The product must be durable in its environment and withstand UV-radiation, moisture, alkali, ozone, etc. Temperature cycling and shrinkage can give internal stresses in coatings that might cause cracks and blisters and contribute to degradation. Experience shows that dense thin coatings can cause frost damage. <i>Corrosion:</i> Diffusion of carbon dioxide or chloride through the surface treatment shall be low enough (test required). Moisture control might be a possible way to reduce the corrosion rate. <i>ASR:</i> Moisture control might be a possible way to reduce ASR. Risk that the decrease of moisture content will be insufficient. Advisable references: <i>This Report, Annex 2</i> <i>European standards:</i> prEN 1504-2, ...	Can on its own only be used when residual load-carrying capacity is high enough.	Requires a clean substrate without contaminations (see further method 1 for surface cleaning). For coatings the preparation should aim at obtaining an even surface. Errors in the preparation might lead to insufficient adhesion. Penetration of a hydrophobic agent is strongly effected by the exposure time and the moisture conditions in the concrete cover. For coatings the total thickness shall meet the specified maximum and minimum thickness since many properties depend on the thickness. Application procedure shall follow the recommendations given by the supplier. Advisable references: <i>This Report, Annex 4</i> <i>Manual, Annex F</i> <i>European standards:</i> EN 1504-10, ...	The effect on ecology, indoor environment and health and safety during the entire lifetime of the surface treatment should be considered. The effect depends on type of surface treatment used. <i>Ecology:</i> The effect on different ecology parameters (energy, emissions etc.) is evaluated for all life cycle phases of the repair. <i>Health and Safety:</i> Handling of products is regulated in the EC legislation. Relevant information is found in the Safety Data Sheet. <i>Indoor environment:</i> To be considered only at indoor repair activity. Parameters like self-emissions, sound etc. are evaluated. Advisable references: <i>This Report, Annex 5</i> <i>European standards:</i> EC Directive 91/155/EC.	See method 1. Normally the cost of surface treatments is relatively low in comparison with most other repair techniques. New costs for periodical maintenance might arise.
Method 6: Crack injection	The purpose of the injection is to tighten, protect from aggressive compounds and/or strengthening. The injection material can be divided into three classes depending on their material composition: (i) hydraulic binders, (ii) polymer binders and (iii) gels.	It is fundamental the cracks totally filled. Polymer based products and concrete have different thermal expansion and shrinkage. Only cement-based products will protect steel from corrosion. The product must be compatible with the concrete, the reinforcement and possible water stopper. Injection of cracks is normally only required if the environment is aggressive to reinforcement and the crack is wide	Products for force transmitting filling of cracks are products, which are able to bond to the concrete surface and transmit forces across them. Both hydraulic binders and polymer binders can be used for force transmitting fillings. The product must fulfil requirements for strength and bonding for the present moisture state and possible movements during hardening. The product must also be com-	When epoxy is used the cracks must be dried out and sealed on all sides. If cracks are still leaking these materials are not applicable. If low pressure injection is used, long pot life is necessary. Cannot be used for crack widths smaller than 0.05 mm. Should be applied with in the temperature interval 6-25°C. Pre-sealing of cracks are not necessary when Polyurethane resin is applied. This compound should be applied with high pressure and at temperatures	The effect on ecology, indoor environment and health and safety during the entire lifetime of the repair should be considered. <i>Ecology:</i> The effect on different ecology parameters (energy, emissions etc.) is evaluated for all life cycle phases of the repair. The volume of material used is often very small giving also a low impact on ecology. <i>Health and Safety:</i> Depends on type of material. Handling of	See method 1.

ANNEX 1 Repair principles and repair methods. Qualitative evaluation

Main repair method		Variations/Considerations/Risks				
Method no	Short description	Service life	Structural stability	Execution	Environment and health	Economy
	<p>The products can also be classified in three categories according to their intended use: (i) force transmitting filling, (ii) ductile filling and (iii) swelling fitted filling.</p> <p>Satisfy principle 1, 2 and 4 in ENV 1504-9.</p>	<p>(>0.2 mm).</p> <p>Advisable references: <i>This Report, Annex 2</i> <i>European standards:</i> prEN 1504-5.</p>	<p>patible with the concrete and the reinforcement.</p> <p>Advisable references: <i>This Report, Annex 3</i> <i>European standards:</i> prEN 1504-5, Eurocode 1 and Eurocode 2.</p>	<p>higher than 5°C. The compound should not be applied on crack width larger than 0.2 mm.</p> <p>Cement suspensions are best applied at low pressure. The suspension does not completely fill the cracks. Can be applied on moist cracks. Should not be applied on crack width larger than 0.2 mm.</p> <p>Advisable references: <i>This Report, Annex 4</i> <i>Manual, Annex G</i></p>	<p>products is regulated in the EC legislation. Relevant information is found in the Safety Data Sheet.</p> <p><i>Indoor environment:</i> To be considered only at indoor repair activity. Parameters like self-emissions, sound etc. are evaluated.</p> <p>Advisable references: <i>This Report, Annex 5</i> <i>European standards:</i> EC Directive 91/155/EC ...</p>	
Method 7: New post-tensioned reinforcement	<p>Add new post-tensioned reinforcement replacing the corroding.</p> <p>Satisfy principle 4 in ENV 1504-9.</p>	<p>Chloride corrosion on prestressing steel is very dangerous because of rapid pitting. It is hardly possible to repair corroded steel. New steel or replacement of structure is normally required.</p>	<p>Removal of load and propping may be necessary.</p> <p>The force flow may have to be redistributed.</p> <p>Advisable references: <i>This Report, Annex 3</i> <i>Manual, Annex I and L</i> <i>European Standards:</i> Eurocode 1 Eurocode 2.</p>	<p>Unloading may be required. Some abutment is needed for anchorage. Reinforcement must be placed externally. Needs careful design. Corrosion protection is required.</p> <p>Advisable reference: <i>This Report, Annex 4</i> <i>Manual, Annex I and L</i></p>	<p>The effect on ecology, indoor environment and health and safety during the entire lifetime of the repair should be considered.</p> <p><i>Ecology:</i> The effect on different ecology parameters (energy, emissions etc.) is evaluated for all life cycle phases of the repair.</p> <p><i>Health and Safety:</i> Handling of products is regulated in the EC legislation. Relevant information is found in the Safety Data Sheet.</p> <p><i>Indoor environment:</i> To be considered only at indoor repair activity. Parameters like self-emissions, sound etc. are evaluated.</p> <p>Advisable references: <i>This Report, Annex 5</i> <i>European standards:</i> EC Directive 91/155/EC ...</p>	See method 1

ANNEX 1 Repair principles and repair methods. Qualitative evaluation

Main repair method		Variations/Considerations/Risks				
Method no	Short description	Service life	Structural stability	Execution	Environment and health	Economy
Method 8: Strengthening with carbon fibers	Carbon fiber is externally bonded to the concrete. Carbon fiber rods can also be bonded in slots in the concrete cover. Satisfy principle 4 in ENV 1504-9.	The durability of carbon fibers is high. The critical point is the adhesive combining the carbon fiber with the concrete. Experience from strengthening with steel plates shows that the service life exceeds 30 years. <i>Frost action:</i> There is an obvious risk that moisture becomes entrapped behind the dense carbon fiber composite resulting in frost damage. <i>Fire:</i> The adhesive is not durable at high temperatures. <i>Moisture absorption:</i> Degradation of polymer composites is related to the rate of sorption. This effect is more marked at high temperatures. <i>Thermal incompatibility:</i> Thermal expansion of carbon fiber reinforced polymer in approx. 0 (for concrete the value is approx. $10 \cdot 10^{-6} \text{ K}^{-1}$). <i>Ultraviolet radiation:</i> The adhesive should be protected against UV-radiation. <i>Accidental damage:</i> The carbon fiber normally is installed on the concrete surface and can thus easily be subjected to accidental damage (e.g. lorry that run in to bridge deck). Advisable references: <i>This Report, Annex 2</i>	Removal of load and propping may be necessary. The force flow may have to be redistributed. Advisable references: <i>Manual, Annex J</i> <i>Täljsten: FRP-strengthening of existing concrete structures. Design Guidelines. Luleå Technical University, 2002.</i> <i>European Standards:</i> prEN 1504-3, prEN 1504-4, Eurocode 1 and Eurocode 2.	When Carbon fiber reinforced polymers are used the de-graded concrete must be removed. Surface concrete must be made even. Sandblasting may be required. Epoxy and similar adhesives requires clean and dry surface. Unloading of the structure is often needed. Tensile strength of concrete must be >1 MPa. FRP must be protected from fire and sun. Epoxy cannot be used below 5°C. Non-reacted epoxy used as adhesive can cause allergy. Protection is required. Advisable references: <i>This Report, Annex 4</i> <i>Manual, Annex J</i>	The effect on ecology, indoor environment and health and safety during the entire lifetime of the repair should be considered. <i>Ecology:</i> The effect on different ecology parameters (energy, emissions etc.) is evaluated for all life cycle phases of the repair. The volume of material used is very low giving also a low impact on ecology. <i>Health and Safety:</i> Adhesive material is often epoxy. Personal protecting equipment is very important. Handling of products is regulated in the EC legislation. Relevant information is found in the Safety Data Sheet. <i>Indoor environment:</i> To be considered only at indoor repair activity. Parameters like self-emissions, sound etc. are evaluated. Advisable references: <i>This Report, Annex 5</i> <i>European standards:</i> EC Directive 91/155/EC ...	See method 1

ANNEX 1 Repair principles and repair methods. Qualitative evaluation

Main repair method		Variations/Considerations/Risks				
Method no	Short description	Service life	Structural stability	Execution	Environment and health	Economy
Method 9: Strengthening with steel plates	Steel plates are externally bonded to the concrete. Satisfy principle 4 in ENV 1504-9.	<p>The steel plate must be protected against corrosion. The adhesive combining the steel plate with the concrete is a critical point. Experience from strengthening with steel plates shows that the service life exceeds 30 years.</p> <p><i>Frost action:</i> There is an obvious risk that moisture becomes entrapped behind the steel plates resulting in frost damage.</p> <p><i>Thermal incompatibility:</i> Thermal incompatibility between the adhesive and concrete/steel can cause loss of adhesion and cracks.</p> <p><i>Accidental damage:</i> The steel plates normally are installed on the concrete surface and can thus easily be subjected to accidental damage (e.g. lorry that run in to bridge deck).</p> <p>Advisable references: <i>This Report, Annex 2</i></p>	<p>Removal of load and propping may be necessary.</p> <p>The force flow may have to be redistributed.</p> <p>Advisable references: <i>This Report, Annex 3</i> <i>Manual, Annex K</i> <i>European Standards:</i> prEN 1504-3, prEN 1504-4, Eurocode 1 and Eurocode 2.</p>	<p>Degraded concrete must be removed. Surface concrete must be made even. Epoxy and similar adhesives requires clean and dry surface. Unloading of the structure often needed.</p> <p>Width of plates should be over 200 mm. Plates are joined to concrete with mechanical anchors and epoxy adhesive. Plates must be protected against fire. Concrete quality must be over 17.5 MPa. Not recommendable where temperatures over 55°C are expected. Non-reacted epoxy used as adhesive can cause allergy. Protection is required.</p> <p>Advisable references: <i>This Report, Annex 4</i> <i>Manual, Annex K</i></p>	<p>The effect on ecology, indoor environment and health and safety during the entire lifetime of the repair should be considered.</p> <p><i>Ecology:</i> The effect on different ecology parameters (energy, emissions etc.) is evaluated for all life cycle phases of the repair. The volume of material used is very low giving also a low impact on ecology.</p> <p><i>Health and Safety:</i> Adhesive material is often epoxy. Personal protecting equipment is very important. Handling of products is regulated in the EC legislation. Relevant information is found in the Safety Data Sheet.</p> <p><i>Indoor environment:</i> To be considered only at indoor repair activity. Parameters like self-emissions, sound etc. are evaluated.</p> <p>Advisable references: <i>This Report, Annex 5</i> <i>European standards:</i> EC Directive 91/155/EC ...</p>	See method 1

ANNEX 1 Repair principles and repair methods. Qualitative evaluation

Main repair method		Variations/Considerations/Risks				
Method no	Short description	Service life	Structural stability	Execution	Environment and health	Economy
Method 10: Cathodic protection	<p>Cathodic protection is based on moving the potential of the steel to more negative values, reducing potential differences between anodic and cathodic sites and thus reducing the corrosion current to negligible values. Two main methods are used: (i) sacrificial anodes or (ii) impressed current. Most systems are impressed current.</p> <p>Satisfy principle 10 in ENV 1504-9.</p>	<p>Cathodic protection might involve risks. Need careful investigation by expert before applied. Need continuous supervision</p> <p><i>Concrete degradation:</i> Theoretically, the increase of alkalinity around the reinforcement can cause damage if the concrete contains alkali- reactive aggregates. Acid is produced by the anodic reactions that may dissolve the alkaline species in the concrete at the interface anode/concrete.</p> <p><i>Adhesion:</i> At very negative, loss of adhesion between rebar and concrete can occur. This problem is mainly associated with plain bars.</p> <p><i>Embrittlement of steel:</i> High strength steels used in pre-tensioned or post-tensioned reinforcement can be subjected to hydrogen embrittlement if their potential has values at which hydrogen evolution can take place.</p> <p>Advisable references: <i>Manual, Annex D</i> <i>NORECON, Task T2</i> <i>Standards:</i> EN 12696. CEN/TC262/SC2/WG2. NACE, 1990, STANDARD RP0290-9..</p>	<p>Can only be used when residual load-carrying capacity is high enough.</p>	<p>The method is sophisticated and complicated. Know-how is restricted to companies marketing cathodic protection systems. Therefore, a general evaluation of execution cannot be performed.</p> <p>Advisable references: <i>Manual, Annex D</i> <i>NORECON, Task T2</i></p>	<p>The effect on ecology, indoor environment and health and safety during the entire lifetime of the repair should be considered.</p> <p><i>Ecology:</i> The effect on different ecology parameters (energy, emissions etc.) is evaluated for all life cycle phases of the repair.</p> <p><i>Health and Safety:</i> Handling of products is regulated in the EC legislation. Relevant information is found in the Safety Data Sheet.</p> <p><i>Indoor environment:</i> To be considered only at indoor repair activity. Parameters like self-emissions, sound etc. are evaluated.</p> <p>Advisable references: <i>European standards:</i> EC Directive 91/155/EC ...</p>	<p>See method 1</p> <p>The costs include the initial cost for installing cathodic protection, including the cost of repairs. Operation costs comprise the cost of annual inspections. After some ten to 25 years, the system needs maintenance, such as replacement of power units, monitoring electrodes and possibly parts of the anode system.</p>

ANNEX 1 Repair principles and repair methods. Qualitative evaluation

Main repair method		Variations/Considerations/Risks				
Method no	Short description	Service life	Structural stability	Execution	Environment and health	Economy
Method 11: Chloride extraction	Chloride ions are removed from chloride-contaminated concrete through ion migration. An anode embedded in an electrolyte media is attached to the surface of the concrete. The anode and the reinforcing steel in the concrete (cathode) are connected to a power supply. Satisfy principle 7 in ENV 1504-9.	The experience of chloride extraction is limited and therefore an unsafe method. <i>ASR:</i> During chloride extraction, hydroxide ions are formed around the reinforcing steel, locally increasing the pH and sodium and potassium ions are enriched around the steel. These changes might stimulate ASR. Advisable references: <i>Manual, Annex D</i> <i>NORECON, Task T2</i>	Can only be used when residual load-carrying capacity is high enough.	These methods are sophisticated, complicated and seldom used. Know-how is primarily restricted to companies marketing the methods. Therefore, a general evaluation of execution cannot be performed. Advisable references: <i>Manual, Annex D</i> <i>NORECON, Task T2</i>	The effect on ecology, indoor environment and health and safety during the entire lifetime of the repair should be considered. <i>Ecology:</i> The effect on different ecology parameters (energy, emissions etc.) is evaluated for all life cycle phases of the repair. <i>Health and Safety:</i> Handling of products is regulated in the EC legislation. Relevant information is found in the Safety Data Sheet. <i>Indoor environment:</i> To be considered only at indoor repair activity. Parameters like self-emissions, sound etc. are evaluated. Advisable references: <i>European standards:</i> EC Directive 91/155/EC ...	See method 1
Method 12: Realkalisation	Alkali ions are transported from the surface to carbonated concrete around the steel through ion migration. An anode embedded in an electrolyte media is attached to the surface of the concrete. The anode and the reinforcing steel in the concrete (cathode) are connected to a power supply. Satisfy principle 7 in ENV 1504-9.	Advisable references: <i>Manual, Annex D</i> <i>NORECON, Task T2</i>	Can only be used when residual load-carrying capacity is high enough.	These methods are sophisticated, complicated and seldom used. Know-how is primarily restricted to companies marketing the methods. Therefore, a general evaluation of execution cannot be performed. Advisable references: <i>Manual, Annex D</i> <i>NORECON, Task T2</i>	The effect on ecology, indoor environment and health and safety during the entire lifetime of the repair should be considered. <i>Ecology:</i> The effect on different ecology parameters (energy, emissions etc.) is evaluated for all life cycle phases of the repair. <i>Health and Safety:</i> Handling of products is regulated in the EC legislation. Relevant information is found in the Safety Data Sheet. <i>Indoor environment:</i> To be considered only at indoor repair activity. Parameters like self-emissions, sound etc. are evaluated.	See method 1

ANNEX 1 Repair principles and repair methods. Qualitative evaluation

Main repair method		Variations/Considerations/Risks				
Method no	Short description	Service life	Structural stability	Execution	Environment and health	Economy
					Advisable references: <i>European standards:</i> EC Directive 91/155/EC ...	
Method 13: Demolishing /replacement	Demolishing and replacement of the structure/element	The experience from the original structure/element must be considered when the new are built.	The experience from the original structure/element must be considered when the new are built. Advisable references: <i>European Standards:</i> Eurocode 1 Eurocode 2.	The most appropriate procedures must be judged in each individual case.	The effect on ecology, indoor environment and health and safety during the demolishing and the entire life of the new structure should be considered. <i>Ecology:</i> The effect on different ecology parameters (energy, emissions etc.) are evaluated for all life cycle phases of the demolishing and rebuilding. <i>Health and Safety:</i> Handling of products during both demolishing and replacement should be considered. Handling of products is regulated in the EC legislation. Relevant information is found in the Safety Data Sheet. <i>Indoor environment:</i> To be considered only at indoor repair activity. Parameters like self-emissions, sound etc. are evaluated. Advisable references : <i>This Report, Annex 5</i> <i>European standards :</i> EC Directive 91/155/EC.	See method 1

ANNEX 2

EVALUATION WITH REGARD TO SERVICE LIFE QUANTITATIVE EVALUATION

Abstract

This ANNEX is related to paragraph 2 in the Main Document.

Principles for quantitative evaluation of service life of repaired concrete are presented.

The following aspects are treated:

- Effect of repair on the *moisture* state in the old structure and its effect on service life.
- Effect of different principles for repair on the service life of structures damaged by reinforcement corrosion.
- Effect of repair on the service life of concrete damaged by the following mechanisms:
 - Alkali silica reaction
 - Leaching
 - Salt-frost
 - Internal frost action
 - Mechanical erosion
 - Acid attack
- Service life of the repair material
- Durability of bond between old concrete and repair material
- Synergy between different destructive mechanisms
- Required data for evaluation of service life including references to test methods
- Material data for normal concrete

The ANNEX also contains 4 appendices:

- 3 appendices giving a short theoretical background to transport and binding of moisture, carbon dioxide and chloride ions.
- 1 appendix showing an example of a quantitative service life evaluation.

Contents	Page
Preface	5
1 Moisture effects on service life of repair	6
1.1 General	6
1.2 Surface repair and moisture	6
1.3 Internal repair and moisture	10
1.4 Methods of analysing moisture in repaired structure	11
2. Repair of structures already damaged by reinforcement corrosion	12
2.1 General repair principles	12
2.2 Application of a coating or concrete layer on top of the old cover	12
2.3 Replacing the old cover by polymer-based cover	12
2.4 Replacing the old cover by cement-based cover	13
2.5 Chemical and electro-chemical methods	14
3. Repair for prolonging time until onset of reinforcement corrosion	15
3.1 Basic principles	15
3.2 Effect of a dense polymer-based coating on further carbonation	15
3.3 Effect of a dense coating on further chloride penetration	17
3.4 Effect of an additional concrete cover on further carbonation	17
3.5 Effect on an additional concrete cover on further chloride penetration	19
4. Repair of structures affected by ASR	20
5. Repair of structures affected by leaching	21
6. Repair of structures affected by salt-frost erosion	23
7. Repair of structures affected by inner frost damage	24
8. Repair of structures affected by erosive surface attack	26
9. Repair of structures affected by acid attack	27
10. Durability of the repair material itself	29
11. Durability of bond between old concrete and repair material	30
12. Synergistic effects	33
13. Tests of repair materials and repair systems	34
13.1 Repair materials	34
13.2 Repair systems	34
14. Required material data for quantitative evaluation of service life	35
14.1 Data for analyzing the general durability of the repaired structure	35
14.2 Data required for analyzing the interaction between repair material and old concrete	35
15. Material data for normal concrete	42
15.1 Introduction	42
15.2 Moisture fixation	42
15.3 Moisture transport within the hygroscopic range	43
15.4 Capillary absorption of water	44
15.5 Permeability to water under pressure	46
15.6 Carbonation rate	48
15.7 Diffusion of chloride ions	48
15.8 The threshold chloride concentration	48
References	50

APPENDIX 1: Assessment of moisture state in repaired concrete	53
APPENDIX 2: Carbonation after concrete repair	75
APPENDIX 3: Ion redistribution after concrete repair	89
APPENDIX 4: Example of quantitative service life calculation	107

Preface

General principles for quantitative service life assessments are presented in The Manual, Chapter 6, paragraph 6.2.7. In the present Annex practically applicable methods for evaluation of service life of repaired concrete are presented in some more detail, and are applied to frequent damage types. It has to be remembered that such methods are not very precise, and that they are uncertain due to lack of good theories for many destruction types, lack of reliable material data, and lack of good test methods. Moreover, the interaction, mechanically and physically, between the old structural concrete and the repair material is very complex and therefore not easy to express in quantitative terms. Effect of repair on the moisture state in the old concrete is vital for the function of the repaired structure. Analysis of moisture is extremely complicated at the very high moisture levels that are of interest in conjunction with durability problems. Some estimates can however be made as will be described.

Despite these drawbacks, a quantitative service life analysis, although it is not perfect, is helpful in selecting repair materials and methods that have better probability to give good durability of the repaired structure than if only a qualitative evaluation is used. Using quantitative methods also brings an understanding of the function of the repaired structure. It is also helpful in development of new repair materials and repair systems, and in developing test methods for repair materials and combinations of repair material and old concrete.

Note:

In this Annex the quantitative methods are described in very condensed form. The wording “semi-quantitative” often gives a better description. More detailed quantitative methods for service life analysis can be found in other reports, of which can be mentioned reports from the European Brite EuRam project DURACRETE, “*Probabilistic performance based durability design of concrete structures*”. This mainly deals with service life with regard to reinforcement corrosion. Service life models for other destruction types can be found in reference [6].

1 MOISTURE EFFECTS ON SERVICE LIFE OF REPAIR

1.1 General

Moisture plays an important role in almost all destruction types. Therefore, it is essential in a service life evaluation to estimate the effect of repair on the moisture state in the old concrete.

A change in the moisture conditions of the repaired concrete will have a decisive effect on the service life of the structure after repair. Under favourable conditions, like when the structure becomes drier after repair, and it is vulnerable to internal frost damage or ASR, or to chloride induced reinforcement corrosion, one can expect that the rate of the destruction will decrease after repair. However, under unfavourable conditions, drier internal conditions might increase the rate of destruction. One example is when carbonation is a problem. Other problems occur when water accumulates at the interface between the old concrete and the new repair material, e.g. causing the repair layer to scale at freezing, or to loosen due to chemical attack destroying the interface, or due to differential moisture movement (shrinkage/swelling).

The effect of different types of repair and upgrading system on the internal moisture state in different types of structure has to be analysed. This can be done by analysing the global "moisture balance" in the structure before and after repair, considering also local moisture effects at material interfaces.

It must be considered that different types of concrete, having different w/c-ratio and different types of binder and aggregate, have very different moisture properties. Thus, the evaluation of a repair system must be based on known properties of all materials involved. A repair that suits one type of sub-base concrete might be unfavourable for another type.

Methods of calculating time-moisture fields in concrete at different outer moisture and temperature conditions have been developed, see APPENDIX 1. One example of an application of such methods for analysing the moisture-time field in concrete cover at varying outer moisture conditions is given in [1]. In the repair situation there are two separate materials involved and an interface between these. This makes the calculation more complex. There are computer programmes that can handle such situations, provided material data are at hand, [2]. The most difficult problem is to find transport data for the over-hygroscopic range (>98% RH), a range, which is important for structures placed in very wet environment. An experimental method is described in [3].

1.2 Surface repair and moisture

Many types of damage are located to the surface of the concrete. Examples of surface damage are, salt-frost scaling, mechanical erosion, acid attack, spalling caused by reinforcement corrosion. Repair is normally made by rinsing the old damaged concrete and replacing it by new concrete, or by covering the old surface by a sort of coating, normally polymer-based.

A repair or upgrading system applied to the surface of the old structure will inevitably affect the inner moisture state in the old structure. Either the moisture level will increase due to condensation behind the repair/upgrading material, or due to hindered drying, or it will decrease due to a less permeable surface, or due to surface treatment by a hydrophobing agent. The effect on the moisture condition will mainly depend on:

- The relative moisture transport properties of materials in contact (old concrete and repair material). They determine the rate of water transport in the two materials.
- The moisture equilibrium curves of materials in contact. They determine the equilibrium moisture contents at interfaces, and influence the rate of moisture movements in the two materials.

- The sensitivity to cracking of the repair/upgrading material. Cracks will increase inflow of water into the old concrete, and also cause increased inflow of ions and gases to the old concrete.
- The outer micro- and macro-climatic conditions around the structure (temperature and moisture).
- The geometry (design) of the structure.

Examples of the moisture effects on the inner relative humidity in concrete of application of a dense polymer-based coating, or a high quality concrete topping, on a 15 cm thick concrete balcony slab exposed for 1½ years to the Stockholm climate are shown in Figure 1.1, [4]. The “repaired” top surface was exposed to rain, while the bottom surface was protected from direct rain. The measurement was made in three drilled holes, located about 1 metre from the edges of the slab. The RH-gauge was placed on different depths from the bottom surface.

The measurements indicate that the very dense polymer surface coating (9 mm polyester mortar) give higher average RH-level in the sub-base concrete than the more porous concrete topping; 99% RH compared with 91% RH (average value). The reason probably is that moisture cannot be hindered from entering the slab by suction from its bottom surface, and through some defects in the coating. Water is redistributed due to temperature gradients (periodically cool top surface), and it now and then condensates at the cool interface between the coating and the concrete. The water has lower possibility to dry out from a concrete covered by a polymer coating, than it has when the concrete is covered by concrete.

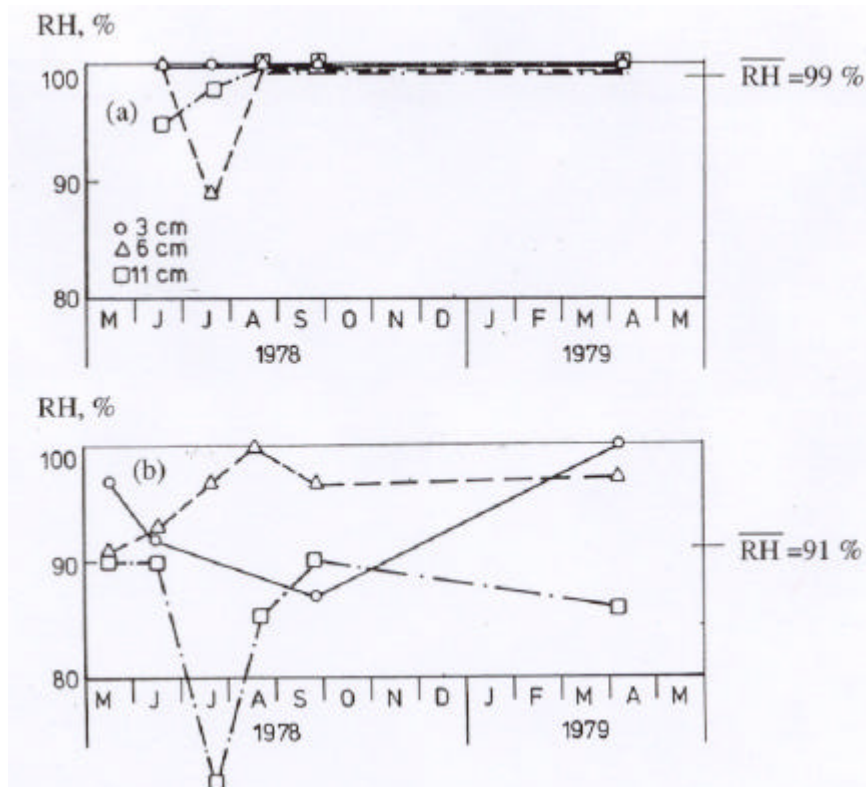
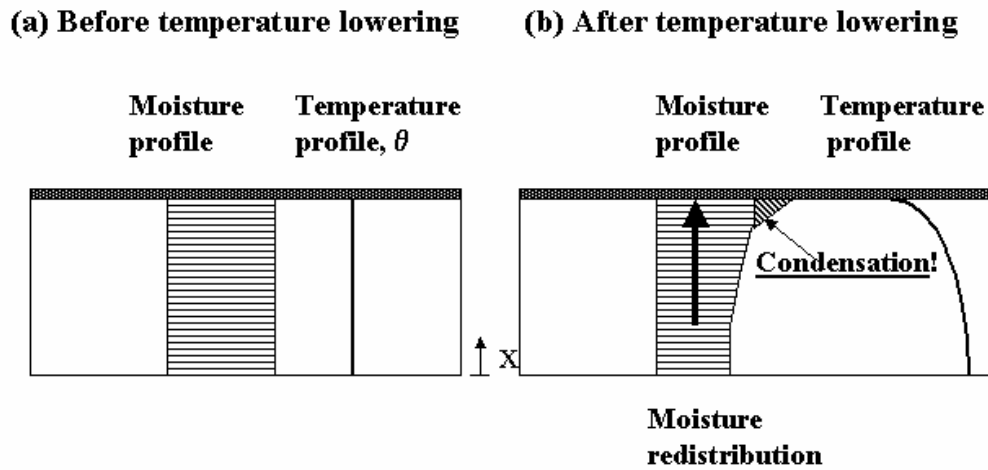

Figure 1.1

Measurements of the RH-level in concrete balcony slabs exposed to Stockholm climate for 1½ years. (a) Concrete covered by 9 mm polyester mortar. (b) Concrete covered by 50 mm concrete layer. Measurements made in vertical holes drilled 1 m from the edge of the slab, and on three different depths from the bottom surface; 30, 60 and 110 mm, [4].

When the concrete surface is rapidly exposed to low temperature, for example when it radiates heat towards the dark sky wintertime, a redistribution of moisture already present in the concrete will occur. Moisture will move towards the lower temperature, i.e. normally towards the outer surface of the structure. When moisture arrives at the interface to a dense coating on the surface, condensation might occur; see Figure 1.2.



$$\text{Water flux} = q_w = -\text{constant} \cdot d\theta/dx$$

Figure 1.2

*A rapid temperature lowering cause moisture transport towards the colder side.
Condensation beneath the coating might occur.*

The redistribution of moisture due to temperature gradients is more rapid the bigger the gradient. Moisture transport is almost directly proportional to the temperature gradient. This means that redistribution close to the interface is more significant under thin dense coatings than under thicker coatings, simply because the temperature gradient is steeper at thin coatings, see Figure 1.3. This also means that one can expect to find higher moisture conditions under thin dense coatings than under thicker coatings, which increases the risk of frost damage and the risk of loosening of the coating. When the surface layer consists of a thick concrete topping, the moisture redistribution is much smaller. Besides, moisture that possibly condenses can be reduced by absorption into the porous concrete topping.

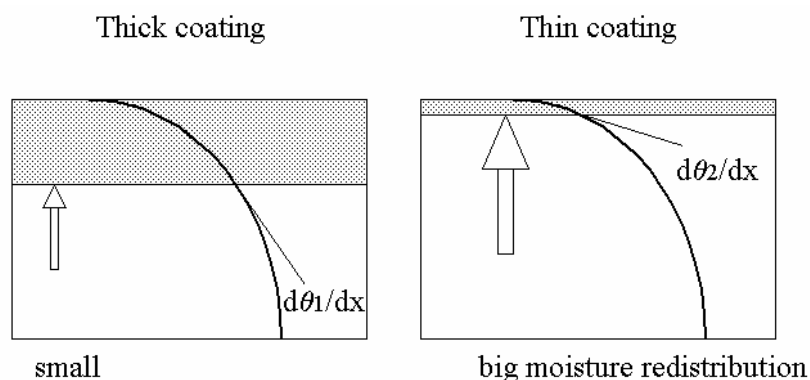

Figure 1.3

*Moisture redistribution under the coating is proportional to the temperature gradient.
Therefore, the risk of condensation is higher the thinner the coating.*

Examples of calculated temperature profiles across coated concrete balcony slabs exposed to a cloud-free winter sky in Sweden are shown in Figure 1.4, [4]. The thicker the coating, the smaller the temperature gradient at the interface between coating and concrete, and, consequently, the smaller is the moisture redistribution. As seen in Figure 4, the temperature gradient changes with time, so in order to find the moisture flow one has to integrate the flow over time. Moreover, when moisture level changes the moisture transport coefficient also changes, which should be considered in a theoretical analysis.

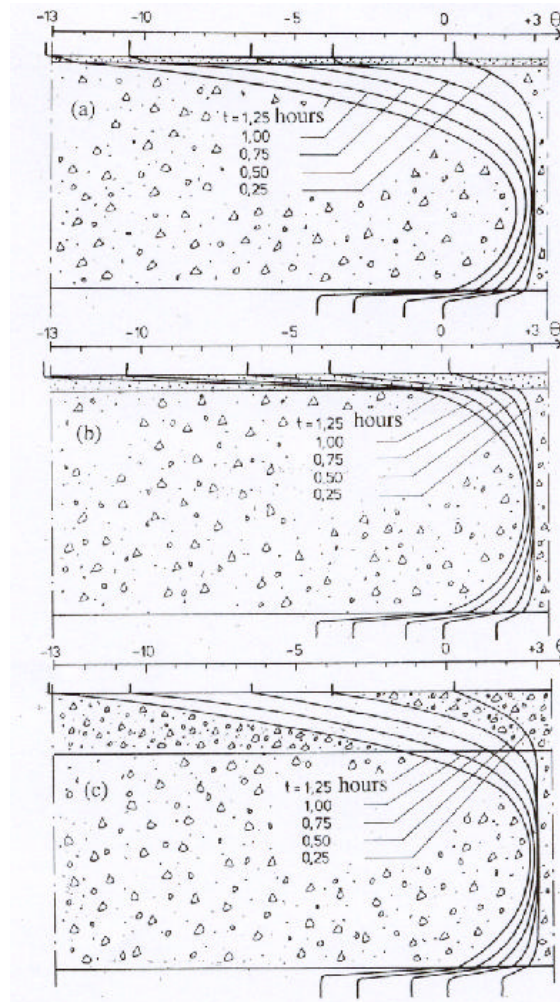

Figure 1.4

Calculated temperature profiles in balcony slabs exposed to a dark cloud free winter sky in Sweden. (a) 0.5 mm polymer coating. (b) 10 mm polymer coating. (c) 40 mm concrete, [4].

Defects in coatings, that are supposed to serve as protection against further destruction of the old concrete, have big influence on the moisture condition in the concrete. A calculation has been made of the effects of thin cracks in a polymer coating on the moisture conditions in a coated concrete structure exposed to rain, see Figure 1.5. In an uncoated slab the waterfront moves as a flat front. In a coated slab with a straight crack it theoretically moves as a cylinder shaped front. The equations for calculating water absorption are given in [4]. It turns out that cracks have very big effect on the water absorption in covered concrete.

Example:

A concrete slab (w/c-ratio 0.60) on which a dense hydrophilic coating is applied, containing visible cracks (width 0.2 mm) with the spacing 0,5 m, has the ability to absorb during 8 hours rain about 10% of the water it should absorb had it been uncoated.

After terminated rain the coated slab dries only downwards while the uncoated slab dries in two directions, upwards and downwards. Consequently, when the slab is not too thin the amount of water dried out from the coated slab is smaller than from the uncoated slab. Besides, water drying out between rains is often smaller than water absorbed during a rain. Therefore, moisture is gradually accumulated in the coated slab.

(a) Uncoated. Plane water front



(b) Coated. Cylinder shaped water front

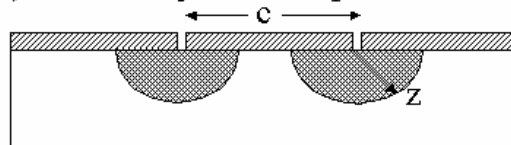

$$Q_{\text{covered}}/Q_{\text{uncovered}} = (\pi/2c) \cdot (t/m)^{1/2}$$

Figure 1.5

Effect of a defect in a dense coating on the moisture uptake in the concrete slab (Q kg/m²). t is absorption time (s), and m is the resistance to penetration of the water front ($m=t/z^2$ s/m²)

1.3 Internal repair and moisture

By internal repair is meant repair of cracks and other damage occurring inside the structure. Causes of these types of damage might be alkali-silica reaction (ASR), internal frost attack, sulphate attack, or leaching. All of these damage types are tightly related to the moisture level in the structure; the higher the moisture level, the more severe the attack. Often these types of damage cannot be repaired, since the structure is too deteriorated. If repair is made, it is often done by injection of cracks and holes caused by the attack, or repair is made by external strengthening of the structure by a reinforced concrete or steel “corset”.

In order to obtain long service life of repair of these types of structures it is essential that the moisture level in the structure can be reduced. This can be done by sealing of cracks, but also by other means, like surface coating, application of dense concrete layers on surfaces exposed to free water from outside, and/or hydrophobing treatment of the surface. Besides, measures outside the structure often have to be made, like drainage, etc.

It is hardly possible to quantitatively calculate the service life of these types of repair. However, if the effect of repair on the *permeability* of the structure to aggressive agents like sulphate ions can be estimated, and verified by testing, approximate calculations of the future deterioration rate of these types of damage can be made. The future rate can simply be assumed to be proportional to the permeability. Thus, 50% reduction in permeability might approximately correspond to 50% reduction of the previous destruction rate.

For deterioration *directly caused by water*, like internal frost attack and leaching, some simple calculations can be made on the future deterioration of the repaired structure by a theoretical analysis of the future moisture condition and permeability; see paragraphs 5 and 7.

In many cases it might be that no more reaction can take place since all reactive material has already been used up at the time of repair. Then, service life of the repair is reduced to the service life of the repair material itself. This can be the case for ASR, and for sulphate attack. In these cases the moisture level plays no role.

The required evaluation of the durability of repair materials must be based on testing of the materials in relevant environments (UV-radiation, moisture variation, temperature variation, etc.) Durability of bond between the old concrete and repair material must also be evaluated, see paragraph 11.

As shown above, service life evaluation of structures repaired for internal damage relates on data for permeability of the repaired structure. Such data are unfortunately not always available at the time of selection of repair methods. Therefore, the calculation has to be based on collection of data from previously repaired structures.

1.4 Methods of analysing moisture in a repaired structure

A general discussion of theories for moisture transport and fixation in porous materials is carried out in APPENDIX 1. Practical methods for calculating moisture in materials are also given in that reference. Many important destruction mechanisms require very high moisture levels, sometimes above “the hygroscopic range” (>98% RH) -like ASR-, and in some cases also above the “capillary range” (absorption in air voids, compaction pores, cracks and defects) -like frost damage.

In APPENDIX 1 it is shown that it is difficult to calculate moisture transport at such high moisture conditions, primarily because material data are lacking. Therefore, it is also difficult to analyse the effect of repair on the moisture condition at interface zones between old concrete and repair material. One should therefore consider making lab-tests simulating real conditions in order to find out which moisture conditions might be expected in the repaired structure. Such lab-tests can suitably be combined with durability tests, like tests of frost resistance.

For repair materials based on OPC material data given in paragraphs 15.2-15.5 can be used for estimates of moisture transport and moisture uptake. For other materials moisture data have to be determined experimentally. Reference to test methods are given in paragraph 14.

2 REPAIR OF STRUCTURES ALREADY DAMAGED BY REINFORCEMENT CORROSION

2.1 General repair principles

A common method to restore a structure with ongoing reinforcement corrosion is to replace the old carbonated or chloride infected concrete cover by a new concrete cover. This will often substantially prolong service life since corrosion is effectively stopped for long time until the new cover is carbonated, or chloride infected to an unacceptable degree.

Another possibility is to apply a dense surface polymer-based layer (coating), or an additional concrete cover above the old cover without removing this. Such surface layers will affect the inner moisture state as described above, but they will also affect the rate of penetration of carbon dioxide, oxygen and chloride into the old concrete. They will not stop ongoing corrosion, however. Different materials for surface coating are more or less permeable. The net effect of the surface layer might therefore be a reduction in the corrosion rate, increasing the residual service life after repair, but it might also be an increase in the corrosion rate. The net effect of different repair systems on the future corrosion and service life must be evaluated. Effects of cracks in the repair material must thereby be considered. In a structure with ongoing corrosion there are often bars or parts of bars that have not yet started to corrode. The surface layer might retard start of corrosion in such bars.

2.2 Application of a coating or concrete layer on top of the old cover

Application of a defect-free dense surface coating, or an additional cement-based cover *on top of the old cover* (A and B in Figure 2.1), might be used in cases where the corrosion depth is not so big that structural stability is jeopardized. Such repair will not stop corrosion, however, since active corrosion is already going on. Therefore, the additional service life of such a repair will be marginal. It might just retard the corrosion rate by reducing the moisture level in the concrete. Thereby the service life can be somewhat prolonged. Also a hydrophobing treatment of the surface will sometimes reduce the internal moisture content reducing corrosion rate. Surface layers may also slow down further ingress of chloride and oxygen which might give a certain, but very uncertain, reduction in the rate of corrosion. If the polymer coating cracks, corrosion rate will probably not be significantly reduced.

There is, however, a theoretical possibility that an additional cement-based cover on top of the old cover can act as protection by furnishing alkali ions to the old cover and by absorbing chloride. Thus, it might be that corrosion will cease for some time until also the additional cover is carbonated or infected by chloride. Cement with high slag content might be more effective chloride absorbing material than traditional OPC-concrete. The real importance of such re-alkalisation and chloride absorbing effect has, however, not been enough verified experimentally.

If a dense polymer coating is used, moisture accumulation in the old concrete might occur, which might negatively affect its frost resistance.

2.3 Replacing the old cover by polymer-based cover

Replacing the old cover by a new *polymer-based cover* (C in Figure 2.1) will stop corrosion provided the cover is *completely impermeable* to chloride ions and carbon dioxide. Cracks in the cover will, like cracks in polymer-based coatings, cause continued corrosion. Therefore, for safety reasons and when long service life is required, these types of repair should be avoided on structures in which corrosion is already going on. They can only be made for “cosmetic repair” lasting only a few years.

In cold climate moisture accumulation in the old concrete might occur, which might negatively affect its frost resistance.

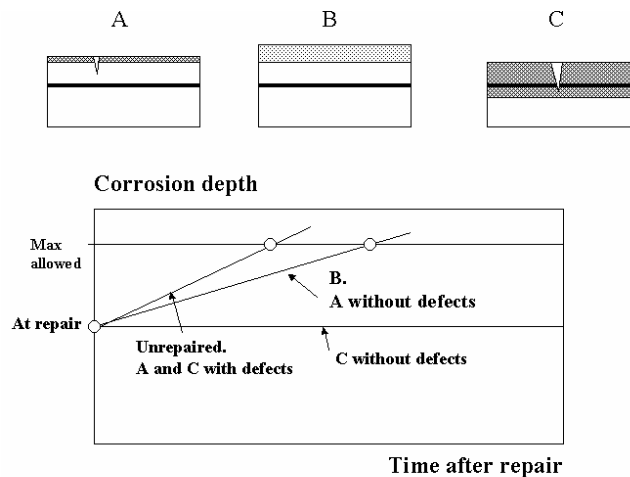

Figure 2.1

Different (less suitable) possibilities of repairing a structure with ongoing reinforcement corrosion. A: Dense surface coating on intact cover. B: Additional concrete cover on intact cover. C: New cover based on polymer.

2.4 Replacing the old cover by cement-based cover

Replacing the old cover by *a new cement-based cover* might effectively stop corrosion; see Figure 2.2. The service life is depending on how fast carbonation in the new cover can occur, and on the effective permeability of chloride ions. The most simple (and most pessimistic) approach is to assume that the penetration rate of the carbonation front, and the chloride threshold front in the new cover, are proportional to the square-root of time.

$$x = D \cdot t^{1/2} \quad (2.1)$$

The proportionality constant D (a measure of the effective diffusivity) of carbon dioxide and chloride ions depend on the chemical and physical composition of the cover. It also depends on the outer CO_2 -concentration and chloride concentration.

For safety reasons the service life is supposed to be ended when the carbonation front, or the chloride threshold concentration, reaches the reinforcement, i.e. when $x = C$ where C is the thickness of the new cover. Thus, the service life of the repaired structure is

$$t_{\text{life}} = (C/D)^2 \quad (2.2)$$

The coefficient D must be based on testing of the actual repair material, or taken from general information on diffusion coefficients of carbon dioxide and chloride ions for different types of concrete. For *carbonation* data from Figure 3.3 can be used in estimating the value of D . For *chloride transport* data in Table 15.2 might be used for concrete, in case data for the actual material is lacking (Note: D in equation (2.3) is not exactly the same as δ_{eff} in Table 15.2. The interrelation between the two values is given by Fick's law, equation (15.13)) The experimental determination of D must be made at *moisture levels* in the material that are relevant for the practical use of this.

The threshold concentration of chloride is not very well known. Data used for service life prediction of new structures might be used, although they are very uncertain. Some data are given in Table 15.3.

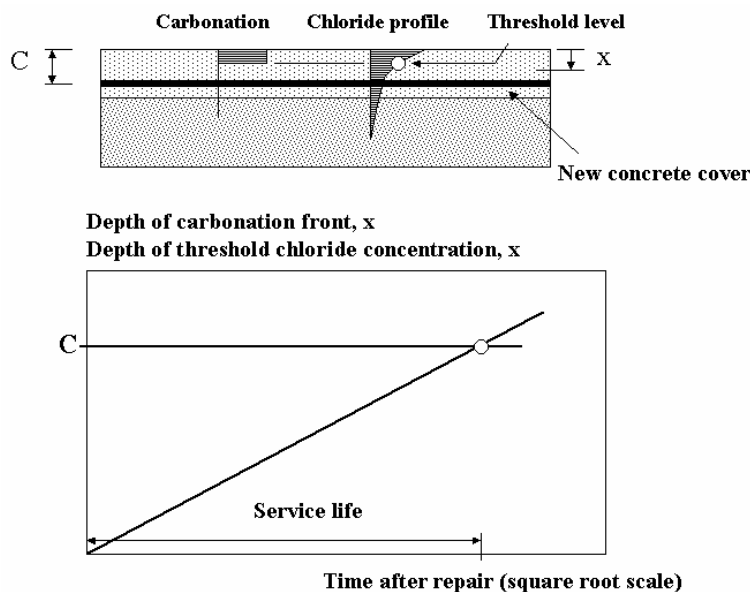

Figure 2.2

Replacement of cover over corroding reinforcement by new cement-based cover. Service life is ended when $x=C$. (For safety reasons, the corrosion stage is not included in service life.)

Different types of structures (parking decks, bridges, façades, hydraulic structures, etc.) in different types of climate will behave differently after repair by new concrete cover, since the effect of a certain repair can be different for different structures due to different boundary conditions, like different geometry and climatic conditions (moisture, temperature, CO_2 -level, chloride load). An analysis of the future penetration must be made in each individual case.

2.5 Chemical and electro-chemical methods

Other possibilities to stop corrosion are *re-alkalisation* of the carbonated cover, or *forcing chloride out* by applying an electrical field. Such methods have to be analysed very carefully before they are applied so that one can be sure that they actually works. Also the long-term effect has to be analysed so that one does not risk that corrosion re-starts too short time after the repair was done. Methods for such analyses have to be developed. No quantitative service life calculations can be made on the basis of present knowledge.

Another possibility to stop corrosion is to apply *cathodic protection*. This is a long-lasting technique since it will work as long as the reinforcing steel is maintained cathode in an electric cell. Cathodic protection can be risky in cases where the same steel is located in many different inner concrete environments, with different ion concentration, different moisture levels, etc.

Chemical substances acting as *inhibitors* must be evaluated with regard to short-term and long-term effects for different structures exposed to different environments, and being in different status as regards corrosion when the inhibitor was applied. One cannot exclude that the inhibitors are leached out of the concrete in some types of environment. There are no possibilities today to evaluate the service life at use of such chemical methods.

3 REPAIR FOR PROLONGING TIME UNTIL ONSET OF REINFORCEMENT CORROSION

3.1 Basic principles

For structures in which corrosion has not yet started, a repair material put on top of the surface of the concrete might substantially increase the residual incubation time before start of corrosion, provided the material is sufficiently dense to carbon dioxide and chloride (like dense polymer coatings), or provided the material is chloride or carbon dioxide absorbing (like cement mortar or concrete).

The function of different types of protective layer is illustrated in Figure 3.1.

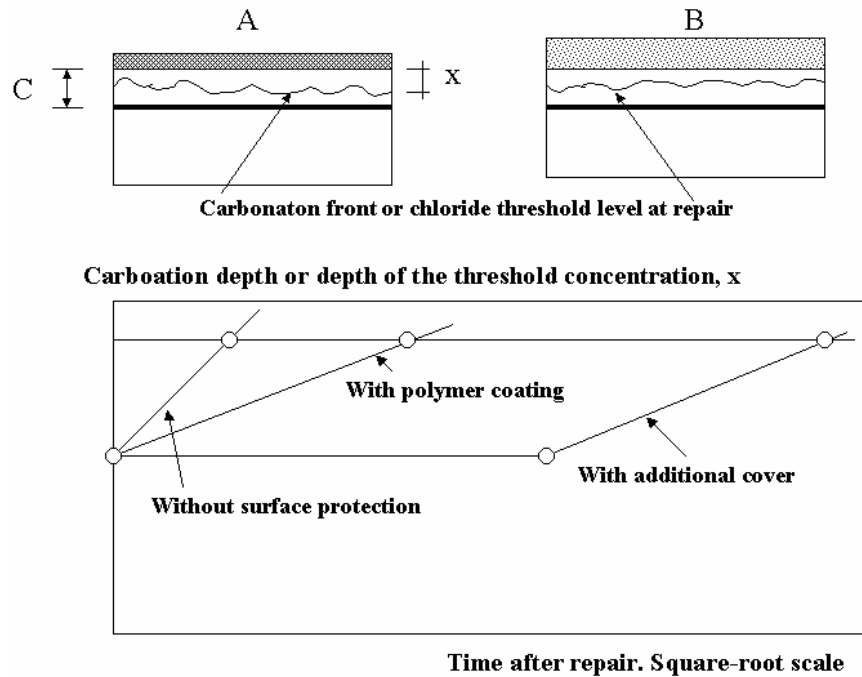

Figure 3.1: Different possibilities to prolong the time until start of reinforcement corrosion.
A: Dense polymer coating. B: Additional cover of cement mortar or concrete.

3.2 Effect of a dense polymer-based coating on further carbonation

The effect of a dense, defect-free, non-absorbing coating (A in Figure 3.1) on the service life with regard to *carbonation* can be evaluated by the following equation.

$$\Delta t_{\text{coated}} = \Delta t_{\text{uncoated}} \left\{ 1 + \left[\frac{(2\delta_b \cdot h)}{(\delta_1 \cdot T)} \right] \cdot \left[\frac{1}{(1+\alpha)} \right] \right\} \quad (3.1)$$

$\Delta t_{\text{uncoated}}$ is the residual service life of the unrepaired concrete (s)

Δt_{coated} is the service life of the repaired concrete (s)

δ_b is the effective diffusivity to carbon dioxide of the carbonated concrete (m^2/s)

h is the thickness of the coating (m)

δ_1 is the effective diffusivity of the coating to carbon dioxide (m^2/s)

T is the concrete cover (m)

α is the fraction of the cover that is carbonated when repair is made (-)

The second term on the right side of the equation describes the effect of the coating.

The residual service life of the *uncoated* concrete is obtained from equation (2.1):

$$\Delta t_{\text{uncoated}} = t_0 [(1/\alpha)^2 - 1] \quad (3.2)$$

t_0 is the age of the structure when coating is applied

Equation (3.1) is plotted in Figure 3.2 for the cover 25 mm. The required data for carbonation depth and diffusivity of concrete can be obtained from investigations on the damaged structure. The diffusivity of the coating must be determined by testing.

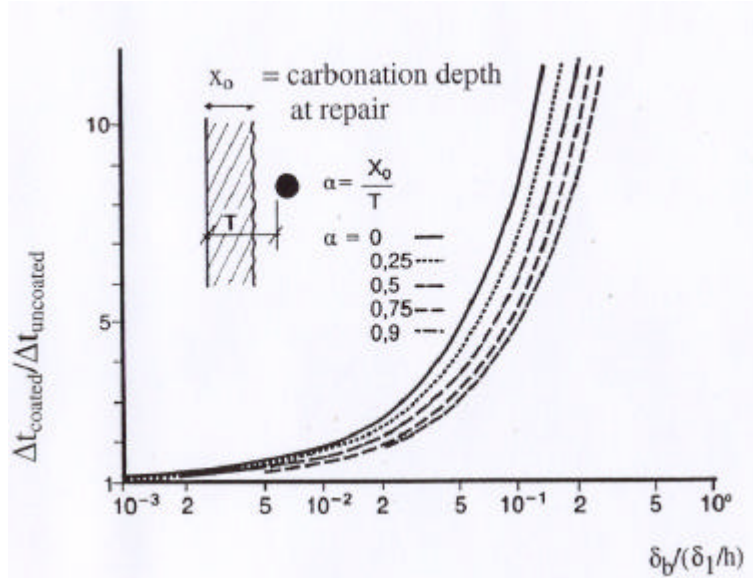

Figure 3.2
Plot of equation (3.1) for 25 mm cover.

Example:

A concrete with 30 mm cover is carbonated to the depth 25 mm ($\alpha=25/30=0.83$) after 25 years ($7.9 \cdot 10^8$ s). The CO_2 -diffusivity of the carbonated concrete is supposed to be 10^{-9} m²/s.

A coating is applied with permeability to CO_2 that is $\delta_1=6 \cdot 10^{-11}$ m²/s and thickness 5 mm.

This means that the CO_2 -resistance of the coating corresponds to 8.3 cm carbonated concrete.

The residual service life if no coating is applied is: $\Delta t_{\text{uncoated}}=25[(1/0.83)^2-1] = \mathbf{11 \text{ years}}$

The residual service life after application of the coating is according to equation (3.1):

$$\Delta t_{\text{coated}}=11\{1+[2 \cdot 10^{-9} \cdot 0.005/(6 \cdot 10^{-11} \cdot 0.03)][1/(1+0.83)]\}=\mathbf{44 \text{ years}}$$

In equation (3.1) it is assumed that the diffusivity of the concrete cover is not changed after application of the cover. Probably, however, some changes in the moisture level occur, which influences the diffusivity of the sub-base concrete. This can be considered by the following changes in the equation.

$$\Delta t_{\text{coated}} = \Delta t_{\text{uncoated}} \{ \delta_{b,\text{before}} / \delta_{b,\text{after}} + [(2\delta_{b,\text{before}} \cdot h) / (\delta_c \cdot C)] \cdot [1 / (1 + \alpha)] \} \quad (3.3)$$

where

$\delta_{b,\text{before}}$ is the diffusivity of the substrate concrete before repair

$\delta_{b,\text{after}}$ is the diffusivity of the substrate concrete after repair.

The value of δ_b can be estimated from the carbonation depth before application of the new surface layer:

$$\delta_b = (x_0^2 / t_0) \cdot M / (2 \cdot c_0) \quad (3.4)$$

x_0 is the carbonation depth when the new surface layer is applied (m)
 t_0 is the age of the concrete when the new surface layer is applied (s)
 M is the amount of material able to carbonate (mole/m³)
 c_0 is the outer concentration of CO₂ (mole/m³)

3.3 Effect of a dense coating on further chloride penetration

The effect of a coating (non-chloride absorbing) on the *chloride penetration* can be calculated by the diffusion equation (3.5), using the new boundary condition at the interface between concrete and repair material, equation (3.6). Thus, the surface layer is treated as a constant surface resistance in the solution to the diffusion equation.

$$dc/dt = \delta_{b,eff} \cdot d^2c/dx^2 \quad (3.5)$$

$$(dc/dx)_{x=0} = (c_1 - c_{interface}) \delta_c / (h \cdot \delta_{b,eff}) \quad (3.6)$$

c is the concentration of free chloride (mole/m³)
 $\delta_{b,eff}$ is the effective diffusion coefficient of free chloride in concrete, considering the retarding effect of chloride binding (m²/s)
 δ_c is the chloride diffusion coefficient of the coating (m²/s)
 $c_{interface}$ is the concentration of free chloride at the interface between concrete and repair material (mole/m³). It is considered to be constant.
 c_1 is the “driving” outer concentration of free chloride (mole/m³)
 h is the thickness of the coating (m)
 x is counted from the interface between concrete and coating (m)

These equations can be solved numerically. Input is the actual free chloride profile in the old concrete at repair. Besides, information on the chloride diffusivity and chloride binding of concrete and coating are required. The former is obtained from the measured chloride profile in the old concrete. The latter must be determined by testing. Normally, however, binding of chloride in a polymer coating can be neglected.

Free chloride is used in the equation and not total chloride (total=free+bound). It is not possible, technically, to determine free chloride profiles in concrete. The free chloride profile can be approximately determined from the total chloride profile using information on relation between free and bound chloride (the “chloride binding isotherm”). Some information on binding isotherms can be found in [5] and [15].

3.4 Effect of an additional concrete cover on further carbonation

When the concrete is covered by an additional concrete cover (B in Figure 2.1) the carbonation of the old cover stops until the new cover is completely carbonated. Thereafter, the continued carbonation is slowed down, compared to the rate before repair, due to the thicker cover. If the new cover is of high quality, and fairly thick, the service life of the repaired concrete will be very long. Carbonation of the new cover will be governed by the following equation:

$$x = C_c \cdot t^{1/2} \quad (3.7)$$

x is the depth of the carbonation front in the new cover (m)

C_c is a material coefficient for the new cover, including the effective diffusivity of carbon dioxide and the outer concentration of CO_2 ($m/s^{1/2}$); see equation (15.12).

t is time after application of the cover (s)

When the coefficient C_c is known, the time until the new cover is carbonated which corresponds to onset of new carbonation of the old concrete can be calculated; cf. equation (2.2):

$$t_1 = (h/C_c)^2 \quad (3.8)$$

where h is the thickness of the new cover (m)

Instead of calculating the time for the new cover to carbonate one can use known values of carbonation for normal concrete. Examples of carbonation as function of time for OPC-concrete in two “type environments” are shown in Figure 3.3; [5].

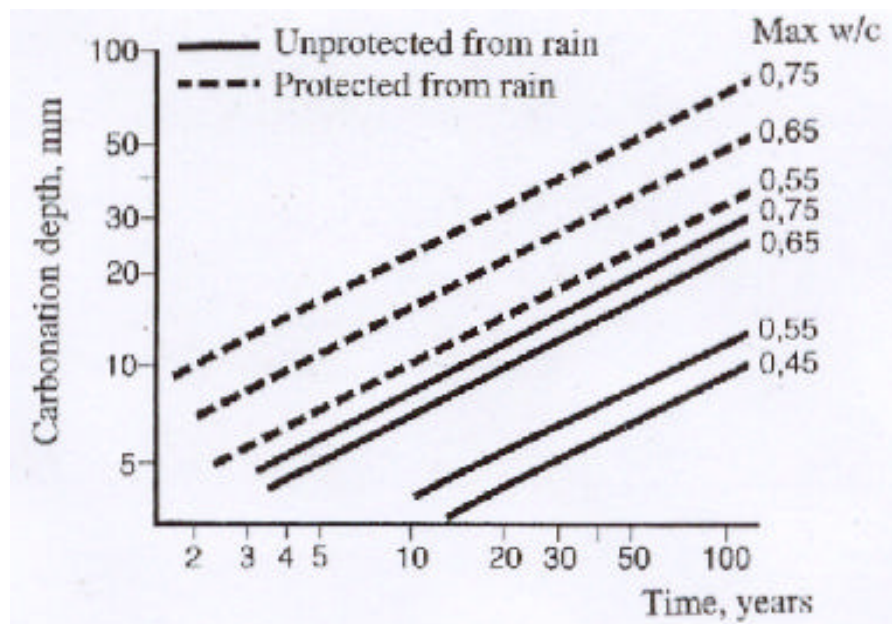

Figure 3.3

Maximum carbonation depth of OPC-concrete exposed to two different types of environment, [5].

Example:

If the additional cover is 30 mm and the w/c-ratio is 0,50 it will take at least 80 years before carbonation of the old cover continues. In a more moist environment, the time is much longer.

When carbonation starts again in the old concrete the rate will be reduced due to the additional cover. Equation (3.1) can be used for calculating service life if δ_c is the carbon dioxide diffusivity of the carbonated additional concrete layer, and h the thickness of this layer.

3.5 Effect of an additional concrete cover on further chloride penetration

When the concrete is exposed to *chloride*, the service life calculation of case B in Figure 2.1 is more complex. For long time after application of the additional cover, no more chloride can enter the old cover since all chloride is taken up in the new cover. The chloride existing in the old cover at repair will instead be re-distributed. Some chloride will be absorbed in the new cover, and some will move inwards in the old concrete. It might therefore take much longer time for corrosion to start than if no cover was added. By using a highly chloride absorbing concrete as additional cover (like concrete based on slag cement with high slag content), there might be so big reduction of the chloride level in the old concrete that the service life of the repaired structure becomes very long. The principles are shown in Figure 3.4.

Exactly what happens after application of the additional cover can be calculated by numerically solving the general transport equation for ion transport, equation (3.5). Information needed is the chloride profile in the old concrete, chloride absorptive (binding) properties of old and new concrete, and chloride diffusivities of these. Test methods for chloride absorption and chloride diffusion for the new concrete layer have to be used. For the old concrete, information can be obtained by testing the chloride profile in the structure.

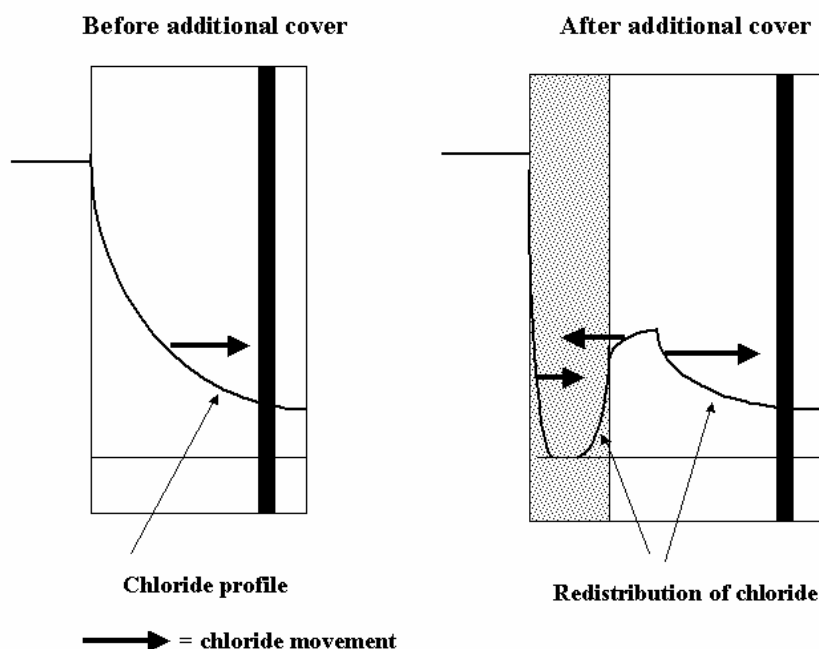

Figure 3.4

Chloride redistribution after application of an additional concrete cover. Principles

3.6 Additional information

The effect of repair on *carbonation* of the repaired structure is further discussed in APPENDIX 2. The effect of repair on *chloride transport* of the repaired structure is discussed in APPENDIX 3.

Both these references also contain equations for a theoretical analysis of the service life of concrete repaired by an additional concrete cover.

4 REPAIR OF STRUCTURES AFFECTED BY ASR

A rapid progress of ASR requires high moisture level in the structural member (90-100% RH). After repair, changes in the inner moisture level can be expected for certain repair systems, like thick and dense surface repair layers, or crack sealing. The effect on ASR might be positive if the moisture level is substantially decreased due to hindered water absorption, but it is probably negative if the moisture level is increased due to hindered evaporation. As said in paragraph 1.3 it is not possible to calculate quantitatively, in a safe way, the effect of repair on the inner moisture condition. Therefore, it is not possible to evaluate in a safe way the service life of a repaired ASR-damaged structure.

Even if it is not possible to reduce the internal moisture content to levels where ASR is no longer possible, it might be that more or less all reactive material has been consumed before repair is made. In this case no further damage can occur after repair.

A typical destruction curve is shown in Figure 4.1. It has an S-shaped form. After some years destruction is retarded due to lack of reactants (alkali hydroxide and/or alkali-soluble silica). Methods of assessing the actual degree of ASR reaction and the potential future expansion are given in [6b].

If a stage with small potential future reaction has been reached before repair is made, the assessment of the future service life is more or less restricted to the assessment of the service life of the repair material itself, and to the assessment of the time-dependent effect of the repair on the future expansion of the structure. Strengthening procedures can then be undertaken in order to cope with this expansion so that the required service life is obtained. Thus, service life assessment is often restricted to an assessment of the required strengthening measures.

For structures that are also exposed to frost, the possible negative effect on the frost resistance caused by moisture accumulation under dense surface layers, or due to other strengthening measures, must be analysed.

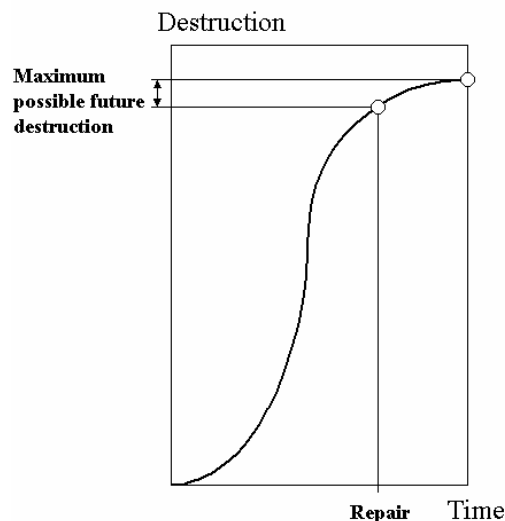

Figure 4.1
Typical destruction curve for ASR.

5 REPAIR OF STRUCTURES AFFECTED BY LEACHING

In many cases, a leached structure has reduced strength and reduced structural stability. Experimental investigations between degree of leaching and loss of strength and stability are presented in [7]. Repair can either be a fairly simple surface sealing stopping further leaching, or be an injection (restoration) of the leached inner part of the structure.

Leaching by percolating water is directly proportional to the leaching rate, i.e. to the permeability to water under pressure. If permeability is reduced by repair, water flow will reduce, and consequently, the future leaching can be calculated. Methods for analysing the future deterioration caused by leaching are presented in [6d]. If no repair is made the future leaching can be described by:

$$Q_v \cdot L = q_{v,o} \cdot s \cdot (t^2/t_0 - t) + Q_{v,o} \cdot L [2(t/t_0) - (t/t_0)^2] \quad (5.1)$$

The equation is based on the assumption that permeability is increased linearly with time due to continued leaching. This is a bit optimistic assumption, since in reality, permeability ought to increase more rapidly because permeability can be suspected to grow progressively with leaching. Expressions for other time processes of permeability growth are given in [6d].

After repair, the permeability of the structure, valid when repair is made, is reduced by a factor β and is supposed to be kept constant afterwards. Then, the future leaching is described by:

$$Q_v = Q_{v,o} + \beta \cdot s \cdot (t - t_0) q_{w,o} / L \quad (5.2)$$

where

Q_v is the total amount of leached lime from erection of the structure (kg lime/m³ concrete)

$Q_{v,o}$ is total leaching at time of repair (kg lime/m³ concrete)

L is the thickness of the structure in the direction of water flow (m)

$q_{w,o}$ is the water flow at repair (kg water/m²·s)

t is time from erection of the structure (s)

t_0 is age of the structure at repair (s)

s is the water solubility of lime in percolating water (kg lime/kg water)

By comparing the two equations (5.1) and (5.2) the service life effect of repair can be evaluated. The only information needed is the amount of leaching when repair is made, the water flux when repair is made, the concentration of lime in percolating water, and the reduction in permeability caused by repair.

Example

A 2 m thick structure is 30 years when it is repaired. The total amount of dissolved lime is 20 kg/m². The lime concentration in percolating water is 1.6 g/litre (almost saturated), and the actual water flux is 0.1 litres per m² and hour.

If the concrete is not repaired, the additional lime lost after 20 years will, according to equation (5.1), be **46 kg/m³**.

If repair is made (e.g. by application of a dense surface), so that permeability is reduced to 50% of what is before repair, the additional loss of lime 20 years after repair will, according to equation (5.2), be only **7 kg/m³**.

Leaching causes strength loss of the structure. This can be described by, see [6d]:

$$\Delta f/f_0 = 1 - (1 - \Delta X/X_0)^3 \quad (5.3)$$

where

Δf is the loss in strength of the cement paste phase due to leaching

f_0 is the initial strength of the cement paste

X_0 is the volume of load-carrying substance in the cement paste (m^3/m^3)

ΔX is the loss in load-carrying substance due to leaching (m^3/m^3)

This equation shows that if 20% of the initial load-carrying phase is lost, the strength reduction of the cement paste might be 50%. The strength loss of concrete is of the same order of size.

The calculated leaching in kg/m^3 can be transformed to volume, using the density of the leached substance.

It is not quite clear what is meant by load-carrying phase in equation (5.3). It might be all lime-containing phases in the concrete. Or, it may be that the most soluble substance, calcium hydroxide, shall be excluded. In the latter case, substantial leaching can occur without loss of strength. Observations indicate, however, that all lime leaching, also leaching of $\text{Ca}(\text{OH})_2$, causes loss of strength.

A service life evaluation of a repair method for structures exposed to leaching is often reduced to an evaluation of the long-term durability of materials used for reducing moisture flow, like injection and surface protection layers. Methods for testing deterioration of such materials must be used as input in the assessment.

For structures that are also exposed to frost, the effect on frost resistance of moisture accumulation under dense surface layers must be analysed.

Application of watertight surface layers and injections might change the water pressure profile across structures exposed to one-sided water pressure (like dams). Thereby the stability of the structure (the safety to overturning) can be jeopardized. This must be considered. Principles are shown in [6d].

6 REPAIR OF STRUCTURES AFFECTED BY SALT-FROST EROSION

Combined salt and frost load might cause erosion of the concrete surface. Erosion might be stopped by application of a salt-frost resistant surface layer. Different types of surface layer will have different ability to protect, and must, therefore, be evaluated by some sort of performance test.

One possibility is to use a salt-frost scaling test of the repair material. A suitable method is the Swedish test method, [10]. In this, the scaling is measured during accelerated frost testing in 3% NaCl-solution down to -20°C . 56 or 112 daily freeze/thaw cycles are used. Scaling as function of time is measured. Scaling in the real environment can be assessed by the following extrapolation, [6c]:

$$d = [S_N \cdot N_{\text{equivalent}} / (\gamma \cdot N)] \cdot t \quad (6.1)$$

d is the scaling depth after t years (m)

S_N is the total weight of scaling in the test specimen after terminated test (N cycles) (kg/m^2)

N is the total number of cycles used in the freeze/thaw test (-)

$N_{\text{equivalent}}$ is the yearly number of freeze/thaw cycles in practice of the same severity as the cycle used in the test (cycles/year)

γ is the density of the scaled material (kg/m^3) (about 2000 for concrete)

t real time (years)

In order to transform the real freeze/thaw cycles to equivalent number of cycles in the test, the following damage relation might be used:

$$S = \text{const} \cdot \theta_{\min}^2 \quad (6.2)$$

Where S is the estimated scaling and θ_{\min} is the minimum temperature during freezing.

Using this relation, the really occurring freeze/thaw cycles in practice during a year can be transformed to a number of equivalent freeze/thaw cycles in a test:

$$N_{\text{equivalent}} = \sum N_i (\theta_i / \theta_{\text{ref}})^2 \quad (13)$$

Where

N_i is the number of cycles during a year with minimum temperature θ_i

θ_{ref} is the minimum temperature used in the test, normally -20°C .

Thus, by using data from a freeze/thaw test of the repair material, and a criterion for the maximum allowed scaling depth, the service life of repair with regard to salt frost scaling can be estimated.

A potential risk is that moisture is accumulated between the old concrete and the new denser surface layer. This might cause frost damage in the old concrete due to *internal* frost action. The risk for this to take place increases if the surface layer is defect by cracking. One possibility to test this risk is to use freeze-thaw tests of the entire repair system; sub-base concrete+repair material. Suitable test methods are described and applied in [4]; figure 11.2.

7 REPAIR OF STRUCTURES AFFECTED BY INNER FROST DAMAGE

This case resembles structures affected by ASR. Increase in the inner moisture condition after repair will inevitably increase the rate of damage. Reduction in the moisture condition will be very favourable and retard, or even stop, further degradation. What happens depends on the outer conditions, the availability of moisture from outside, the geometry of the structure, the quality of the old concrete, and the type of repair material. Different situations have to be analysed.

Probable future destruction of the old structure after repair is illustrated in Figure 7.1. The theoretical background is given in [6c].

- *Curve A* is valid for a case (a moderately wet environment, like a facade) where no moisture accumulation occurs, and where destruction has stopped years before repair is made. Repair is therefore only necessary if the function of the structure is regarded too low. Repair is made by a technique that will not cause an increase in the inner moisture condition in the old concrete, like casting a new concrete envelope around the structure, and/or injecting cracks. Therefore, no further frost damage will occur in the old concrete. The service life of the repaired structure will depend on the durability of the material used for repair. If this is very high, the future damage of the repaired structure can be described by:

$$D(t) = D(o) \quad (7.1)$$

In which $D(t)$ is damage in the old repaired concrete after time t counted from erection of the structure, and $D(o)$ is damage in the old concrete when repair is made. Damage D might be reduction in one or more of the following mechanical properties; compressive strength, tensile strength, bond strength, E-modulus. Reductions that can be expected are described in [6c]

- *Curve B* is valid for a case (wet environment, like a hydraulic structure periodically exposed to water) where a certain moisture increase might occur in the old concrete during wet periods, but where certain drying periods occur. Drying is, however, somewhat smaller than absorption. Therefore, a certain gradual accumulation occurs, which might cause some further destruction in the repaired structure. This destruction can be described by:

$$D(t) = D(o) \cdot (t/t_0)^{1/2} \quad (7.2)$$

Where t_0 is the age of the structure when repair is made and t is the age of the repaired structure. It is assumed that the same moisture absorption rate occurs after repair as before.

- *Curve C* is valid for a case (constantly wet environment, like a column in or directly above the water surface) where no drying is possible. Then, after repair the destruction of the repaired structure can be approximately described by:

$$D(t) = D(o) \cdot (t/t_0) \quad (7.3)$$

The forces developed by frost in a structure with moisture level above the critical are so big that no repair system can really cope with them. Therefore, a long service life of a structure

damaged by internal frost, and where the structure is placed in a very wet environment, can only function for long time if moisture uptake can be effectively stopped by repair, Curve A. Relations between moisture level and frost resistance are further discussed in [6c].

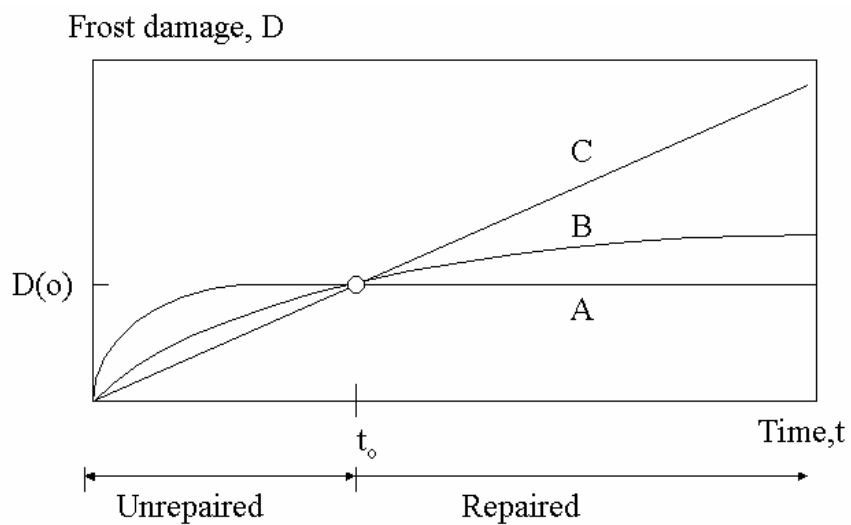

Figure 7.1
Frost destruction curves before and after repair, [6c].

8 REPAIR OF STRUCTURES AFFECTED BY EROSION SURFACE ATTACK

A surface damaged by erosion is normally repaired by application of an erosive-resistant surface layer, either cement-based or polymer-based. The service life of the repaired structure will depend on the erosion resistance of the new surface. This can be estimated by wear tests of the material. Unfortunately there is low correlation between erosion in the test and erosion in reality. Besides, the time-axis in the test, i.e. the transformation of time in the test and the real time in practice, is unsafe. Therefore, it is not possible to make any safe service life calculations. The material that behaves best in the test should, however, normally be selected.

9 REPAIR OF STRUCTURES AFFECTED BY ACID ATTACK

Acid attack is normally located only to the exposed surface of the concrete. Calcium-based components in this might have become more or less totally dissolved to a certain depth. The remaining material is porous and weak. Repair consists of removal of all attacked concrete to a depth where there is sound concrete. A new acid-resistant layer, normally polymer-based, is applied. The service life can be estimated from tests of the acid resistance of the repair material. If accelerated testing is used, it might be difficult to transform measured resistance to real destruction in the field. Therefore, acceleration during the test should be as mild as possible.

If the coating is not perfectly tight against acid penetration, destruction of the old concrete might continue, although by a reduced rate which is approximately proportional to the acid permeability of the coating. The process after application of the new coating can be described by the following equation (it is assumed that all attacked concrete to depth x_0 is removed before application of the coating):

$$x^2 + (\delta_b/\delta_1) \cdot 2 \cdot h \cdot x = (x_0^2/t_0) \cdot t \quad (9.1)$$

Where

x is the destruction depth below the coating after time t counted from application of the coating (m)

x_0 is the destruction depth before application of the coating (m) (Removed before the coating is applied)

t is the exposure time counted from application of the coating (s)

t_0 is the exposure time (concrete age) when coating is applied (s)

δ_b is the effective diffusivity of acid in attacked concrete (m^2/s)

h is the thickness of the coating (m)

δ_1 is the effective diffusivity of the coating to the acid (m^2/s)

The diffusivity of the concrete can be estimated from the attack depth before application of the cover:

$$\delta_b = (x_0^2/t_0) \cdot (a/m) \cdot M/(2c_0) \quad (9.2)$$

Where

M is the amount of reacting (dissolvable) material ($mole/m^3$)

c_0 is the outer concentration of acid ($mole/m^3$)

a and m are the number of moles participating in the dissolution reaction:



where

a , m and r are number of moles reacting (a and m) and formed r

A is the chemical formula of the acid

M is the chemical formula of the material attacked

R is the chemical formula of the products formed (dissolved)

In the equation it is assumed that all reaction occurs inside the concrete at a reaction front, i.e. the acid penetration is the rate-determining factor.

10 DURABILITY OF THE REPAIR MATERIAL ITSELF

Many repair and upgrading materials are based on polymers, or contain a big amount of polymers. Examples are epoxy-based mortars, polyester-based mortars, hydrophobing agents, polymer-modified cement mortar and concrete, injection grout, etc. Polymers normally have limited durability when exposed to long-term high moisture levels or aggressive solutions, or when exposed to high pH, or UV-radiation. The service life (long-term protecting ability) of these materials when used on *real structures in real environments* has to be evaluated by relevant testing. Test data are also required for service life calculations of the repaired structure.

Many modern repair materials consist of fibre composite, based on either carbon fibre, or some polymer-based fibre, or glass fibre. The matrix is normally epoxy or polyester. One might question the durability of these materials in the very alkaline environment furnished by moist concrete. Different materials must be evaluated with regard to service life, considering different types of structures and environmental load (UV-radiation, high pH-value, high and varying moisture level, varying temperature, thermal/moisture movements).

Cement-based materials used for repair shall have a composition that is known to give high service life in the actual types of environment. Often, testing is also needed for such materials. One example is when a cement-based material is used as protection against salt-frost scaling. Then a salt-frost scaling test has to be performed. A suitable method is [8].

11 DURABILITY OF BOND BETWEEN OLD CONCRETE AND REPAIR MATERIAL

For most repair/upgrading systems it is vital that the bond between the old concrete and the repair material is excellent, and that it stays so during the required service life. Different repair materials create different bond to different types of concrete. The compatibility between old damaged concrete and repair material must be evaluated. Long-term effects on bond must be analysed, especially the risk of loss of bond due to cyclic differential thermal and moisture movements, and to frost action.

Calculations of stresses due to differential movement, and thereby the risk of loosening can be calculated by numerical methods, provided material data (physical and mechanical) are known. These have to be determined by testing. Consideration must be taken to long-term changes in properties, especially for polymer-based repair materials that are likely to become more brittle with time.

Testing of the effect of temperature cycles

Another possibility is to use accelerated testing of the risk of loss of bond. In Figure 11.1 some results of a laboratory investigation of the risk of loss of bond due to temperature gradients caused by cyclic heating and cooling are shown; [4]. Different types of concrete and polymer coatings were applied to two types of low grade concrete (strength level 15 MPa and 25 MPa). The coated side was exposed to heat from infra-heaters. Each heating/cooling cycle consisted of one hour heating and one hour cooling. The maximum surface temperature was +60C. The average concrete temperature was +20C. Damage was measured by adhesion and speed of sound.

The spread in bond values was quite big. However, in no case was bond totally lost; the reduction in bond strength was normally below 20%. No change in speed of sound was observed for any repair material, which clearly indicates that temperature cycling had caused neither destruction of materials, nor any big destruction of bond.

Testing of the effect of frost action

The risk of loosening of surface repair material due to frost action can be determined by frost tests of the substrate concrete with applied surface material. Methods are described in [4].

Results of freeze-testing of the same material combinations as in Figure 11.1 are shown in Figure 11.2, [4]. The freeze-test was made in a climate chamber in which the specimens were exposed to 217 cycles consisting of freezing in air for 8 hours followed by thawing in air combined with artificial “rain” for 4 hours.

Damage was determined by loss in bond and loss in speed of sound perpendicular to the repair. As shown in Figure 11.2 loss in bond is often big when polymer-based coatings are used. The uncoated concrete behaved much better than the coated indicating that a dense coating might be a destructive factor and not a protective factor. The reason is probably the accumulation of moisture described in paragraph 1.

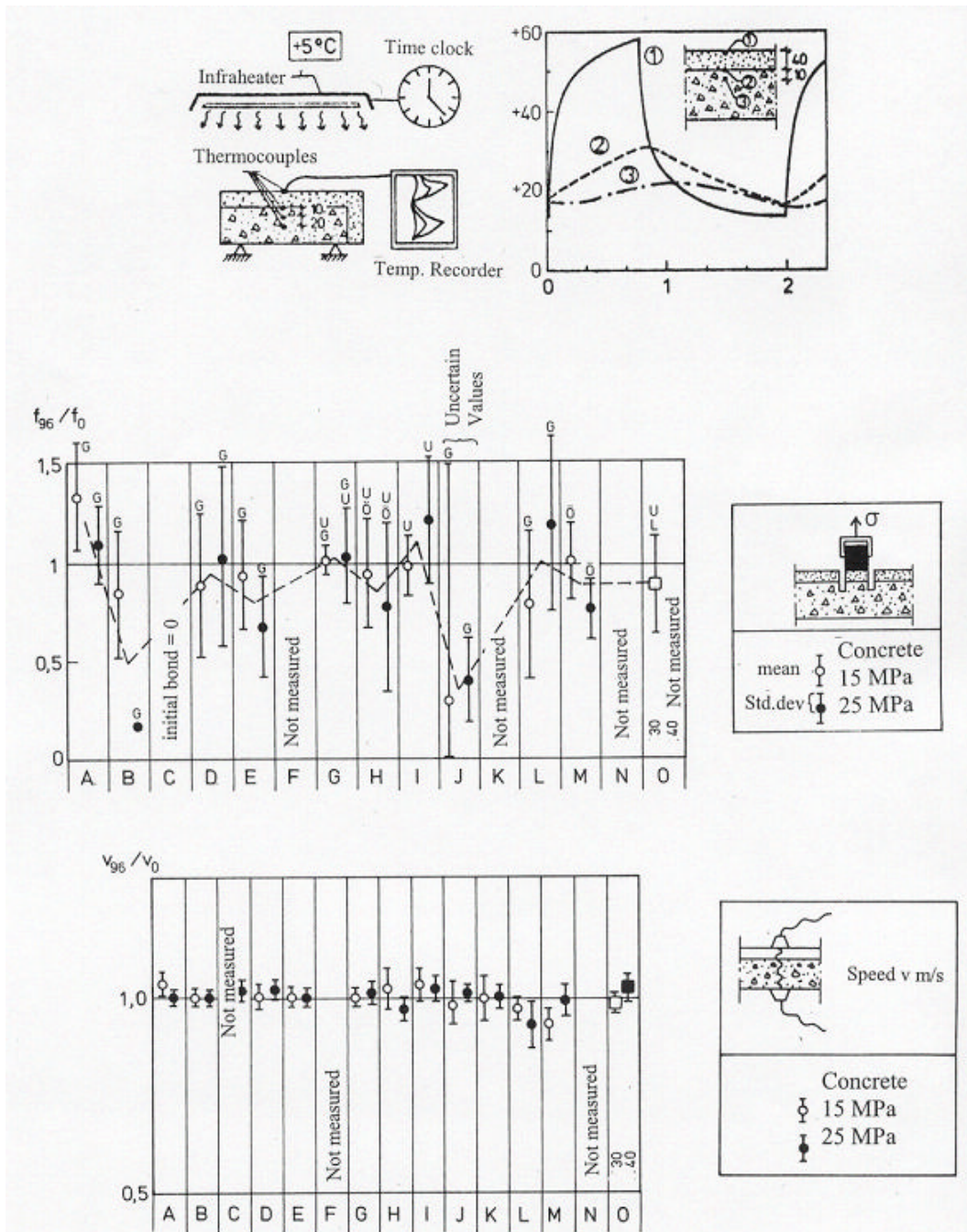

Figure 11.1

Results of an investigation of the effect of 96 temperature cycles on the bond; [4]. (a) The temperature cycle. (b) Residual relative bond strength. (c) Residual relative speed of sound.

A, B: 35 mm cement mortar. C: polymer-modified mortar (initial bond zero). D-J: different polymer coatings (1 to 8 mm thick). K: Silicon treatment. L: glass-fibre reinforced cement mortar. M: cement mortar reinforced by glass fibre fabric. N, O: uncovered (unrepaired) concrete.

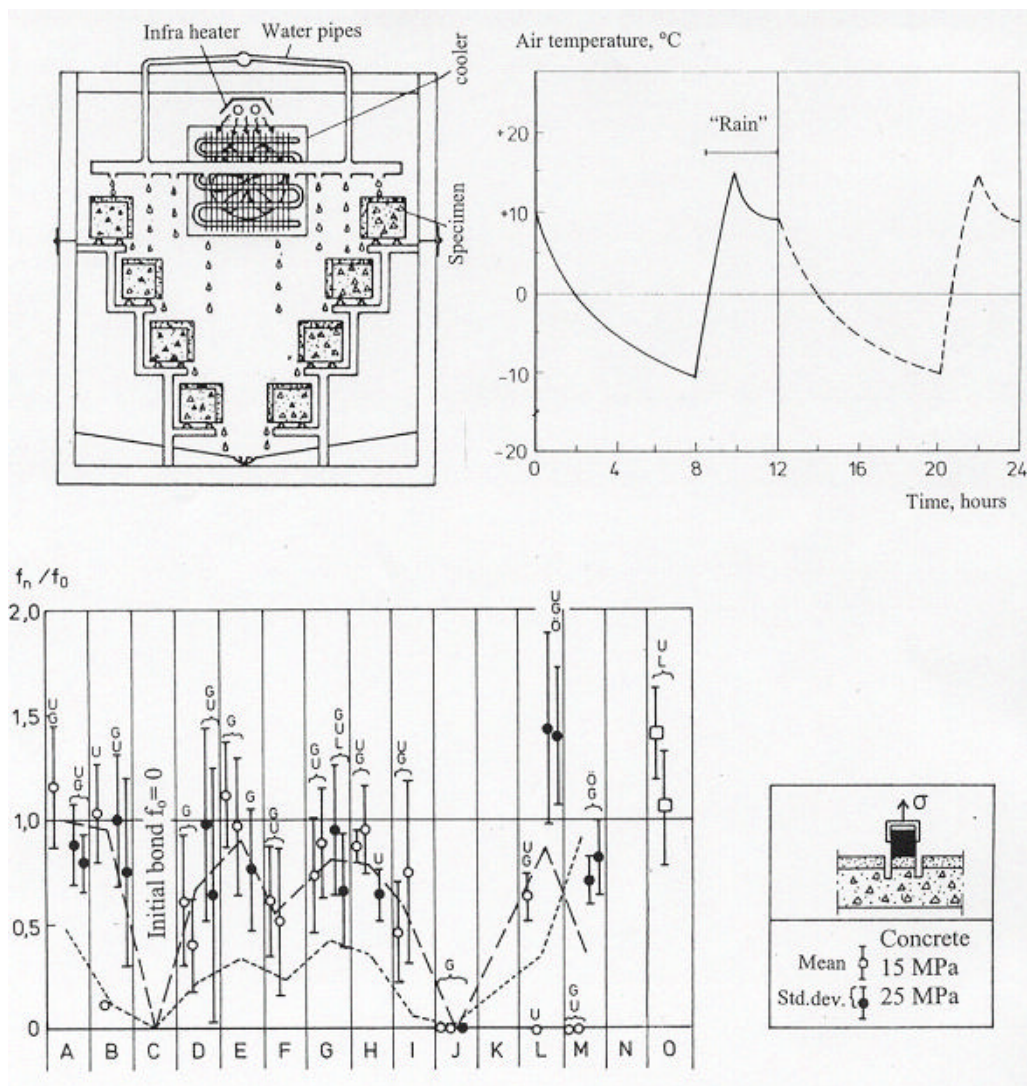

Figure 11.2

Results of an investigation of the effect of 217 freeze/thaw cycles on the bond; [4]. (a) The climate chamber and the freeze/thaw cycle. (b) Residual relative bond strength.

A, B: 35 mm cement mortar. C: polymer-modified mortar (initial bond zero). D-J: different coatings (1 to 8 mm thick). K: Silicon treatment. L: glass-fibre reinforced cement mortar. M: cement mortar reinforced by glass fibre fabric. N, O: uncovered (unrepaired) concrete. (The dotted line shows the results of another type of more severe freeze/thaw).

12 SYNERGISTIC EFFECTS

One type of damage might be strengthened by the simultaneously acting other destruction type. A typical example is when some sort of erosive surface attack is reducing the service life with regard to reinforcement corrosion. There are also other mechanisms involved in synergy.

Examples of potential synergy between frequent damage types are shown in Table 12.1. The table is taken from reference [9] in which different types of synergy are treated theoretically. A numerical example of how to consider synergy between surface erosion and penetration of chloride or carbonation is given in APPENDIX 4.

*Table 12.1: Potential synergistic effects of frost, leaching, reinforcement corrosion and ASR.
+ indicates considerable synergy. – indicates no, or negligible, synergy, [9].*

		Influenced destruction type				
		Internal frost	Salt-frost scaling	Leaching	Corrosion	ASR
Influencing destruction type	Internal frost		-	+	-	-
	Salt-frost scaling	-		-	+	-
	Leaching	+	-		+	-
	Corrosion	-	-	-		-
	ASR	+	-	+	-	

13 TESTS OF REPAIR MATERIALS AND REPAIR SYSTEMS

13.1 Repair materials

It is essential for a proper selection of repair method that repair materials are tested for properties of importance for service life of the repaired structure. Important *material properties* are.

- Permeability to gases (water vapour, oxygen, CO₂), liquids (liquid water, acid water, salt solutions), and ions (chloride ions, sulphate ions). Effect of natural exposure on these properties. By “permeability” is meant transport coefficients for all transport processes; (i) diffusion, (ii) convection, (iii) flow under over-pressure. The effect of chemical/physical binding of the diffused substance is included.
- Durability in natural environment (high pH, UV-radiation, moisture, sea water, freeze/thaw, temperature changes, etc.)
- Thermal coefficient and its change with exposure time
- Stiffness and brittleness and their change with time
- Strength and its change with time
- Chloride threshold value for corrosion

There are numerous standardised test methods for most of these properties and also for additional properties. Most of these methods are, however, applied to the virgin material, before ageing. Moreover, in most cases the test is made at moisture levels in the repair material that is not representative for the really occurring moisture condition at the practical application of the material. Therefore, the results of such tests cannot always be used for a proper evaluation. This must be considered when a material is selected. Methods for testing aged materials and for testing at realistic moisture conditions have to be developed.

Data from testing should be furnished by the manufacturer. If data are lacking a reliable service life assessment is not possible.

For some types of pure polymers general data exist, e.g. for alkali resistance, gas permeability, etc. Then, testing is not required. Polymer products used for repair almost always contain additional materials beside the pure polymer. This might affect the properties considerably. Therefore, tests must be made by the manufacturer on such products.

For cement-based materials, fairly good data exist for moisture diffusivity, chloride diffusivity, strength, E-modulus and other properties of importance. Data for other properties are less well defined, as chloride threshold value, and frost resistance. For the latter, good test methods exist and should be used. For chloride threshold there is no method available which is a big drawback in conjunction with evaluation of service life with regard to reinforcement corrosion.

13.2 Repair systems

Even if a certain repair material in itself has good properties, one cannot be sure that it functions well when combined with the old damaged structure. The whole repair system (repair material combined with the old structure) must fulfil the requirements. There are very few -if any- test methods for the repair system. Methods ought to be developed.

14 REQUIRED MATERIAL DATA FOR QUANTITATIVE EVALUATION OF SERVICE LIFE

14.1 Data required for analysing the general durability of the repaired structure

A quantitative service life evaluation requires material data for *repair materials* and the *old concrete*. A survey of required information for the following five frequent damage types is given in the tables below.

- Chloride induced reinforcement corrosion. Table 14.1.
- Carbonation initiated reinforcement corrosion. Table 14.2.
- Frost damage. Table 14.3.
- Leaching. Table 14.4.
- ASR. Table 14.5.
- Synergy between surface frost scaling and reinforcement corrosion. Data in tables 14.1, 14.2 and 14.3 are used

Test methods suitable for obtaining these data are also referred in the tables. Most methods are NORDTEST-methods (NT BUILD xxx). Many test methods are unsuitable for analysing durability of the repaired structure for the following reasons; (i) properties are often determined at fixed moisture levels that are not relevant for the practical application of the material, (ii) the interaction between the substrate concrete and the repair material is not considered at the test. Therefore, reference is also made to test methods described in reports.

14.2 Data required for analysing the mechanical interaction between repair material and old concrete

Also properties of the *interface* between repair materials and old concrete must be known. Such properties are:

- Bond directly after repair is made
- Loss of bond during service caused by temperature and moisture movement or frost action. Loss of bond caused by ageing (embrittlement) of the repair material.

These properties cannot be obtained by testing the repair material itself. Therefore, pre-tests have to be made on potential bond between the actual old concrete and the repair material, and that durability testing of the combination repair material–old concrete has to be made. Examples of suitable durability tests are given in Table 14.6.

Also the risk of *cracking* of repair materials has to be evaluated in cases where cracking might reduce service life, as for chloride induced corrosion. Cracking might occur:

- Short time after application of the repair material (primarily cement-based) caused by plastic shrinkage, chemical shrinkage, or thermal shrinkage of the repair material.
- During service due to differential stresses between old concrete and repair material caused by temperature or moisture changes.

The crack risk (and also the risk of bond loss) depends on the *mechanical and physical interaction* between repair material and old concrete. Such interaction can be analysed theoretically based on thermal and mechanical data for the repair material and old concrete (E-modulus, creep, moisture shrinkage, thermal expansion). Effect of possible ageing of the repair material (embrittlement) on the risk of cracking must be evaluated. As an alternative to calculations accelerated tests of the crack risk can be made.

Table 14.1: Chloride induced corrosion. Required material data.

Cause	Type	Method	Repair material Required data [Test method] ¹⁾	Old concrete Required data [Test method] ¹⁾
Chloride concentration at the bar is above the threshold concentration	Spalling and corrosion	New concrete cover	Eff. Cl-diffusivity [1] Thresh. chloride Conc. [2] Frost resistance [3]	Moisture data -transport diffusion [11] -transport capillarity [10] -moisture binding [12]
		New polymer cover	Eff. Cl-diffusivity [4] Durability of cover -pH [5] -UV [6] -Frost [7] -Chemical attack [8] Moisture transport, -diffusion [9] -capillarity [10]	
	No spalling but corrosion	New concrete cover	Eff. Cl-diffusivity [1] Thresh. chloride Conc. [2] Frost resistance [3]	
		Additional Concrete cover	Eff. Cl-diffusivity [1] Frost resistance [3] Moisture data -transport, diffusion [11] -transport, capillarity [10] -moisture binding [12]	Eff. Cl-diffusivity [1] Moisture data -See above [10-12] Thresh. chloride conc. [2] Chloride profile [14]
		Polymer coating	Eff. Cl-diffusivity [13] Durability of cover -See above [5-8] Moisture transport, diff. [9]	Eff. Cl-diffusivity [1] Chloride profile [14] Moisture data -See above. [10-12]
	No spalling no corrosion	Additional Concrete cover	Eff. Cl-diffusivity [1] Frost resistance [3] Moisture data -transport diffusion [10] -transport capillarity [11] -moisture binding [12]	Eff. Cl-diffusivity [1] Thresh. Chloride conc. [2] Chloride profile [14] Moisture data -See above [10-12]
		Polymer coating	Eff. Cl-diffusivity [13] Durability of cover -See above [5-8] Moisture transport, diff. [9]	Eff. Cl-diffusivity [1] Thresh. chloride conc. [2] Chloride profile [14] Moisture data -See above [10-12]

1) See list after Table 14.6

Table 14.2: Carbonation induced corrosion. Required material data

Cause	Type	Method	Repair material Required data [Test method]	Old concrete Required data [Test method]
Carbonation of the cover activates corrosion	Spalling corrosion	New concrete cover	Eff. CO ₂ -diffusivity [15]	Moisture data -transport diffusion [11] -transport capillarity [10] -moisture binding [12]
		New polymer cover	Eff. CO ₂ -diffusivity [16] Durability of cover -High pH [5] -UV [6] -Frost [7] -Chemical [8] Moisture transport [9-10]	
	No spalling corrosion	New concrete cover	Eff. CO ₂ -diffusivity [15]	Eff. CO ₂ -diffusivity [18] Carbonation depth [19] Moisture data -transport diffusion [11] -transport capillarity [10] -moisture binding [12]
		Additional concrete cover	Eff. CO ₂ -diffusivity [15] Moisture data -transport diffusion [11] -transport capillarity [10] -moisture binding [12]	
		Polymer coating	Eff. CO ₂ -diffusivity [17] Durability of cover -High pH [5] -UV [6] -Frost [7] -Chemical [8] Moisture transport, diff. [9]	
	No spalling no corrosion	Additional concrete cover	Eff. CO ₂ -diffusivity [15] Moisture data -transport diffusion [11] -transport capillarity [10] -moisture binding [12]	Eff. CO ₂ -diffusivity [18] Carbonation depth [19] Moisture data -transport diffusion [11] -transport capillarity [10] -moisture binding [12]
		Polymer coating	Eff. CO ₂ -diffusivity [17] Durability of cover -See above [5-8] Moisture transport, diff. [9]	

Table 14.3: Frost attack. Required material data

Cause	Type	Method	Repair material Required data [Test method]	Old concrete Required data [Test method]
Salt frost attack	Eroded surface	New concrete cover	Salt frost resistance [3] Strength	Strength of scaled (rinsed) surface [14] Chloride profile Scaling depth
		Polymer cover	Salt frost resistance [7] Strength, Stiffness “Durability” -High pH [5] -UV [6] -Chemical [8] Moisture transport [9-10]	
Internal frost attack	Loss of cohesion Internal cracking	Crack injection	Durability of injection inside concrete (high pH+high moisture) [20] “Penetrability” [21]	Internal moisture level [23] Residual strength -compressive -tensile -bond to reinforcement [24] Residual stiffness Moisture transport at high moisture level [10b] -capillarity [10a]
		Sealing the structure by applying polymer coating on of exposed surfaces	“Durability” -High pH [5] -UV [6] -Chemical [8] Moisture permeability -diffusion [9] -over-pressure [22]	
		Strengthening	Strengthening is individually designed Strength data for strengthening materials required	

Table 14.4: Leaching. Required material data

Cause	Type	Method	Repair material Required data [Test method]	Old concrete Required data [Test method]
Penetrating water dissolves lime	Loss of cohesion (strength)	Internal sealing by injection	Durability of injection inside concrete (high pH+high moisture)[20] “Penetrability” [21]	Residual strength -compressive -tensile -bond to reinforcement[24] Residual stiffness Amount of leached lime[25] Calcium concentration of leaching water [25] Rate of water flow
		Sealing the structure by casting new concrete on “upstream” face	w/c-ratio water permeability [22] Frost resistance [3]	
		Sealing” the structure by applying dense polymer coating on “upstream” face	“Durability” -frost [7] -UV [5] -High pH [6] -chemical [8] Water permeability [22]	

Table 14.5: ASR. Required material data

Cause	Type	Method	Repair material Required data [Test method]	Old concrete Required data [Test method]
Silicious aggregate reacts with alkaline pore water	Loss of cohesion Internal cracking	Crack injection	Durability of injection inside concrete (high pH+high moisture) [20] “Penetrability” [21]	Internal moisture level [23] Residual strength -compressive -tensile -bond to reinforcement [24] Degree of expansion [27] Potential further expansion [27] Residual stiffness Moisture transport at high moisture level [10b] -capillarity [10a]
		Sealing the structure to moisture ingress by applying dense polymer coating on exposed surfaces	“Durability” -High pH [5] -UV [6] -Chemical [8] Moisture permeability [9] Crack-bridging capacity [26]	
		Strengthening	Strengthening is individually designed Strength data for strengthening materials required	

Table 14.6: Interaction between old concrete and repair material. Required data

Type of damage	Type of evaluation [Test method or calculation method]	Data required [Test method]
Bond between repair material and old concrete	Pre-testing of potential bond [28]	<i>Test result</i> Bond strength
	Pre-testing of frost resistance of combination repair material-old concrete[29]	<i>Test result</i> - Risk of loss in bond - Risk of frost damage in old concrete
	Theoretical analysis of risk of bond failure (FEM-analysis)	<i>Test result:</i> Lab data for: * E-modulus, ductility and creep/relaxation of: - repair material [32] (virgin and aged) - old concrete [34] * Movement of repair: - due to moisture [35] - due to temperature [36] <i>Result of calculation:</i> -Risk of loss in bond
	Accelerated pre-testing of the risk of bond loss [30]	<i>Test result:</i> - Risk of loss in bond
Cracking of repair material due to: -moisture movement -temperature movement -stresses caused during production (e.g. temperature cracks in cement-based repair materials)	Theoretical analysis of risk of cracking [31]	<i>Lab data for hardened repair material and old concrete:</i> * E-modulus, ductility and creep/relaxation of: - repair material (virgin and aged) [32] - old concrete [34] * Movement - due to moisture [35] - due to temperature [36] <i>Lab data for hardening repair material:</i> * Heat development. [37] * Growth in strength and rheological properties of importance for thermal cracking [38] * Plastic and chemical shrinkage [6] <i>Result of calculations:</i> - Risk of cracking during service - Risk of cracking during production
	Accelerated pre-testing of the risk of cracking of "hardened" repair [32]	<i>Test result:</i> -crack risk
	Pre-testing of the risk of cracking during production [33]	<i>Test result:</i> - crack risk

Test methods (calculation methods)

- [1] NT BUILD 443 (Non-steady state diffusion in saturated concrete stored in 3% NaCl-solution).
NT BUILD 492 (Non-steady state migration in an electrical field).
Both methods give transport data for un-aged concrete. Ageing often causes a considerable reduction in the transport coefficient. Field diffusion data for aged concrete can be found in Table 15.2.
- [2] No test method exists. Field data for aged concrete can be found in Table 15.3.
- [3] SS 13 72 44 ("the slab test").
- [4] Possible NT BUILD 355 might be used. It gives steady-state migration of chloride in an electrical field. The method is intended for cement-based repair materials. Since the method is steady state no effect of chloride binding is considered.
- [5] A method based on the principles in NT BUILD 161 might be used. In this, the polymer is placed between moist concrete blocks. The alkali effect is monitored by tensile testing and DSC.
- [6] Method unclear.
- [7] Possibly SS 13 72 44 can be used. It is intended for cement-based concrete, but might also function for polymer concrete.
NOTE: For a concrete covered by polymer it is often the frost resistance of the combination of material that is of importance. For test method, see [29].
- [8] The method depends on the actual environment. For resistance to acid attack NT BUILD 363 might be used (exposure to H₂SO₄).

ANNEX 2 Evaluation with regard to service life. Quantitative evaluation

- [9] Method described in Hedenblad, literature reference [16] can be used. It gives the moisture diffusivity over the entire RH-range 0-98% RH). Alternative methods, like NT BUILD 279 or NT BUILD 369, only give one value of the moisture diffusivity valid for one rather low RH. It cannot be used for calculations of moisture conditions in the repaired concrete.
- [10] (a) NT BUILD 368. The method is intended for cement-based materials, but might also be used for polymer-based material. The method gives the liquid water absorption of pre-dried material. This is the maximum possible rate of water absorption. (b) A method described in Janz, literature reference [3], gives the liquid water absorption in specimens pre-conditioned to different initial moisture levels. See also literature reference [13].
- [11] Method described in Hedenblad, literature reference [12]. See also Nilsson, literature reference [11]. These methods give the moisture transport coefficient in the hygroscopic range (0-98% RH). For transport in the range 95-100% RH a method described in Janz, literature references [3] and [20] can be used.
- [12] *Hygroscopic range:* Method described in Ahlgren, literature reference [10]. Other methods to be used in the hygroscopic range are found in literature references [21] and [22].
Over-hygroscopic range: NT BUILD 481. The theoretical background is described in literature reference [23].
- [13] NT BUILD 489 (Comparison of non-steady state chloride diffusion of coated and uncoated specimens placed in 3% NaCl-solution).
- [14] A method of determining the chloride profile (total chloride) is described in NT BUILD 443 (sampling) combined with NT BUILD 208 (chloride analysis).
- [15] NT BUILD 357 (accelerated method, 3% CO₂ and 55-65% RH). Alternatively, non-accelerated or accelerated methods described in Utgenannt, literature reference [17], are used.
- [16] Method unclear.
- [17] NT BUILD 357.
- [18] Can be calculated from measurement of the carbonation depth and information on outer concentration of CO₂ and amount of lime able to carbonate, See equation (3.4).
- [19] The phenolphthalein method described in NT BUILD 357 might be used.
- [20] Methods for determining the alkali resistance of polymer-based injection material are unclear. Information must be furnished by the manufacturer.
- [21] Test method unclear. Choice of material can be based on test injections in the real structure.
- [22] Method for determining water permeability of a coating exposed to water over-pressure is unclear. The method might be an ordinary permeability test of concrete in which the upstream surface is coated. The method is described in Ekström, literature reference [7]. The measurement is made when steady state flow is reached.
- [23] *Moisture ratio in weight-%:* Drying and weighing representative samples at +105°C.
Degree of saturation: Method described in Fagerlund, literature reference [18].
- [24] Bond strength can be estimated from the split tensile strength. Some experimental relations can be found in literature reference [6c].
- [25] Method described in Ekström, literature reference [7] can be used.
- [26] Method unclear.
- [27] The techniques are described in literature reference [6b].
- [28] NT BUILD 365.
- [29] Test methods are described in Fagerlund & Svensson, literature reference [4]. See also Figure 11.1.
- [30] A test method for the risk of bond loss due to temperature cycles is described in Fagerlund & Svensson, Literature reference [4]. See also Figure 11.2.
Method for the risk of bond loss due to moisture cycles is unclear.
- [31] The risk of temperature induced cracking caused by temperature rise during production of concrete can be analysed by methods described in literature reference [19].
- [32] Method unclear.
- [33] The risk of plastic shrinkage of cement-based repair material might be tested by NT BUILD 366.
- [34] NT BUILD 205 for E-modulus. Methods for relaxation and creep are unclear.
- [35] NT BUILD 366.
- [36] NT BUILD 367.
- [37] Conduction calorimetry performed at two or more constant temperatures. suitable equipment: Calorimeter TAM Air produced by Thermometric AB, Sweden.
- [38] Technological Institute, Denmark. Method TI-B 102.

15 MATERIAL DATA FOR NORMAL CONCRETE

15.1 Introduction

Material data of interest for service life assessment can always be determined for each individual repair material. For polymer-based repair materials, and for concrete containing polymer additions this is necessary since properties such as chloride diffusivity, carbonation rate (effective CO₂-diffusivity), moisture absorption, moisture fixation, moisture transport, threshold value for onset of corrosion and other properties are very much affected by the actual composition of the material.

For normal concrete fairly well-defined data exist, however. Most properties are depending on the water/cement ratio. Some are depending on the chemical composition of the cement (binder). Typical data are presented below. They can be used for approximate evaluation of repair made with ordinary concrete and for evaluating the interaction between the repair material and the substrate concrete.

15.2 Moisture fixation

Absorption and desorption isotherms for mature OPC-concrete are shown in Figure 15.1; [10], [11].

The equilibrium moisture content always is between the two isotherms. The exact level depends on the moisture history. Moisture in a concrete that dries from total saturation is determined by the desorption isotherm. Moisture in a concrete that first dries and the takes up water is determined by a “scanning isotherm between the two limiting isotherms.

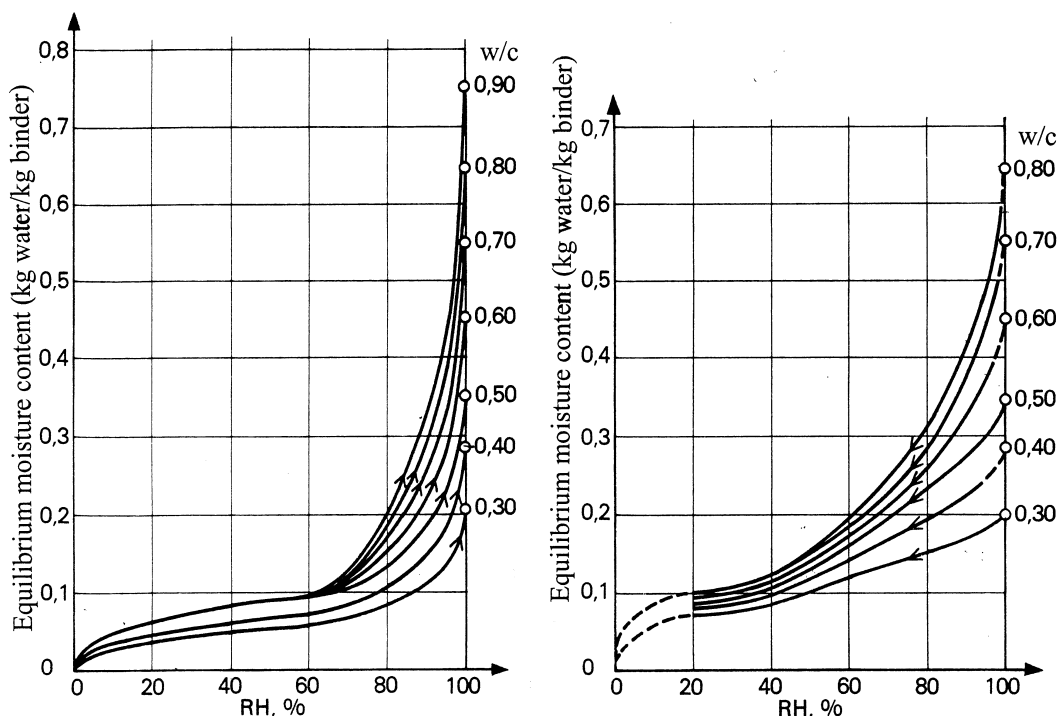

Figure 15.1

Sorption isotherms for mature OPC-concrete. Left: Absorption isotherms; [10].

Right: Desorption isotherms; [11].

5.3 Moisture transport within the hygroscopic range

Moisture transport below the capillary range (less than about 98% RH) is defined by

$$q = -\delta_v \cdot dv/dx \quad (15.1)$$

q is the moisture flow ($\text{kg}/\text{m}^2 \cdot \text{s}$)

δ_v is the moisture transport coefficient (m^2/s)

dv/dx is the gradient in water vapour concentration (kg/m^3 per m)

The transport coefficient is a function of the moisture content expressed in RH. Data for typical OPC-concrete are shown in Figure 15.2; [12].

Data are also shown in Table 15.1 for some RH-levels. The transport coefficient is fairly constant and independent of the w/c-ratio as long as RH is below 90%. At RH above 90% the transport coefficient grows rapidly with increased RH, especially for high w/c-ratio.

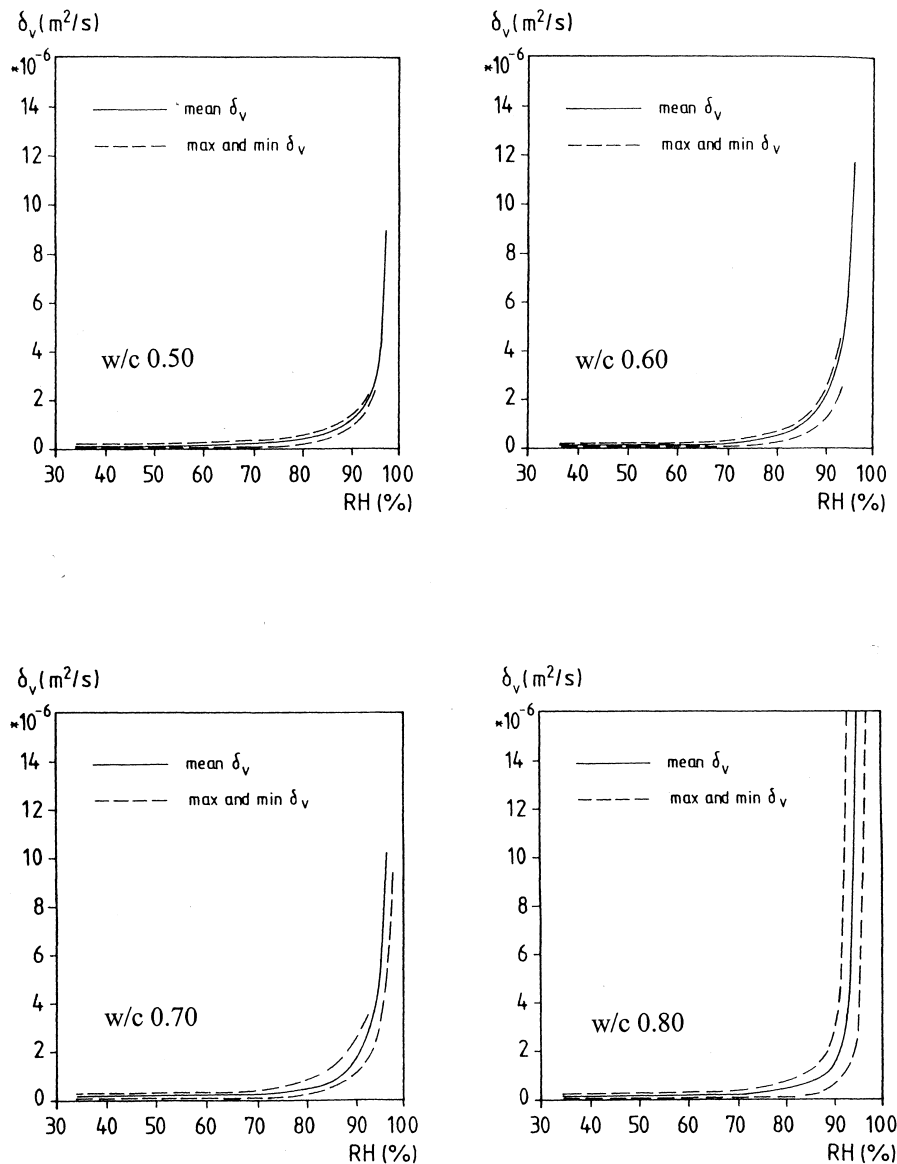

Figure 15.2

Moisture transport coefficient as function of the relative humidity; [12].

Table 15.1: Moisture transport coefficients for OPC-concrete; [12].

RH (%)	δ_c (m ² /s)·10 ⁶				
	w/c 0.4	w/c 0.5	w/c 0.6	w/c 0.7	w/c 0.8
33-65	0.13	0.14	0.15	0.18	0.18
70	0.19	0.20	0.19	0.19	0.30
80	0.28	0.33	0.38	0.40	0.37
84	0.35	0.45	0.64	0.58	0.48
86	0.39	0.59	0.83	0.77	0.60
88	0.46	0.82	1.18	0.99	0.76
90	0.53	1.02	1.74	1.44	1.34
92	0.57	1.48	2.6	2.3	2.4
94		2.2	4.3	3.4	6.8
95	0.70	2.8	5.4	4.4	12.7
96		4.3	7.8	6.4	19
97		9.0	11.7	10.0	28
98					53

15.4 Capillary water absorption

Capillary water uptake is determined by the following set of equations; [13].

$$t=m \cdot x^2 \quad (15.2)$$

$$Q=k \cdot t^{1/2} \quad (15.3)$$

$$q=k \cdot t^{1/2} / 2 \quad (15.4)$$

t is the suction time (s)

m is the resistance to penetration of the water front (m)

Q is the total absorbed amount of water (kg/m²)

k is the coefficient of capillarity (kg/(m²·s^{1/2}))

q is the rate of water absorption (kg/m²·s)

The relation between k and m is:

$$k=(1000 \cdot P_a) / m^{1/2} \quad (15.5)$$

P_a is the porosity taking part in the capillary water uptake process (m³/m³).

P_a is the total porosity of the concrete (P_{tot}) reduced with such pores that do not take part in the water absorption process; i.e. air-pores and other coarse pores that are difficult to fill with water (P_i), and pores already water-filled before suction starts (P_w).

$$P_a=P_{tot} - P_i - P_w \quad (15.6)$$

The value of m is fairly independent on the initial amount of water when suction starts. This means that the coefficient k is highly dependent on the initial water content. When the concrete is initially saturated ($P_a=0$), k is of course zero, which also follows from equation (15.5).

Experimentally determined values of m for OPC are shown in Figure 15.3; [13]. The value is almost directly proportional to the capillary porosity (P_c).

$$m \approx 11 \cdot (1 - 2 \cdot P_c) \cdot 10^7 \quad (\text{s/m}^2) \quad (15.7)$$

$$P_c = (w/c - 0.39 \cdot \alpha) / (w/c + 0.32) \quad (15.8)$$

α is the degree of hydration

The coefficient k depends on the initial moisture content. A maximum value occurring in practice is obtained when the concrete has an initial water content corresponding to about 50%RH. Then, for mature concrete with cement content $C \text{ kg/m}^3$ the value of k can be calculated by:

$$k_{50\%RH} \approx C(w/c - 0.27) \cdot m^{-1/2} \quad (15.9)$$

For concrete with an initial water content corresponding to 90% RH, the value of k is:

$$k_{90\%RH} \approx C(0.48 \cdot w/c - 0.16) \cdot m^{-1/2} \quad (15.10)$$

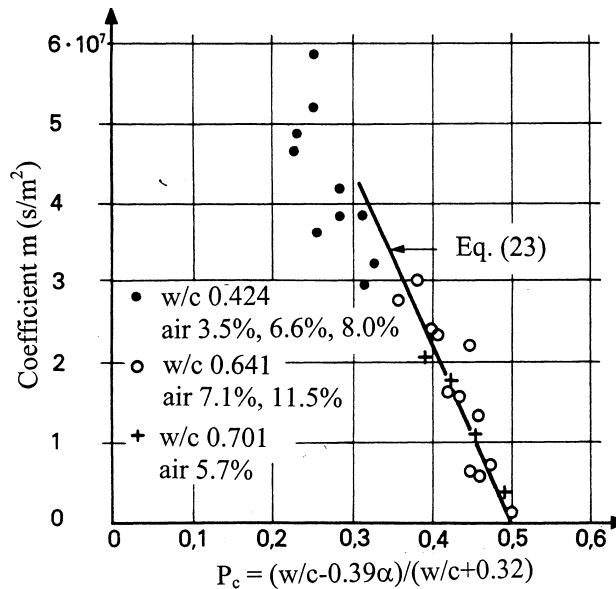

Figure 15.3

The coefficient of water penetration m versus the capillary porosity of the cement paste; [13].

Example:

Consider a mature repair concrete with $w/c=0.40$ ($\alpha=0.7$). Cement content 400 kg/m^3 . The concrete sucks water for 24 hours ($8.64 \cdot 10^4 \text{ s}$).

$$P_c = (0.40 - 0.39 \cdot 0.7) / (0.40 + 0.32) = 0.18 \text{ m}^3/\text{m}^3$$

$$m = 11 \cdot (1 - 2 \cdot 0.18) \cdot 10^7 = 7.0 \cdot 10^7 \text{ s/m}^2$$

$$k_{50\%RH} = 400(0.40 - 0.27)(7.0 \cdot 10^7)^{-1/2} = 0.006 \text{ kg}/(\text{m}^2 \cdot \text{s}^{1/2})$$

$$Q_{50\%RH} = 0.006 \cdot (8.64 \cdot 10^4)^{1/2} = \mathbf{1.7 \text{ kg/m}^2}$$

The depth of the water front after 24 hours is:

$$x_{24 \text{ hours}} = (8.64 \cdot 10^4 / 7.0 \cdot 10^7)^{1/2} = 0.035 \text{ m} \quad (\mathbf{3.5 \text{ cm}})$$

The w/c-ratio is increased to 0.7 and cement content 250 kg/m³. The amount of water taken up during the same time is increased to **7.4 kg/m²**. The depth of the water front is increased to **6.9 cm**.

15.5 Permeability to water under pressure

The flow of water forced through concrete by overpressure can be described by Darcy's law, which expressed in SI-units is:

$$q = B \cdot (\Delta P / \Delta x) \quad (15.11)$$

where

q is the water flux (kg/(m²·s))

ΔP is the overpressure difference over the distance Δx (Pa/m)

B is the coefficient of permeability (s)

The coefficient B depends on the w/c-ratio, but also on the size of aggregate, and the porosity of this. It is also dependent on defects in the concrete like cracks.

For OPC-concrete the data in Figure 15.4 might be used. The data are emanating from different reports. The compilation of data comes from [6d].

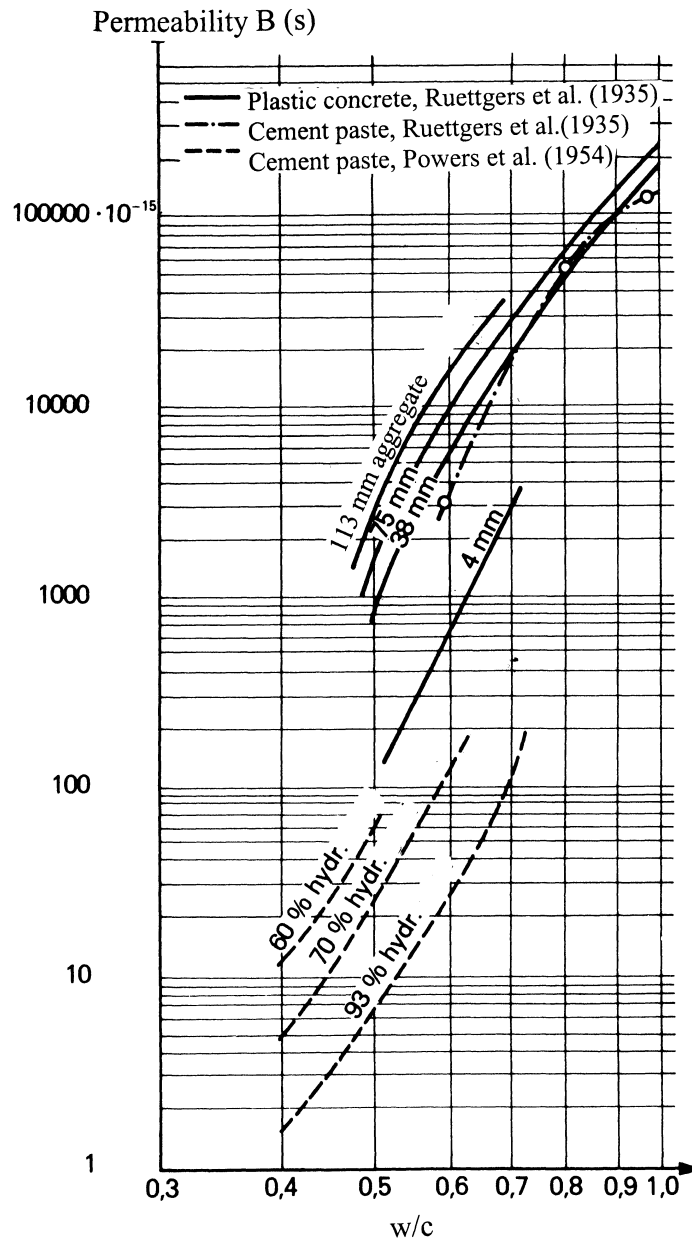

Figure 15.4
 Permeability of concrete, cement mortar and cement paste. Compilation of data from literature performed in [6d].

15.6 Carbonation rate

The carbonation rate is determined by the square-root relation (2.1). The rate-determining coefficient D in the equation is determined by the diffusivity of CO_2 in concrete (δ m^2/s), by the amount of matter in concrete able to carbonate (M mole/m^3), and by the concentration of CO_2 in outer air diffusing into the concrete (c_o mole/m^3):

$$D=(2\cdot\delta\cdot c_o/M)^{1/2} \quad (15.12)$$

This means that carbonation is slower the higher the amount of matter able to carbonate and the lower the diffusivity. The latter is highly dependent on the moisture content in the concrete; the higher the moisture content, the lower the diffusivity.

For repair material based on OPC-concrete the carbonation rate can be obtained graphically from Figure 3.3; [5].

15.7 Diffusion of chloride ions

Transport of chloride ions can be described by Fick's law:

$$q = -\delta_{\text{eff}} \cdot dc/dx \quad (15.13)$$

where

q is the flow of chloride ($\text{mole}/\text{m}^2 \cdot \text{s}$)

δ_{eff} is the effective transport coefficient including the effect of chloride binding (m^2/s)

dc/dx is the gradient in chloride concentration (mole/m^3 per m)

Instead of using the units mole/m^3 and mole/m^2 one can use the combination kg/m^3 and kg/m^2 .

The chloride diffusivity of high quality concrete has been determined by field testing of structures exposed to different types of environment. Data presented in Table 15.2 have been found; [14].

The diffusivity depends not only on the concrete quality, but also on the moisture condition in the concrete cover. This effect is included in the values in the table since these are based on real chloride distribution curves in structures that are more or less moist.

15.8 The threshold chloride concentration

The threshold concentration for start of reinforcement corrosion is not very well known. Moreover, there is no test method available for its determination. Therefore, one has to rely upon rather uncertain field data. A compilation of data from literature is made in Table 15.3; [14]. The chloride concentration is expressed as total chloride content (free+bound) in relation to the amount of binder (OPC+MS+FA).

Theoretically the free chloride is a better measure since it is only free chloride ions that can initiate corrosion. The free chloride concentration can be calculated from the total chloride by using the binding isotherm for chloride. Unfortunately the binding isotherms are not very well known. Some data are given in [5]. Others are presented in [15].

Table 15.2: Effective chloride diffusion coefficients for crack-free concrete. The data have been collected from concrete field exposed during differently long periods in different exposure types; [14]. (The exposure time in years that is valid for the measured diffusivity is shown in italics in the column next to the diffusivity)

Binder type	$\delta_{\text{eff}} \text{ m}^2/\text{s}\cdot 10^{-12}$							
	sea water immersed		sea water splash zone		de-icing salt splash zone		de-icing or marine atmosphere zone	
	w/b=0.50							
OPC	4-7	2y	2-4	2y			2-3	2y
			0.1-2	<i>10-15 y</i>	2-4	<i>20-30y</i>	0.1-1	<i>15-20y</i>
			0.1-1	<i>30-40y</i>	0.5-2	<i>30-40y</i>		
OPC+ 5-1% MS	2-4	2y	1-3	2y			1-2	2y
	1-2	<i>5-8y</i>	0.5-1	<i>5-8y</i>				
OPC+ 10-20% FA	2-6	2y	3-5	2y			1-2	2y
	1-2	<i>5-8y</i>	1-3	<i>5-8y</i>			0.1-0.7	<i>15-20y</i>
	w/b=0.40							
OPC	2-4	2y	1-3	2y			1-2	2y
			0.5-2	<i>5y</i>				
			0.5-1	<i>10-15y</i>	0.5-2	<i>20-30y</i>		
			0.2-0.5	<i>30-40y</i>	0.1-0.8	<i>30-4y</i>		
OPC+ 5-10% MS	0.5-2	2y	0.5-1	2y			0.3-0.8	2y
	0.5-1	<i>5-8y</i>	0.2-0.5	<i>5-8y</i>				
OPC+ 10-20% FA	0.5-3	2y	0.6-2	2y			0.6-2	2y
	0.5-2	<i>5-8y</i>	0.5-3	<i>5-8y</i>			0.1-0.3	<i>4y</i>
	w/b=0.30							
OPC	1-3	2y	1-2	2y			0.7-1	2y
OPC+5-10% MS	0.4-1	2y	0.2-0.6	2y			0.2-0.5	2y
OPC+10-20% FA	1-2	2y	0.5-2	2y			0.5-2	2y

MS= silica fume (Microsilica). FA= fly ash.

Table 15.3: Threshold concentration of total chloride for start of corrosion; [14]. Figures in brackets give the assumed spread in the value. Figures in italics are uncertain.

Environment	(w/c) _{max}	Chloride threshold of acid soluble chloride (weight-% of binder)			
		OPC	OPC+ 8% MS	OPC+ 15% FA	OPC+ 15slag
Low chloride load Repeated moistening and drying	0.45	0.7 (0.6-2.2)	0.4 (0.3-1.5)	0.5	0.5
Low chloride load Constant high moisture	0.45	1.5 (1.5-2.2)	0.8 (0.8-1.9)	1.0 (0.9-1.4)	1.0 (0.8-2.0)
Marine environment	0.40	0.8 (0.6-2.2)	0.5 (0.5-1.0)	0.6 (0.4-0.8)	0.6 (0.5-1.2)
De-icing salt	0.40	0.6 (0.4-1.0)	0.3	0.4	0.4

REFERENCES

- [1] Fagerlund, G., Hedenblad, G.: *Calculation of the moisture-time fields in concrete*. Div. Building Materials, Lund Institute of Technology. Report TVBM-3052, Lund 1993.
- [2] Arfvidsson, J.: *Computer models for moisture flow in porous media*. Div. Building Physics, Lund Institute of Technology, Report TVBH-7108, Lund 1994.
- [3] Janz, M.: *Moisture transport and fixation in porous materials at high moisture levels*. Lund Institute of Technology, Div. of Building Materials. Report TVBM-1018. Lund, Sweden 2000.
- [4] Fagerlund, G., Svensson, O.: *Durability of repair systems for concrete balconies*. Swedish Cement and Concrete Research Institute. Research Fo 2:80, Stockholm, 1980.
- [5] Tuutti, K.: *Corrosion of Steel in Concrete*. Swedish Cement and Concrete Research Institute. Research Fo 4:82, Stockholm, 1982.
- [6] CONTECVET. *A validated Users Manual for assessing the residual service life of concrete structures*. EC Innovation project IN30902I. Terminated 2001.
(a) Andrade, C., Rodriguez, J. (Editors and main authors): *Manual for assessing corrosion-affected concrete structures*. Available from IETcc Madrid.
(b) Somerville, G. (Editor and main author): *Manual for assessing concrete structures affected by ASR*. Available from British Cement Association, Crowthorne, UK.
(c) Fagerlund, G. (Editor and main author): *Manual for assessing concrete structures affected by frost*. Available from Div. Building Materials, Lund Institute of Technology, Lund, Sweden.
(d) Fagerlund, G. (Author): *Leaching of concrete. The leaching process. Extrapolation of deterioration. Effect on structural stability*. Div. Building Materials, Lund Institute of Technology, Report TVBM-3091, Lund, 2000.
- [7] Ekström, T.: *Leaching of concrete. The leaching process and its effects*. Lund Institute of Technology, Div. of Building Materials. Report TVBM-1020. Lund, Sweden 2003.
- [8] Swedish Standard SS 13 72 44. "Scaling at freezing".
- [9] Fagerlund, G.: *Synergetic effects of combined destructive action on concrete*. Contribution to Celebrating Concrete, People and Practice. Conference, Dundee 3-4 September 2003.
- [10] Ahlgren, L.: *Moisture fixation in porous building materials*. Dept. of Building Technology, Lund Institute of Technology. Report 36, Lund 1972.
- [11] Nilsson, L-O.: *Hygroscopic moisture in concrete: Drying measurements and related material properties*. Div. Building Materials, Lund Institute of technology, Report TVBM-1003, Lund, 1980. (In Swedish).
- [12] Hedenblad, G.: *Moisture permeability of mature concrete, cement mortar and cement paste*. Div. Building Materials, Lund Institute of technology, Report TVBM -10214, Lund, 1993.
- [13] Fagerlund, G.: *On the capillarity of concrete*. Nordic Concrete research. Nordic Concrete Federation. Publication No 1, Oslo 1982.
- [14] *Durable Concrete Structures*. Swedish Concrete Association. Concrete Report No 1, Issue 2. Stockholm, 1998.
- [15] Tang, Luping.: *Chloride Transport in Concrete*. Dept of Building Materials, Chalmers University of Technology. Publication P-96:6. Gothenburg, 1996.
- [16] Hedenblad, G.: *Material data for moisture calculations*. Swedish Building Research Council. Report T19:1996, Stockholm, 1996 (In Swedish)

ANNEX 2 Evaluation with regard to service life. Quantitative evaluation

- [17] Utgennant, P.: *The influence of ageing on the salt-frost resistance of concrete*. Div. Building Materials, Lund Institute of Technology, Report TVBM-1021, 2004.
- [18] Fagerlund, G.: *The critical degree of saturation method of assessing the freeze/thaw resistance of concrete*. Materials and Structures, Vol 10, No 58, 1977.
- [19] Anon.: *BRO 2002 (Bridge Norm)*, ANNEX 4-11. Swedish National Road Authorities, 2002.
- [20] Janz, M.: *Methods of measuring the moisture diffusivity at high moisture levels*. Div. building Materials, Lund institute of technology, Report TVBM-3076, Lund 1997.
- [21] Wadsö, I., Wadsö, L.: *A new method for determination of vapour sorption isotherms using a twin double calorimeter*. Thermochemica Acta, Vol 271, pp 179-187, 1996.
The same authors: *A second generation twin double microcalorimeter: Measurements of sorption isotherms, heats of sorption and sorption kinetics*. J. of Thermal Analysis, Vol 49, pp 1045-1052, 1997.
- [22] Johannesson, B., Janz, M.: *Test of four different experimental methods to determine sorption isotherms*. J. of Materials in Civil Engineering, Vol 14, No6, pp 471-477, 2002
- [23] Janz, M.: *Technique for measuring moisture storage capacity at high moisture levels*. J. of Materials in Civil Engineering, Vol 13, No5, pp 364-370

APPENDIX 1

ASSESSMENT OF MOISTURE STATE IN REPAIRED CONCRETE

CONTENTS	Page
1 INTRODUCTION	51
1.1 Chemical attack	51
1.2 Electrochemical attack – corrosion	51
1.3 Physical attack – frost	52
1.4 Adhesion	53
1.5 Desired moisture state after repair	55
2 QUALITATIVE ASSESSMENT	56
3 QUANTITATIVE ASSESSMENT	57
3.1 Introduction	57
3.2 Description of moisture transport in porous media	57
3.2.1 Diffusion: Isothermal conditions	57
3.2.2 Viscous saturated flow	58
3.2.3 Capillary transport	58
3.2.4 Total moisture transport: Isothermal conditions	60
3.2.5 Total moisture transport: Non-isothermal conditions	61
3.2.6 Two-phase flow and interaction	62
3.2.7 Moisture transport above capillary saturation	63
3.2.8 Methods of determining moisture diffusivity	65
3.3 moisture fixation in porous materials	65
3.3.1 Methods of determining moisture fixation	66
3.4 Calculation of moisture redistribution	67
3.4.1 Transient calculations	67
3.4.2 Steady-state moisture flow in one dimension	67
3.5 Obstacles	68
4 REFERENCES	70

1 INTRODUCTION

Concrete and porous repair materials will always contain a certain amount of moisture. The moisture content is strongly associated with numerous durability problems in structures. Each durability problem requires different moisture conditions. Some durability problems with related requirements are shortly described below.

The repair material used on a structure will always affect the moisture content and consequently also affect the durability and remaining service life. Accurate prediction of the service life of concrete structures – repaired or not – requires therefore good models of vapor and liquid transport, including knowledge of related properties such as moisture diffusivity and moisture storage capacity.

1.1 Chemical attack

Water can, especially if it is very pure, itself be aggressive and damage the concrete by dissolving lime (leaching). The amount of dissolved lime depends among other things on the moisture transport through the concrete.

Water can also constitute as a transport media in which aggressive compound, such as acids and sulfate, can be transported by diffusion or convection. Thus, if these aggressive compounds should affect the concrete, the moisture content must be high enough so that a continuous water phase is formed in the pore system.

Other durability problems are restrained by high moisture content. One example of such durability problem is when atmospheric carbon dioxide diffuses into the concrete and thereby reacts with calcium hydroxide forming calcium carbonate. This in turn will decrease the pH value to a level below 9 and thus make corrosion on the reinforcement possible. Diffusion of carbon dioxide is restrained by liquid water in the pores. Therefore the carbonation is very low in water-saturated concrete, while it can be considerable in dry concrete.

Additional chemical attacks involve pessimal moisture content at which the degradation rate is at a maximum. Alkali-silica reaction (ASR) is such an example. ASR is a reaction between certain forms of silica occasionally present in the aggregate and the alkali in the in the pore solution. ASR damages concrete structures due to the expansion of the reaction product consisting of a viscous gel. The expansion can induce internal stresses within the concrete, which might cause cracking. Pessimial moisture content has been recognized at which the damages are largest. There are several causes of this pessimum. One is that the viscosity of the gel is very affected by the moisture content. A small increase in moisture content will cause a decrease in viscosity and thereby a possibility of the gel to penetrate the surrounding pore system and thus expand without causing any pressure. On the other hand there must be sufficient solvent (liquid water) for the ions in the pore system. Water is also acting as a transport medium through which the ions are transported to the silica containing aggregate.

This state of opposition causes a pessimum. For instance: according to [1] the risk of pop-outs (a piece of the concrete surface is pushed out by the swelling of the gel from an aggregate close to the surface causing a crater) is highest at a relative humidity (RH) of approximately 90%.

1.2 Electrochemical attack – corrosion

Corrosion of steel embedded in concrete is a very complex problem. Steel in concrete normally is passive due to the alkaline environment. The passive state is maintained until the

concrete surrounding the steel becomes carbonated so that the pH decreases, or if there are sufficient amount of chloride ions at the steel surface. As mentioned above the diffusion rate of carbon dioxide and thus the carbonation rate are highest when the moisture content is low. Transport of chloride ions into the concrete require on the other hand a continuous water phase in the pore system.

Two additional conditions must be fulfilled for the corrosion of steel: (i) there must be an electrolyte, constituted by the pore solution, present and (ii) the cathodic reaction requires oxygen. Hence, if the concrete is very dry the amount of electrolyte will be low and consequently also the corrosion rate. If the concrete on the other hand has very high moisture content the transport of oxygen to the cathode will be slow and thus also the corrosion rate. This will cause pessimal moisture content at which the probability of corrosion and the corrosion rate will be highest. Figure 1 and 2 clearly shows this pessimum.

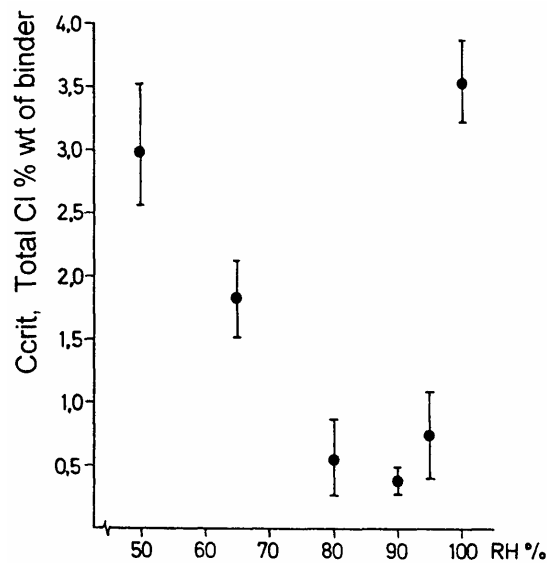

Figure 1 Total chloride thresholds for mild steel bars in mortar with a w/c = 0.50, conditioned at different RH [2].

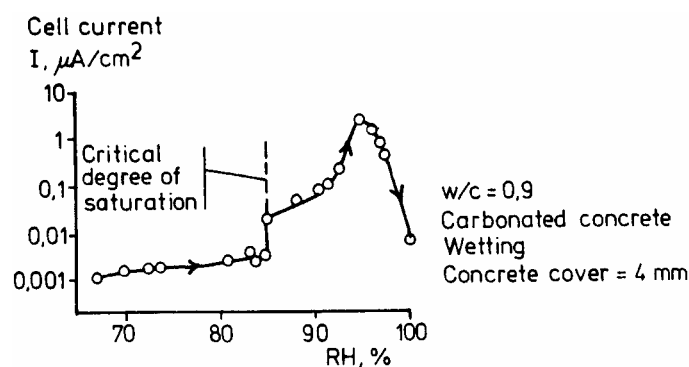

Figure 2. Measured cell current as a function of the relative humidity in carbonated concrete [3].

1.3 Physical attack – frost

The frost damage can be divided into internal frost damage, caused by freezing of water inside the concrete, and salt frost scaling, caused by freezing of the concrete surface while it stays in contact with an saline solution. It is obvious that frost damages in many respects are a

moisture problem. The damages are caused by the 9% expansion that occur when the liquid water freezes to ice. In order to cope with the expansion the concrete must contain a certain amount of air filled pores, hence there exist a moisture content, the critical degree of saturation (S_{cr}), above which the concrete always will be seriously damaged if it simultaneously exposed to frost. If the actual degree of saturation (S_{act}) is below S_{cr} no damage will occur. By measuring the loss of dynamic E -modulus after freezing test specimens it is possible to evaluate S_{crit} [4]. From the 9% expansion that occurs during freezing of water it is possible to calculate the maximum critical degree of saturation to 0.917. The actual S_{cr} is normally considerably lower due to other simultaneous mechanisms damaging the concrete, e.g. the hydraulic pressure built up when liquid water are transported to the growing ice. Figure 2 shows an example of measured S_{crit} .

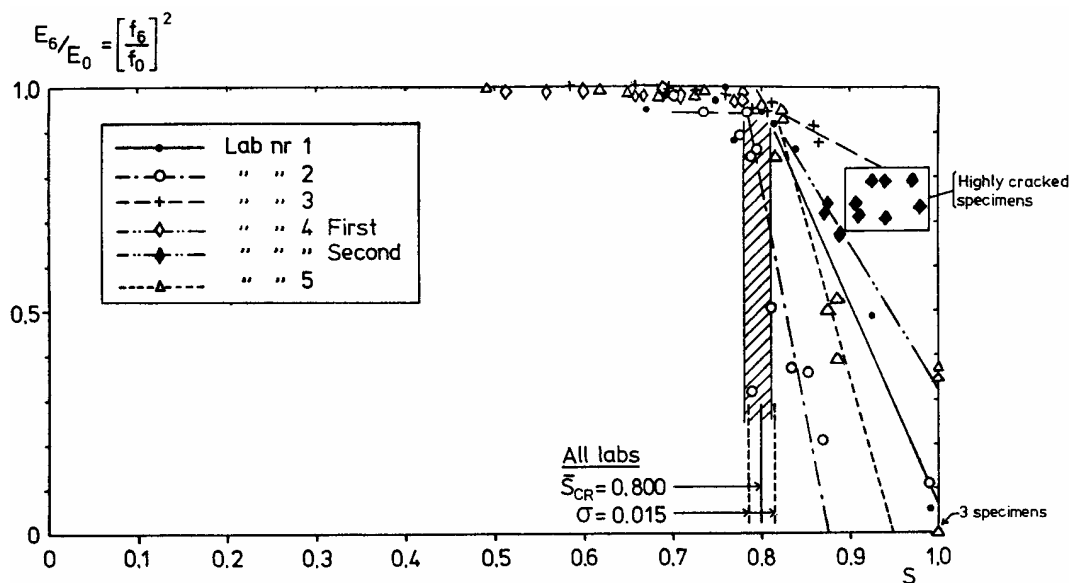

Figure 2 Residual dynamic E -modulus versus degree of saturation. S_{cr} appears very distinct. All specimens with moisture content above S_{crit} are seriously damaged with an evident loss of dynamic E -modulus [5].

1.4 Adhesion

Poorly initial adhesion and loss of adhesion has different causes dependent on the origin of the coating or repair material. For an example, the performance of a porous and diffusion open cement-based coating will of course be very different from a thin dense coating. However, low initial adhesion and loss of adhesion can among other things be a moisture related problem.

It is well known how to reach a good adhesion between concrete and a cement-based material. The result is mainly dependent on the execution, including the whole chain from removal of old concrete to curing. Normally the adhesion does not decrease in time. Differences in shrinkage can however cause delimitation and thus loss of bond.

The adhesion between concrete and polymeric coatings can on the other hand decrease with time, which in turn can lead to abrasion and blisters in the cover. Loss of bond has many causes, e.g. low durability against alkali or ultra violet light, differences in thermal expansion or moisture shrinkage between the coating and concrete and vapor pressure. Synergy can of course also occur between different mechanisms.

One explanation to the loss of bond that often arises is the difference in vapor pressure over the coating that occurs when the concrete has very high moisture content. But at normal temperatures the vapor pressure is too low to alone be the cause of e.g. blisters. Vapor

pressure can only give rise to blisters when the bond already has decreased considerable or at very high temperatures. Figure 3 shows the vapor pressure at saturation, that is the highest possible pressure acting on a coating. As appears from the figure, the vapor pressure is considerable lower than normal adhesion.

Thus, moisture is frequently involved when the bond is lost. Moisture within the concrete can induce loss of adhesion. The risk of freeze damage of the concrete is also obvious if moisture becomes entrapped in the concrete by the coating. The permeability of the coating must therefore be high enough so that vapor can leave the concrete.

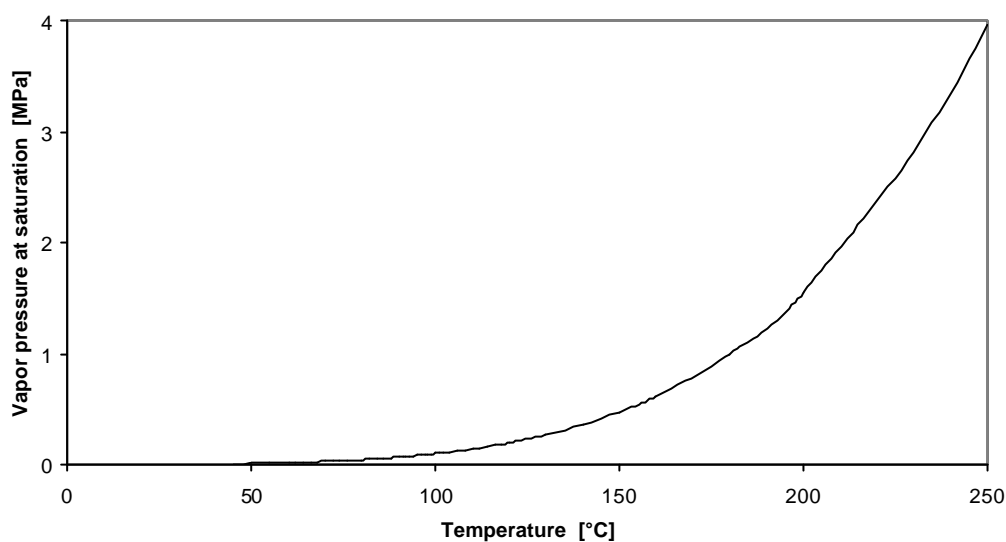

Figure 3 Relation between vapor pressure at saturation and temperature.

1.5 Desired moisture state after repair

A successful repair or rehabilitation should result in a moisture content and moisture transport that limit or, at best, stop further degradation. Which moisture content or transport that accomplishes this depends on the degradation process active. Table 1 shows examples of different degradation processes and the change in moisture state that a repair or rehabilitation should produce.

Table 1 Examples of degradation processes and requested change in moisture state.

Degradation process	Change of moisture state	Purpose
<i>Corrosion</i>		
Concrete contaminated with chloride. The concentration at the reinforcement is under the threshold value.	Decreasing moisture content	Slower or no further transport of chloride.
Concrete contaminated with chloride. The concentration at the reinforcement is over the threshold value. Ongoing corrosion.	Decreasing moisture content	Deficiency of electrolyte and thus slower corrosion rate or no further corrosion.
	Saturation at the cathode	Deficiency of oxygen and thus limiting the reaction rate at the cathode. Cathodic areas will be unable to drive an anodic reaction. Corrosion will consequently stop or be slower. ¹
Concrete carbonated to a depth less than the cover.	Increasing moisture content	Liquid water in the pore system will prevent further transport of CO ₂ .
Concrete carbonated to the reinforcement. Ongoing corrosion.	Decreasing moisture content	Deficiency of electrolyte and thus slower corrosion rate or no further corrosion.
	Saturation at the cathode	Deficiency of oxygen and thus limiting the reaction rate at the cathode. Cathodic areas will be unable to drive an anodic reaction. Corrosion will consequently stop or be slower. ¹
<i>Frost</i>	Decreasing moisture content	Reduction of freezable water to a level under the critical degree of saturation will stop further frost attack.
<i>ASR</i>	Decreasing moisture content	Slower or no further transport of alkali to areas with reactive silica (normally reactive aggregate).
	Increasing moisture content	Increasing viscosity of the reaction product (gel) make it possibility for the gel to penetrate the surrounding pore system. ²
<i>Leaching</i>	Decreasing moisture transport	Reduction of the amount of dissolved lime.

¹⁾ Limiting or stopping the corrosion by cathodic control will normally be difficult but is theoretically possible.

²⁾ Increasing the moisture content sufficiently is theoretically, but normally not practically, possible.

2 QUALITATIVE ASSESSMENT

A qualitative assessment can be based on:

- Experience from previous performed repair work.
- Common sense

The experiences of some repair techniques are extensive. For an example: replacing damaged concrete with new concrete is a very common repair technique from which a great deal of experience exist, both good and bad. Therefore it is normally possible to prescribe how a successful bonded concrete overlay should be performed.

The requirements based on previous experience could for an example be expressed as “the repair material is acceptable if the moisture permeability is lower or higher than a certain value”. However, these kinds of requirement require that the substrate and environment is similar to what the experience is based on. If a well-known and well functioning repair material or technique is used for a new application it is not obvious that it still will produce a durable repair. One clear example of this is when it from experience is stated that a coating will have a protective function with regard to frost damage if it is dense enough. Even if this fact might be justified from experience in some cases this repair will be a total failure if it is used on a structure where the moisture can reach the concrete from some other surface, i.e. absorbing water from the ground water. In this case it is a disadvantage with a dense coating. Experience of a repair technique must hence be associated to a certain environment and quality of the substrate.

Qualitative assessment based on common sense can in limited extent be used on new materials and new application. The “common sense” demands however a great deal of experience and knowledge of degradation processes and moisture mechanics. This kind of assessment will lead to an educated guess that only can be done by a person with high engineering skill. The assessment can result in statements such as: “the repair material *should* be acceptable if the moisture permeability is lower or higher than a certain value”.

The European standard EN 1504 part 1 to 10 gives some support in how different moisture characters should be, i.e. the permeability to water vapor and capillary absorption and permeability to water. For example: if a coating should be used as protection from ingress it is stated that the performance requirement with regard to the capillary absorption and permeability to water measured with the test method EN 1062-3 should be less than $0.1 \text{ kg}/(\text{m}^2 \cdot \text{h}^{1/2})$. However, the performance requirements found in the standard are not always as resolute as shown above. For the same example should also the permeability to water vapor be measured. The performance requirement given is however divided in three “Classes”. Class I: $s_D < 5 \text{ m}$ (permeable to water vapor), Class II: $5 \text{ m} \leq s_D \leq 50 \text{ m}$ and Class III: $s_D > 50 \text{ m}$ (not permeable to water vapor). The s_D value means that the diffusion of vapor through the coating is analogous with diffusion of vapor in an air layer with a thickness of s_D . The standard do not say which of the different classes should be used.

In order to make a more precise assessment of products, repair techniques and applications it is preferable to perform a quantitative assessment.

3 QUANTITATIVE ASSESSMENT

3.1 Introduction

It is of course desirable to be able to calculate the expected moisture content in a structure after a completed repair. In order to do that one must have a mathematical description of moisture transport with corresponding transport properties. Fick's law is often used to describe moisture transport in the hygroscopic range. Several well-documented methods of measuring the corresponding transport properties are available (see e.g. [6]). Generally the mathematical description (Fick's law), together with applicable transport properties, gives for some applications satisfactory results within the hygroscopic range. Transport properties have been measured on several different concrete qualities and other materials (e.g. [7]).

Diffusion theory based on Fick's law is also often used at high moisture levels, even though moisture transport principally occurs in the liquid phase. It is convenient not to have to change the mathematical description of the transport when the moisture level reaches a certain level.

In e.g. [8] it is shown that good agreement can be obtained on some materials with this approach. However, for concrete and most other materials the agreement of moisture calculations is lower at high moisture levels, partly because of the lack of reliable transport properties. It is considerably more difficult and requires major technical effort to measure moisture properties at high moisture levels.

Thus, at high moisture levels, where most durability problems occur, it is difficult to calculate the moisture content. Combining two materials, e.g. a repair material on an old concrete, it becomes even more difficult.

In order to calculate the moisture transport over an interface between two materials or through the boundary one must also know the moisture storage capacity for each material involved, i.e. the relation between the amount of physically bound water in a material and the relative humidity (or some other continuous potential). This relation must be determined experimentally and can e.g. be expressed by sorption isotherms (RH versus moisture content) in the hygroscopic range or by water retention curves (suction versus moisture content) at high moisture levels.

Below some basic theory of moisture transport (section 3.2), moisture fixation (section 3.3) and calculation methods (section 3.4) are presented. Methods of determining relevant material properties are also presented (section 3.2 and 3.3).

3.2 Description of moisture transport in porous materials

Moisture transport phenomena in porous media can be divided into *vapor diffusion*, *saturated viscous flow*, and *capillary (liquid) transport*.

3.2.1 Diffusion: Isothermal conditions

Diffusion at isothermal conditions is driven by a difference in vapor pressure, i.e. the water molecules are moving toward a lower vapor pressure. The most common way to describe the diffusion process is Fick's law:

$$g = -d_p \frac{\partial p_v}{\partial x} \quad (1)$$

where

- g is the density of moisture flow rate [$\text{kg}/(\text{m}^2 \cdot \text{s})$]
- d_p is the moisture permeability [$\text{kg}/(\text{m} \cdot \text{s} \cdot \text{Pa})$];
- p_v is the vapor pressure [Pa].

The moisture permeability is a function of the vapor pressure, i.e. $d_p = f(p_v)$.

3.2.2 Viscous saturated flow

Viscous saturated flow is driven by a difference in water pressure. The flow depends both on the pore geometry of the porous material and on properties of the fluid itself. Saturated flow g [$\text{kg}/(\text{m}^2 \cdot \text{s})$] is often described by Darcy's law, which for a one-dimensional case becomes:

$$g = -\frac{k_P}{h} \frac{dP}{dx} \quad (2)$$

where P is the water pressure [Pa], k_P is the permeability [kg/m^2] and h is dynamic viscosity [$\text{Pa} \cdot \text{s}$].

Fick's law and Darcy's law are widely used for calculating diffusion and saturated flow in porous material. However, there is no such generally accepted formula for calculating *capillary transport* through a porous material.

3.2.3 Capillary transport

The simplest model of calculating *capillary transport* is to approximate the wetted region as a fully saturated rectangular wet front, a sharp wet front or a moving boundary. For many applications, this model is accurate enough. The penetration depth of a sharp wet front can be calculated by:

$$x = B \sqrt{t} \quad (3)$$

where B [$\text{m}/\text{s}^{1/2}$] is the penetration coefficient, which has to be determined experimentally, and t is the time. The magnitude of B is dependent on the geometry of the liquid–vapor menisci, the surface tension, the contact angle, and the viscosity of the liquid. Since the geometry of the liquid–vapor menisci is in turn dependent on the degree of saturation, the penetration coefficient B will also be a function of the state of saturation in the material.

If it is assumed that the moisture penetration is a sharp wet front, the total amount of absorbed liquid W [kg/m^2] can be denoted by:

$$W = A \sqrt{t} \quad (4)$$

where the sorption coefficient A [$\text{kg}/(\text{m}^2 \cdot \text{s}^{1/2})$] is:

$$A = r P_a B \quad (5)$$

and where

- r is the liquid density [kg/m^3];
- P_a is the active porosity available for capillary transport [m^3/m^3].

The flow rate $g_{x=0}$ [$\text{kg}/(\text{m}^2 \cdot \text{s})$] through the material boundary exposed to the liquid is the time derivative of W . Since a sharp wet front is approximated, the flow in the entire saturated region is equal to the boundary flow, i.e.

$$g = g_{x=0} = \frac{dW}{dt} = \frac{A}{2\sqrt{t}} \quad (6)$$

The sorption coefficient, A and the penetration coefficient, B , is determined from capillary water uptake test. During the test specimens are absorbing water from one side at the same time as the specimen weight are measured at regular intervals. The amount of absorbed water (W) is registered by weighing the specimen at regular intervals. The result can be expressed in a graph where the amount of absorbed water per square meter plotted as a function of the square root of time, see Figure 4. The sorption coefficient and penetration coefficient can then be calculated as:

$$A = \frac{W_{cap}}{\sqrt{t_c}} \quad (7)$$

$$B = \frac{h}{\sqrt{t}} \quad (8)$$

where h is the height of the specimen [m].

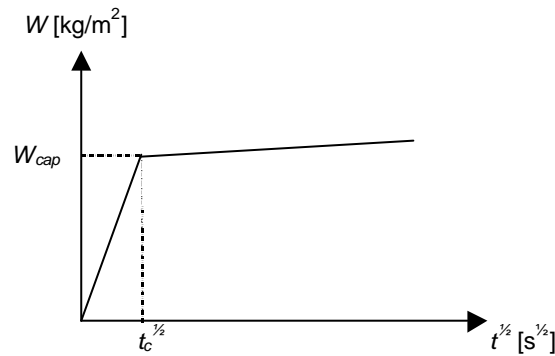

Figure 4 Typically result of a capillary water uptake test.

A basic weakness of the simple capillary suction theory is the assumption that moisture transport involves a moving boundary. Another weakness is that it fails to recognize that there will always be a combination of liquid and vapor transport and a moisture front that is not completely sharp. Consequently, other theories have been developed.

Capillary flow is driven by the pressure difference in the pore water, which in turn mainly is caused by the pressure difference across a meniscus. Thus the driving potential can be expressed as the pressure gradient across the meniscus, i.e. the suction s . One approach to capillarity is consequently to use Darcy's law with the suction s [Pa] as the driving potential:

$$g = I_m \frac{\partial s}{\partial x} \quad (9)$$

where I_m is the moisture conductivity [kg/(m·s·Pa)] that is a function of the suction.

3.2.4 Total moisture transport: Isothermal conditions

When calculating moisture distribution, it is advantageous to have only one equation with a single transport coefficient that describes the total moisture transport in both vapor and liquid phases (i.e. both vapor diffusion and capillary transport). One reason for this is that it is difficult to distinguish between vapor and liquid transport when measuring moisture transport

coefficients. For materials in which there is no temperature gradient, such a formulation of the transport equation is possible, as shown below.

If the assumptions in equations 1 and 9 are valid (i.e. the moisture flow is linearly proportional to the gradient of vapor pressure and suction), the total transport can be described (here, in one dimension) by:

$$g = -\mathbf{d}_p \frac{\partial p_v}{\partial x} + \mathbf{l}_m \frac{\partial s}{\partial x} \quad (10)$$

At local equilibrium a relation exists between p_v and s , as well as among all of the following moisture state variables: vapor content v [kg/m^3], vapor pressure p_v [Pa], relative humidity \mathbf{f} , pore suction s [Pa], moisture content of evaporable water mass by mass u [kg/kg], and moisture content of evaporable water mass by volume w [kg/m^3]. Hence, at isothermal conditions there will be only one independent state variable, i.e. any one of v , p_v , \mathbf{f} , s , u or w . The relation between p_v and s is given by combining Kelvin's equation with the Laplace equation:

$$\ln\left(\frac{p_v}{p_s}\right) = -\frac{sM_w}{RT \mathbf{r}_w} \quad (11)$$

where the index s refer to saturation, R is the gas constant ($8.314 \text{ J}/(\text{mol}\cdot\text{K})$), T is the temperature [K], M_w is the molar weight of water ($0.018 \text{ kg}/\text{mol}$), and \mathbf{r}_w is the density of water [kg/m^3].

Equation 10 can thus be rewritten for isothermal conditions:

$$\frac{\partial s}{\partial x} = \frac{\partial s}{\partial p_v} \frac{\partial p_v}{\partial x} = -\frac{RT \mathbf{r}_w}{M_w} \frac{1}{p_v} \frac{\partial p_v}{\partial x} \quad (12)$$

This leads to:

$$g = -\mathbf{d}_p \frac{\partial p_v}{\partial x} - \mathbf{l}_m \frac{RT \mathbf{r}_w}{M_w} \frac{1}{p_v} \frac{\partial p_v}{\partial x} = -D_{tot} \frac{\partial p_v}{\partial x} \quad (13)$$

where the new merged moisture diffusivity D_{tot} is:

$$D_{tot} = \mathbf{d}_p + \mathbf{l}_m \frac{RT \mathbf{r}_w}{M_w} \frac{1}{p_v} \quad (14)$$

Generally equation 13 can be written:

$$g = -D_j \frac{\partial \mathbf{j}}{\partial x} \quad (15)$$

where D_j is the moisture diffusivity, which is dependent on the moisture content, and \mathbf{j} is any of the moisture state variables v , p_v , \mathbf{f} , s , u , or w .

Transient moisture distribution in a concrete structure can be predicted by mass balance, i.e. in our case moisture balance. Moisture balance in one dimension requires:

$$\frac{\partial w}{\partial t} = \frac{\partial}{\partial x} \left(D_j \frac{\partial \mathbf{j}}{\partial x} \right) - \frac{\partial w_n}{\partial t} \quad (16)$$

where w_n [kg/m³] is the moisture content of non-evaporable water. The second term on the right hand side gives thus the chemical fixation of water by the binder. This term will be zero when the hydration comes to an end.

Equations 15 and 16 are valid at isothermal conditions and at local equilibrium since there are unique relations among all state variables. It is not obvious, however, that there is a local equilibrium in the material in transient cases. The rate of the phase change in nonequilibrium thermodynamics is considered to be proportional to the difference between the thermodynamic potentials of each phase [9]. In transient transport processes the liquid and vapor phases will consequently not be in local equilibrium as, for example, Kelvin's equation presupposes.

The advantage of equations 15 and 16 is that the potential \mathbf{j} can be chosen to fit a special application or measurement. Relative humidity or moisture content is often practical choices since these potentials are directly measurable. But there are also disadvantages to using an arbitrary potential \mathbf{j} . For example, the equation is not pedagogically clear, so one might be led to erroneously believe that \mathbf{j} is the correct driving potential.

3.2.5 Total moisture transport: Non-isothermal conditions

In wall structures, bridge decks exposed to solar radiation, and other structures with large temperature gradients, the temperature gradient itself will impel moisture transport.

If the temperature gradient is to be taken into account, there will be two independent state variables. In this case, the simplification done in the previous section is not possible (i.e. the vapor and liquid flows in equation 10 must stay separate):

$$g = -\mathbf{d}_p \frac{\partial p_v}{\partial x} + \mathbf{l}_m \frac{\partial s}{\partial x} \quad (17)$$

All other state variables are known functions of p_v and s . Here the transport coefficients \mathbf{d}_p and \mathbf{l}_m are functions of the two state variables used (i.e. \mathbf{d}_p and \mathbf{l}_m are functions of both s and p_v). Although the state variables used in equation 17 are the physical determinants of diffusion and liquid flow, any other pair of independent state variables could be used. It is possible to change from one pair of state variables to another pair.

In [10] an overview of the different methods of calculation used is presented. The most commonly used pairs of state variables in these equations are (w, p_v) , (p_v, s) and (w, T) .

3.2.6 Two-phase flow and interaction

In some applications it is desirable to distinguish between liquid flow and vapor flow. For example, dissolved chloride ions are transported by convection in the liquid phase but not in the vapor phase. In order to separate the flow of these two different phases, each phase needs its own equation to describe the transport. Moreover, an equation that describes the balance between the two phases is needed.

If the mathematical formulations describing vapor transport and liquid transport used in equation 1 and equation 9 are correct, the one-dimensional mass balance equations become:

$$\frac{\partial w_v}{\partial t} = \frac{\partial}{\partial x} \left(\mathbf{d}_p \frac{\partial p_v}{\partial x} \right) \quad (18)$$

and

$$\frac{\partial w_\ell}{\partial t} = - \frac{\partial}{\partial x} \left(\mathbf{I}_m \frac{\partial s}{\partial x} \right) - \frac{\partial w_n}{\partial t} \quad (19)$$

Here, w_v is the vapor content mass per volume material [kg/m^3] and w_ℓ is the liquid content mass per volume material [kg/m^3]. The sum of the two phases consequently is the total moisture content w :

$$w = w_v + w_\ell \quad (20)$$

During a water transport process there will always be evaporation or condensation at the water menisci. Thus, there will be a phase transformation between the vapor and liquid phases. This is ignored in equations 18 and 19. The total equations that describe two-phase flow are:

$$\frac{\partial w_v}{\partial t} = \frac{\partial}{\partial x} \left(\mathbf{d}_p \frac{\partial p_v}{\partial x} \right) + \hat{w}_v \quad (21a)$$

and

$$\frac{\partial w_\ell}{\partial t} = - \frac{\partial}{\partial x} \left(\mathbf{I}_m \frac{\partial s}{\partial x} \right) - \frac{\partial w_n}{\partial t} + \hat{w}_\ell \quad (21b)$$

where

\hat{w}_v is a function describing the rate of water transformation from liquid to vapor [$\text{kg}/(\text{m}^3 \cdot \text{s})$];

\hat{w}_ℓ is a function describing the rate of water transformation from vapor to liquid [$\text{kg}/(\text{m}^3 \cdot \text{s})$].

The relation between \hat{w}_v and \hat{w}_ℓ is:

$$\hat{w}_v = -\hat{w}_\ell \quad (22)$$

Consequently, the equations needed to describe the two-phase flow are:

$$\frac{\partial w_v}{\partial t} = \frac{\partial}{\partial x} \left(\mathbf{d}_p \frac{\partial p_v}{\partial x} \right) + \hat{w}_v \quad (23a)$$

$$\frac{\partial w_\ell}{\partial t} = -\frac{\partial}{\partial x} \left(\mathbf{I}_m \frac{\partial s}{\partial x} \right) - \frac{\partial w_n}{\partial t} - \hat{w}_v \quad (23b)$$

Besides these two equations, a third equation describing the phase transformation between the liquid and vapor flow is needed.

$$\hat{w}_v = f \left(w_v, w_\ell, |\text{grad}(w_v)|, |\text{grad}(w_\ell)|, T, \text{pore geometry}, \dots \right) \quad (24)$$

Even though it is sometimes desirable to distinguish between liquid and vapor flow, it is impossible to measure the phase transformation (evaporation and condensation at the water menisci) with the measuring techniques available today. The same is true for the two ‘clean’ transport coefficients \mathbf{d}_p and \mathbf{I}_m . The transport coefficients obtained always describe the total moisture transport, since only the total moisture transport can be measured. Therefore, the coefficients in the separate processes must be estimated. So, the possibility of using equations 23 and 24 is limited. These equations can, however, be of use when parameter studies are done.

3.2.7 Moisture transport above capillary saturation

The above described methods to calculate moisture transport does not cover water transport above capillary saturation. However, the gradual water absorption that occurs above capillary saturation (see Figure 5) is very important since several durability problems, (e.g. frost action) occurs at moisture levels in this range. There is clearly a lack of knowledge about this moisture transport, for very few attempts have been made to describe the process physically and mathematically.

When actual capillary absorption comes to an end, there always is a certain amount of enclosed air in the pore system. It is this enclosed air that prevent frost damages. Thus, the material is not completely saturated. The enclosed air will, however, gradually dissolve in the water and diffuse to larger pores or out of the pore system to the surface of the material, which will lead to slow water absorption above capillary saturation. The rate of this dissolution is proportional to the solubility of air in water, which is in turn proportional to the internal overpressure ΔP [Pa] in the enclosed air. Thus, the rate of gradual water absorption will be proportional to the dissolution rate of air in water and the diffusivity of air in the pore water. An air bubble that becomes enclosed in a coarse pore during the capillary absorption process is exposed to an internal overpressure that is inversely proportional to its radius. The overpressure is given by Laplace equation:

$$\Delta P = \frac{2\mathbf{s}}{r} \quad (25)$$

In equation 25, \mathbf{s} is the surface tension [N/m] and r is the radius of the bubble [m]. The diffusivity of air in the pore water is a function of the pore structures.

According to [11] and [12] one can calculate the water volume V [m³] needed in order to completely dissolve an air bubble of radius r :

$$V = \frac{4\mathbf{p}}{3} \frac{\mathbf{r}_0}{s_a} \left(1 + \frac{P_0}{\Delta P} \right) r^3 \quad (26)$$

where ρ_0 is the density of air [kg/m^3], s_a is the solubility of air [$\text{kg}/(\text{m}^3 \cdot \text{Pa})$] and P_0 is the atmospheric pressure.

Using equations 25 and 26 one can calculate that a water sphere with a radius of $69 \mu\text{m}$ is needed to completely dissolve an air bubble of the radius $10 \mu\text{m}$. Shortly after the end of the capillary process will therefore small air bubbles become water filled. Large air bubbles, on the other hand, will take considerable time to dissolve.

Little is known about this slow water absorption process, and consequently, with the usually used mathematical description of moisture transport, one can only calculate water absorption up to capillary saturation. The fields of application of these descriptions are therefore limited. However, in [11] the long-term water absorption above capillary saturation is examined theoretically and experimentally. A way of modelling this absorption also is proposed in [11]. For reasonably large specimens, water absorption is assumed to take place simultaneously over the specimen body. The degree of saturation over capillary saturation S_a [m^3/m^3] is then defined by:

$$S_a = \frac{V_w - V_{w, \text{cap}}}{V_P - V_{w, \text{cap}}} \quad (27)$$

where V_w is the volume of water in the specimen [m^3]; $V_{w, \text{cap}}$ is the volume of water in the specimen at capillary saturation [m^3]; and V_P is total pore volume [m^3]. The degree of saturation over capillary saturation can possibly be modelled by [12]:

$$S_a = at^b \quad (28)$$

where a and b are constants and t [s] is the time, measured from when capillary saturation is reached. The constant a is a function of the diffusivity of air in the pore system and b is a function of pore size distribution. By using equation 27 and 28 the constants a and b are calculated from a long-term water absorption test. For some concrete, the constants a and b were approximately $6.7 \cdot 10^{-3}$ and 0.26 respectively [11]. For some materials such as concrete, it will take a considerable time, perhaps years, until the absorption stops.

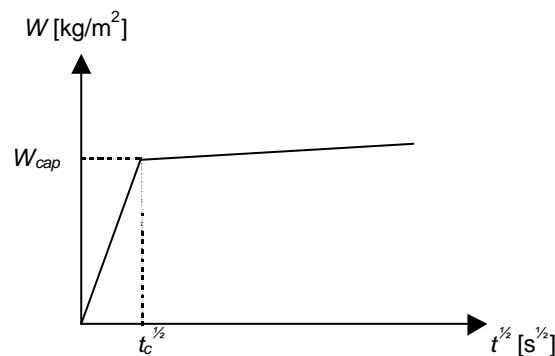

Figure 5 The initial rapid water uptake comes to an end when capillary transport stops. The moisture content continues to increase as a consequence of the air in non-active pores dissolving in the water. This latter process is, however, very slow.

3.2.8 *Methods of determining moisture diffusivity*

As shown above, several different models can be used to describe moisture transport in porous materials. It is important to keep the mathematical model in mind when working with measured data. It should also be noted that the choice of state variables influences the numerical value of the transport coefficients.

Thus, there is a close link between the transport coefficients measured, the theoretical physical model to which they are to be applied, and the potential used.

At isothermal conditions and in the hygroscopic range (up to approximately 98% relative humidity) several well-documented measurement methods are available (see e.g. [13] and [14]). The most frequently used is probably the cup method. For materials with little or no superhygroscopic range (i.e. with pore radii smaller than approximately 50 nm), the cup method alone is sufficient to measure the moisture diffusivity. This is due to the fact that these materials are already water saturated at equilibrium with approximately 98% relative humidity. An example of such a material is concrete with a low water to cement ratio.

Cup method measurements must be supplemented by some other method at high moisture levels. One possibility is to calculate the moisture diffusivity from the relation between the water sorption coefficients and the initial water content in the specimen before testing. This method is presented in detail in [8] and [14]. The moisture diffusivity at high moisture levels can also be determined from moisture profiles at steady state, see [15] and [6]. The most frequently used method is although to determine the moisture diffusivity from transient moisture profiles using Boltzmann transformation or the profile method.

The profiles are measured on specimens that are absorbing liquid water from the boundary, or on specimens subjected to the redistribution process occurring when the absorption process is interrupted. Several different methods of determining transient moisture profiles exist. An overview of these methods is presented in [16].

In order to determine the transport coefficients at non-isothermal condition one must separate moisture flow induced by temperature gradient from flow induced by a gradient in vapor pressure. This is not easily done and up to now stills a relatively unexplored research area. Some attempts has although been done, see e.g. [17].

3.3 **Moisture fixation in porous materials**

Knowledge of moisture fixation is essential when calculating moisture, especially when different materials are to be connected (e.g. a repair material on a deteriorated concrete).

Water can be physically bound in the pores through *adsorption* of water molecules on the surface of the pore or through surface tension effects causing *capillary condensation* of surrounding water vapor or *capillary uptake* of water. Adsorption takes place at low moisture levels and the adsorbed water molecules are bound to the pore surface by van der Waal forces. At equilibrium the amount of adsorbed water per square meter of pore surface is a function of the temperature and the relative humidity of the ambient air. There is never a static condition. As some water molecules leave the pore surface, other water molecules become attached. At equilibrium, the number of molecules leaving is the same as the number becoming bound to the surface. The total number of water molecules on the pore surface, i.e. the thickness of the adsorbed water layer, increases with increasing relative humidity in the pores.

Capillary condensed water molecules are condensed on curved water menisci that are formed in small pores and other narrow spaces. Theoretically there is no upper moisture level for capillary condensation, but normally this phenomenon is assumed to be restricted to the hygroscopic range while capillary water uptake occurs in the superhygroscopic range.

In the hygroscopic range, the relation between the moisture content of the ambient air and the moisture content of the material represents the moisture storage capacity. This relation is given by sorption isotherms. In the superhygroscopic range, the relation between the suction s [Pa] and the moisture content of the material represents the moisture storage capacity. This relation is shown in what are called water retention curves. For cement based materials there is hysteresis between absorption and desorption (i.e., the relations are different, depending on whether equilibrium is reached by absorption or desorption).

In equation 11 the relationship between the relative humidity and the suction is reached by combining Kelvin's equation with the Laplace equation. Thus, it is possible to represent the moisture fixation in both the hygroscopic and the superhygroscopic range with one single relationship with either relative humidity or suction as the moisture storage potential. Using relative humidity as the moisture storage potential will result in a very steep curve in the superhygroscopic range (i.e., the resolution in this region will be poor). At high moisture levels, it is therefore better to choose the suction as the moisture storage potential (i.e., water-retention curves).

3.3.1 Methods of determining the moisture fixation

There are several different methods of measuring moisture storage capacity in the hygroscopic and superhygroscopic range. The classical, and probably most common, method of measuring fixation in the hygroscopic range uses different saturated salt solutions. Specific levels of relative humidity exist above saturated salt solutions in closed climate boxes. By placing samples of a material in boxes with different salt solutions, each one corresponding to different relative humidity, the sorption isotherm can be measured. The method is robust and relative simple, but also quite time-consuming. Depending on the material and the size of the specimen, the experimental time may vary from a month to a year.

Faster methods of measuring sorption isotherms exist. One possibility involves using a twin double microcalorimeter. A detailed account of this method is given in [18] and [19]. Yet another approach to measuring moisture storage capacity in the hygroscopic range involves using a sorption balance, in which a small material sample is weighed as it is exposed to a small airflow with different RH. In [20] these three complementary methods of measuring moisture storage capacity in the hygroscopic range are described, discussed, and compared. A review of other methods of measuring moisture storage capacity in the hygroscopic range can be found in [21].

There is no established method of determining moisture storage capacity in the superhygroscopic range, for saturated salt solutions cover only the hygroscopic range. However, a technique using pressure plate and pressure membrane extractors is gaining acceptance. A standard method for using this technique has existed since 1997 and is set out in Nordtest Standard NT BUILD 481 [22]. The technique is described in detail in [23], in which different methods of presaturating the specimens and handling the equipment are tested and discussed. The lowest moisture levels measurable with the pressure plate and pressure membrane technique overlap the highest moisture levels measurable in the hygroscopic range. This overlapping is studied in [24].

3.4 Calculation of moisture distribution

3.4.1 Transient calculations

With help of the models described above, relevant measured moisture properties, well-defined boundary and initial conditions and some numerical model (e.g. the finite element method (FEM) or the explicit forward difference method (FDM)), the moisture state can be calculated. Normally the formulation in equation 16 is used. A number of general computer programs capable to solve equation 16 and similar partial differential equations are available (also in 2- and 3-dimensions). There also exist programs designed for more specific moisture problems. An example of such case is the initial drying of concrete for which there in Sweden exist an easy to use computer program (TorkaS [25]).

3.4.2 Steady-state moisture flow in one dimension

For the special case of steady-state moisture flow in 1D it is easier to calculate the moisture distribution. Once steady state conditions are reached, it is obvious that the moisture flow in a structure is constant in all sections and over time. Hence, for a structure with a thickness of d , the moisture flow g [$\text{kg}/(\text{m}^2 \cdot \text{s})$] is:

$$g = g(x, t) \quad 0 \leq x \leq d \quad t \geq 0 \quad (29)$$

The flow can then be expressed in accordance with equation 15, i.e.

$$g = -D_j \frac{\partial \mathbf{j}}{\partial x} \quad (30)$$

where D_j is the moisture diffusivity, which is dependent on the moisture content, and \mathbf{j} is any of the moisture state variables v , p_v , f , s , u , or w . If the moisture diffusivity, D_j , would be constant then the distribution of $\mathbf{j}(x)$ through the structure with a thickness of d would be linear for $0 \leq x \leq d$. For a combination of several materials, i.e. repair material on a concrete structure, the distribution of $\mathbf{j}(x)$ through each material would be linear.

However, normally the moisture diffusivity, D_j , is not constant but varies with the moisture content \mathbf{j} , the slope of the $\mathbf{j}(x)$ distribution will be inversely proportional to the moisture diffusivity, $D_j(\mathbf{j}(x))$.

Equation 30 with vapor used as flow potential can be rewritten as:

$$g = \frac{\Delta v}{Z_v} \quad (31)$$

where Z_v [s/m] is the moisture resistance with regard to vapor content. It is obvious that:

$$Z_v = \frac{d_i}{d_v} \quad (32)$$

Provided that Z_v is constant for each layer in a 1D multi layer structure (i.e. repair material on old concrete) the steady-state moisture distribution of vapor content, v , can be calculated:

$$v_j = v_A + \frac{\sum_{i=1}^j Z_i}{Z_{tot}} (v_B - v_A) \quad (33)$$

where v_A and v_B [kg/m^3] are the vapor content on respective side of the structure, Z_{tot} [s/m] is the total moisture resistance with regard to vapor content of the structure and Z_i [s/m] is the moisture resistance of layer i , see Figure 6.

If the moisture diffusivity, and consequently also the moisture resistance, is not constant within each type of material, the material can be divided in several layers. If the vapor content and thus also the moisture resistance is assumed to be constant within each layer, the vapor distribution can be calculated iterative. A vapor distribution is estimated from which the moisture resistance for each layer can be obtained. A new vapor distribution can thereafter be calculated using equation 33. This process is repeated until a solution converges.

If required the method described above also can be used calculating the distribution of vapor pressure instead of vapor content. The vapor content v [kg/m^3] is then replaced with vapor pressure p_v [Pa] and the moisture resistance with regard to vapor content Z_v [s/m] is replaced with the moisture resistance with regard to vapor pressure, Z_p [$\text{m}^2 \cdot \text{s} \cdot \text{Pa}/\text{kg}$] in equation 33.

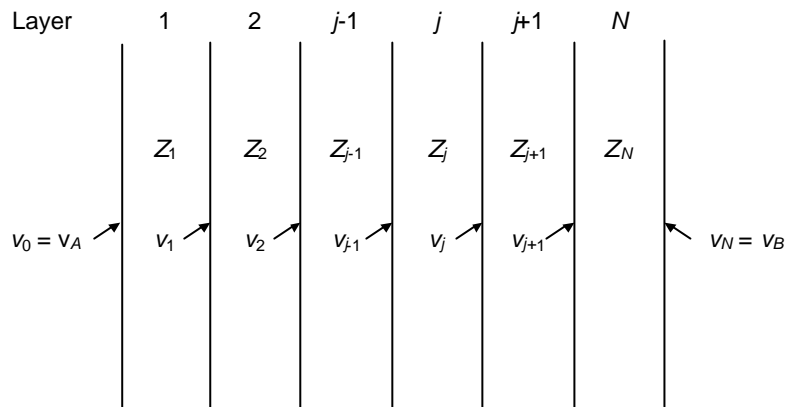

Figure 6 Structure consisting of several layers.

3.5 Obstacles

The moisture condition in repaired concrete structures are obvious not easy to predict quantitative. The accuracy of calculated moisture distributions will only be as accurate as the accuracy of the model used and the input data (moisture properties) available. For repaired structures it is difficult to calculate and anticipate the moisture state due to the complexity of the system consisting of several different materials, often with unknown moisture properties. The boundary conditions often are difficult to define. Furthermore, the repair often is subjected rain and thereby to very high moisture levels by which there exist very little measured moisture properties. The mathematical description of moisture transport at high moisture levels is also not very well investigated. If the repair is exposed for solar radiation there might be very large temperature gradients causing moisture transport. This transport phenomena with related transport properties is neither well known.

Calculations normally assume perfect hydraulic contact between the materials involved. However, results presented in [26] show that imperfect hydraulic contact were obtained between autoclaved aerated concrete and mortar. If this also is the case for repair material on

concrete is unknown, but it seems likely that the assumption of perfect hydraulic contact not always is appropriate.

Consequently, there is still a lack of knowledge in order to make reliable moisture calculations on repaired structures. Further research is therefore needed, especially concerning moisture transport at non-isothermal conditions, at high moisture levels and the influence of the interface.

A quantitative assessment ought to be possible for simple cases such as moisture flow in one dimension without temperature gradients. The input required for such calculation is:

1. Moisture diffusivities for both the substrate and repair material.
2. Sorption isotherms for both the substrate and repair material (showing hygroscopic moisture fixation).
3. Water retention curves for both the substrate and repair material (showing moisture fixation at high moisture levels).
4. Boundary conditions, i.e. environmental conditions and microclimate.

In the hygroscopic range measured moisture diffusivities and sorption isotherms are available for several different concrete qualities, see e.g. [6], [7] and [13]. But knowledge on moisture flow properties at high moisture levels is lacking to a large extent. Accurate prediction of the moisture profile during water absorption is thus still difficult due to the lack of data for moisture flow at high moisture levels. For many types of repair material is the lack of moisture diffusivities, sorption isotherms and water retention curves even larger. A large effort in collecting moisture properties using is thus needed.

Hence, it is very difficult to calculate the moisture state in a repaired structure. A calculation of the moisture state will therefore, at best, only give the supposed magnitude of the moisture content. Calculations and parameter studies can although give valuable information when different alternatives are compared.

4 REFERENCES

- [1] Nilsson, L.-O., Peterson, O. (1983), “*Alkali-silica reactions in Scania, Sweden – A moisture problem causing pop-outs in concrete floors*”, Report TVBM-3014, Division of Building Materials, Lund University.
- [2] Pettersson, K. (1996), “*Service Life of Concrete Structures – In saline environment*”, CBI Report 3:96, Swedish Cement and Concrete Research Institute, Stockholm.
- [3] Tuutti, K. (1982), “Corrosion of steel in concrete”, CBI Research Fo 4:82. Swedish Cement and Concrete Research Institute, Stockholm.
- [4] Fagerlund, G. (1977) “The critical degree of saturation method of assessing the freeze/thaw resistance of concrete”, *Materials and Structures*, Vol. 10, No. 58.
- [5] Fagerlund, G. (1977) “The international cooperative test of the critical degree of saturation method of assessing the freeze/thaw resistance of concrete”, *Materials and Structures*, Vol. 10, No. 58.
- [6] Hedenblad, G. (1993), “*Moisture permeability of mature concrete, cement mortar and cement past*”, Report TVBM-1014, Division of Building Materials, Lund Institute of Technology, Lund, Sweden.
- [7] Hedenblad, G. (1996), “*Material properties for calculations of moisture transport*” (in Swedish), Report T19:1996, Swedish Council for Building Research, Stockholm, Sweden.
- [8] Janz, M. (2002), “Moisture diffusivities evaluated at high moisture levels from a series of water absorption tests”, *Materials and Structures*, Vol. 35, pp 141-148.
- [9] Daian, J.-F. (1989), ‘Condensation and isothermal water transfer in cement mortar: Part II – Transient condensation of water vapour’, *Transport in porous media*, vol. 4, pp. 1–16.
- [10] Künzle, H. M. (1995), ‘*Simultaneous heat and moisture transport in building components: One- and two-dimensional calculation using simple parameters*’, IRB Verlag, Stuttgart.
- [11] Fagerlund, G. (1993), ‘*The long time water absorption in the air-pore structure of concrete*’, Report TVBM-3051, Division of Building Materials, Lund Institute of Technology.
- [12] Fagerlund, G. (1995), ‘The required air content of concrete’, *Proceedings of the International workshop on Mass-Energy Transfer and Determination of Building Components – Models and Characterisation of Transfer Properties*, pp 591-609, Paris 9-11 January.
- [13] Nilsson, L.-O. (1980), ‘*Hygroscopic moisture in concrete: Drying measurements and related material properties*’, Report TVBM-1003, Division of Building Materials, Lund Institute of Technology, Lund, Sweden.
- [14] Janz, M. (1997), ‘*Methods of measuring the moisture diffusivity at high moisture levels*’, Report TVBM-3076, Division of Building Materials, Lund Institute of Technology.
- [15] Arfvidsson, J. (1994), ‘*Isothermal moisture transport in porous materials: Calculation and evaluation of material data*’ (in Swedish), Report TVBH-1007, Division of Building Physics, Lund Institute of Technology, Lund, Sweden.
- [16] Janz, M. (2000), ‘*Moisture transport and fixation in porous materials at high moisture levels*’, Report TVBM 1018, Division of Building Materials, Lund Institute of Technology.

- [17] Krus, M. (1995), '*Moisture transport and storage coefficients of porous mineral building materials. Theoretical principles and new test methods*' (in German), der Fakultät Bauingenieur- und Vermessungswesen der Universität Stuttgart.
- [18] Wadsö, I. and Wadsö, L. (1996), 'A new method for determination of vapour sorption isotherms using a twin double microcalorimeter,' *Thermochimica acta*, vol. 271, pp. 179–187.
- [19] Wadsö, I. and Wadsö, L. (1997), 'A second generation twin double microcalorimeter: Measurements of sorption isotherms, heats of sorption and sorption kinetics,' *Journal of thermal analysis*, vol. 49, pp. 1045–1052.
- [20] Johannesson, B. and Janz, M. (2002), 'Test of four different experimental methods to determine sorption isotherms', *Journal of Materials in Civil Engineering*, Vol. 14, No. 6, pp. 471 – 477.
- [21] Wadsö, L. (1997), 'A review of methods to measure sorption isotherms and heats of sorption', Paper presented at *International conference on wood–water relations*, Copenhagen, 16–17 June.
- [22] Nordtest Standard. (1997), '*Retention curve and pore size distribution*', NT BUILD 481.
- [23] Janz, M. (2001), 'Technique for Measuring Moisture Storage Capacity at High Moisture Levels', *Journal of Materials in Civil Engineering*, Vol. 13, No. 5, pp. 364 – 370.
- [24] Janz, M. and Johannesson B. F. (2001), 'Measurement of the moisture storage capacity using sorption balance and pressure extractors', *Journal of Thermal Envelope and Building Science*, Vol. 24, No. 4, pp. 316 – 334.
- [25] Hedenblad, G. and Arfvidsson, J. "TorkaS", Computer program available on the web: www.fuktcentrum.lth.se.
- [26] Qiu, X., Haghghat, F. and Kumaran, M. K. (2003) "Moisture transport across interfaces between autoclaved aerated concrete and mortar", *Journal of Thermal Envelope & Building Science*, Vol. 26, No. 3, pp. 213-236.

APPENDIX 2

CARBONATION AFTER CONCRETE REPAIR

CONTENTS	Page
1 BACKGROUND	73
3 THE PROBLEM	73
3.1 Addition of a repair material at the surface of the original concrete	74
3.2 Surface treatment and surface cover	75
4 REQUIRED INPUT	76
5 THE PROBLEM FORMULATION	77
6 CARBONATION AFTER REPAIR – A SIMPLE TOOL	79
6.1 Assumptions	79
6.2 Input data	79
6.3 Evaluation step 1: Prediction of moisture condition	80
6.4 Evaluation step 2: Carbonation of the repair material	80
6.5 Evaluation step 3: Continued carbonation of the original, repaired concrete	80
6.6 Summary	81
6.7 Limitations	81
7 REFERENCES	81
ADDENDUM –Derivation of equations [1] -[4]	82

1 Background

Repair of a concrete structure may aim at delaying a continuing carbonation process that still has not reached the reinforcement. Two typical cases can be identified:

1. Addition of a cementitious repair material at the surface of the original concrete, preventing further carbonation of the original concrete until the repair material has been fully carbonated.
2. Surface treatment and surface cover, changing the resistance to diffusion of carbon dioxide

This paper aims at presenting the content of the problem and required input for quantifying the effect of a repair method. A simple tool to use for evaluation is also presented.

2 Objective

The objective of an evaluation tool for carbonation after concrete repair is to be able to predict the changes in the future carbonation process caused by a repair. With such a tool it would be possible to quantitatively evaluate how much the service-life is prolonged because of a repair and to estimate the required extent of a repair to achieve a certain prolongation of the service-life.

The paper takes carbonation as an important example but the same approach could be utilized for any other gas transport, such as oxygen to a reinforcement corrosion process.

3 The Problem

Before repair the original concrete has a certain depth of carbonation and a certain concentration profile of carbon dioxide. An example is shown in Figure 1.

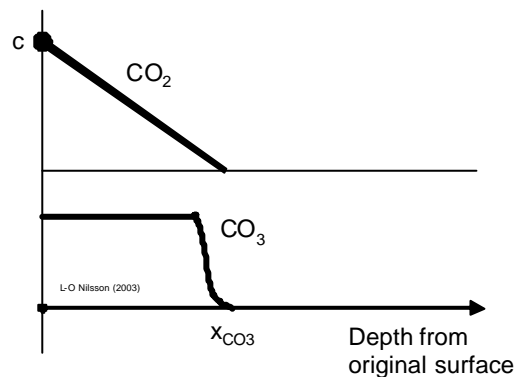

Fig. 1 The profiles of calcium carbonates and carbon dioxide before repair

The carbonation depth is the response by the original concrete to environmental actions during service, up to the point of inspection. It follows from the type, duration and magnitude of the environmental actions and the properties of the concrete. In principal, a thorough inspection and measurements of depth of carbonation and moisture can be utilized to determine, or at least estimate, the carbon dioxide transport properties of the original concrete and the previous environmental actions.

A repair method involving adding a repair material or surface cover may change the resistance to diffusion of carbon dioxide, the future moisture distribution and add a new

resistance to carbonation through additional carbonatable material. The two typical cases are presented in the next sections, original ideas from Fagerlund (1988) /1/.

3.1 Addition a repair material at the surface of the original concrete

A natural repair to slow down a carbonation process would be to keep the original concrete, with its carbonate content, but adding a cementitious repair material at the surface, see Figure 4.

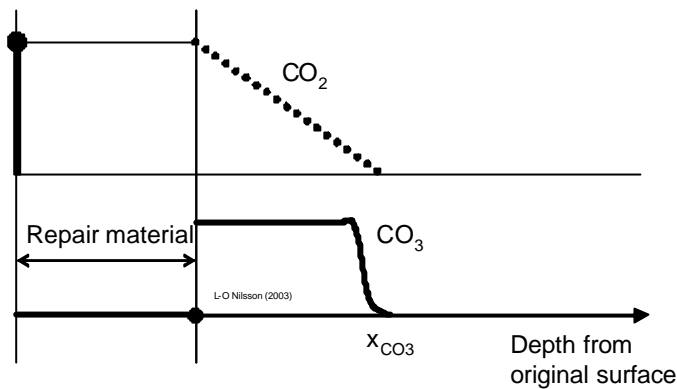

Fig. 2 The profiles of carbonate and carbon dioxide directly after repair when a repair material has been added to the surface of the original concrete.

Then, after the repair the carbonation in the original concrete will cease to penetrate further into the concrete. Instead, carbon dioxide will have to penetrate the outer surface, carbonating the repair material.

The profiles of carbon dioxide and carbonates through the repair material and the original concrete, at some time after repair, will look like the ones in Figure 3. The carbonation process occurs in the repair material only.

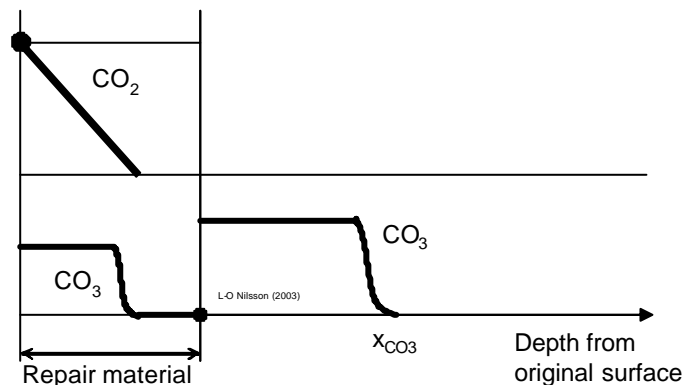

Fig. 3 The distributions of CO_2 and carbonate at some time after repair, when a repair material has been added to the surface of the original concrete.

After further time, the repair material has been fully carbonated, but offers some additional resistance to diffusion of carbon dioxide. Then the old carbonation front will continue to penetrate inwards; the original concrete will start to carbonate again, see Figure 4.

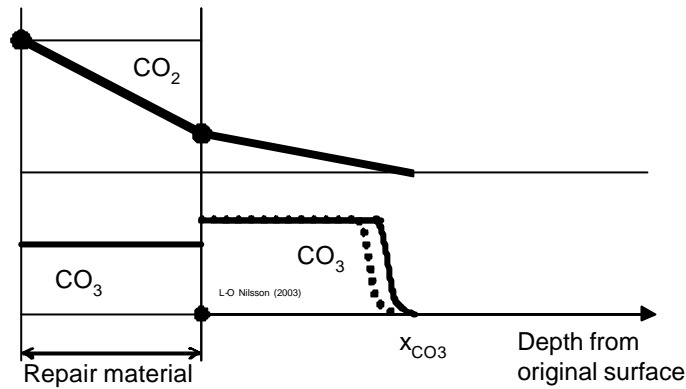

Fig. 4 The distributions of CO_2 and carbonate at further time after repair, when the repair material has been fully carbonated and the original concrete are carbonating again

Eventually, the carbonation front will reach the reinforcement, but the process has been significantly delayed, adding more remaining service-life to the original concrete.

3.2 Surface treatment and surface cover

If the only repair is a surface cover or a surface treatment, depending on its properties, could change the rate of carbonation after the repair. A short time after the repair, if the surface protection adds some significant resistance to diffusion of carbon dioxide, the concentration of carbon dioxide close to the surface of the original concrete will be much lower, cf. Figure 5.

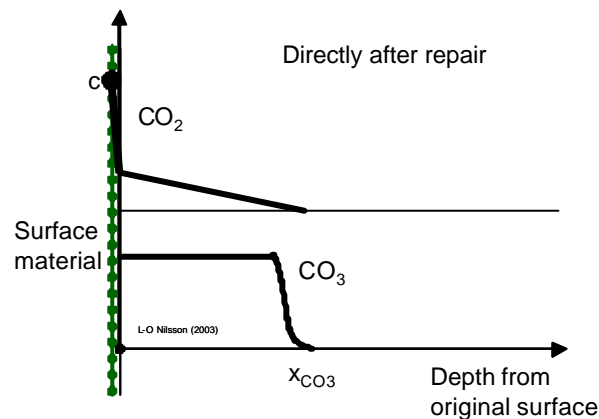

Fig. 5 The profiles of carbon dioxide and carbonates directly after repair when a surface cover or treatment has been added to the surface of the original concrete.

The carbonation process will continue, but at a lower rate, depending on how much diffusion resistance is contributed by the surface cover, see Figure 6.

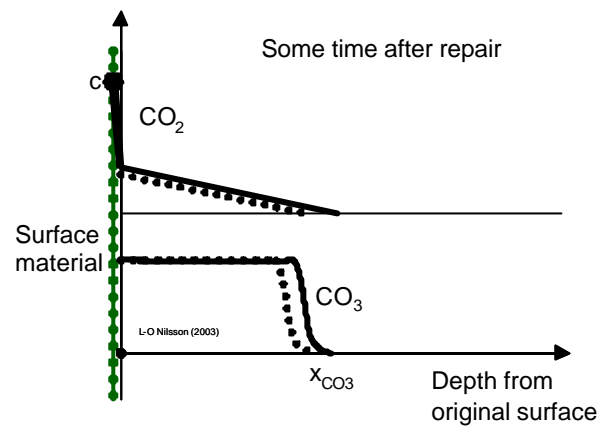

Fig. 6 The distribution of carbon dioxide and carbonates at some time after repair, when a surface cover or treatment has been added to the surface of the original concrete.

Eventually, the carbonation front will reach the reinforcement, but the process has been delayed, adding more remaining service-life to the original concrete.

4 Required input

The relevant content of an evaluation tool for the rate of the carbonation process after repair depends on the available input data for the original concrete and the repair material. The more relevant information that is available, the better prediction could be made and, consequently, the more sophisticated evaluation tool could be utilized. A minimum required set of input data is

1. the depth of carbonation in the original concrete,
2. the carbon dioxide binding properties and diffusion coefficient for CO_2 of the repair material,
3. the exposure time for carbonation of the original concrete; if not known, the carbon dioxide binding properties and diffusion coefficient for CO_2 of the original concrete,

These input data could be enough for predicting the carbonation process after a repair of a concrete structure. A more correct prediction, however, requires some additional input data to predict the future moisture (and temperature) distribution after repair. This is presented in a separate document as an evaluation tool for moisture distributions after concrete repair, Janz (September 2003) /2/.

5 The Problem formulation

The two typical cases presented in section 3 can actually be condensed into one mathematical problem, see Figures 7 and 8. The original concrete has a depth of carbonation x_1 , from carbonation during an exposure time of t_1 (if known).

The original concrete is combined with a repair material L at time t_1 , having a zero carbonate content. After repair, the repair material will start to carbonate, cf. Figure 7. The original concrete has bound an amount of carbon dioxide corresponding to a_0 . The carbon dioxide binding properties of the repair material corresponds to a_L .

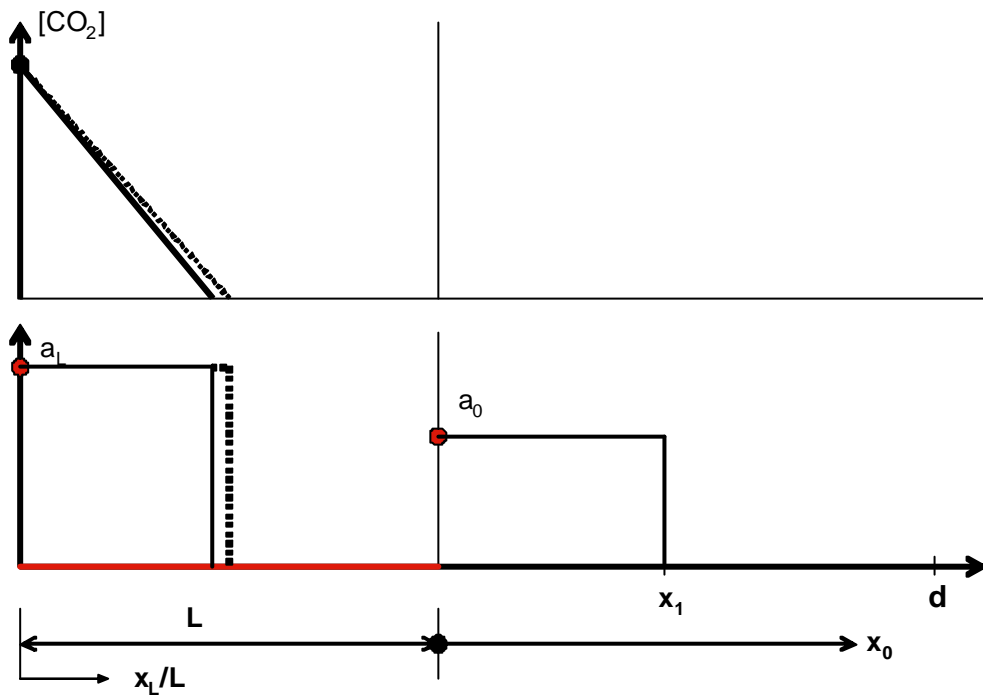

Fig. 7 A mathematical formulation of the carbonation of the repair material at some time after a repair with a repair material added to the original concrete surface.

After a certain time the repair material has been fully carbonated. Then the original concrete will continue to carbonate again, but at a slower rate, cf. Figure 8.

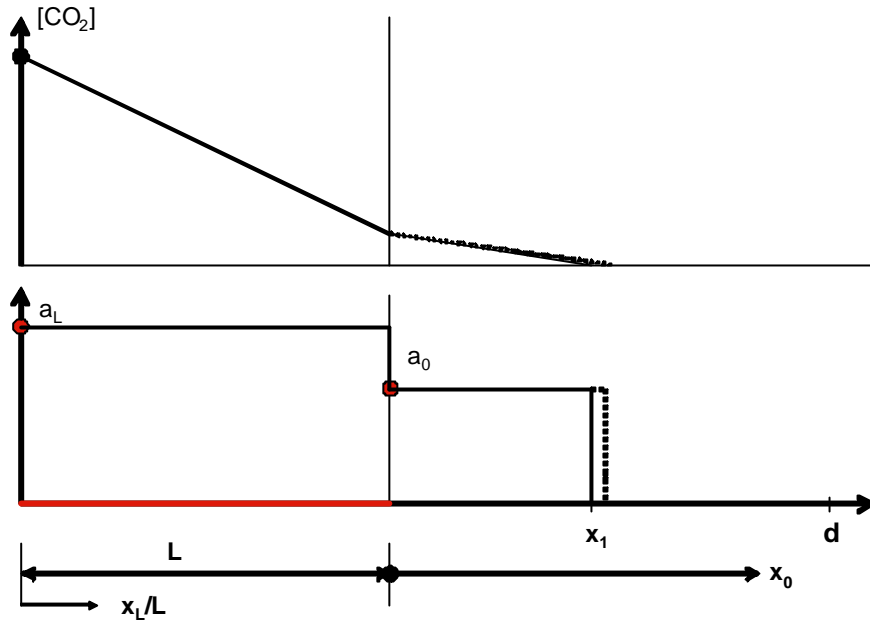

Fig. 8 A mathematical formulation of the carbonation process after the repair material is fully carbonated, or the repair material has no carbonatable material, and the original concrete continues to carbonate.

The carbonation processes will then proceed as in Figure 9, in the various steps.

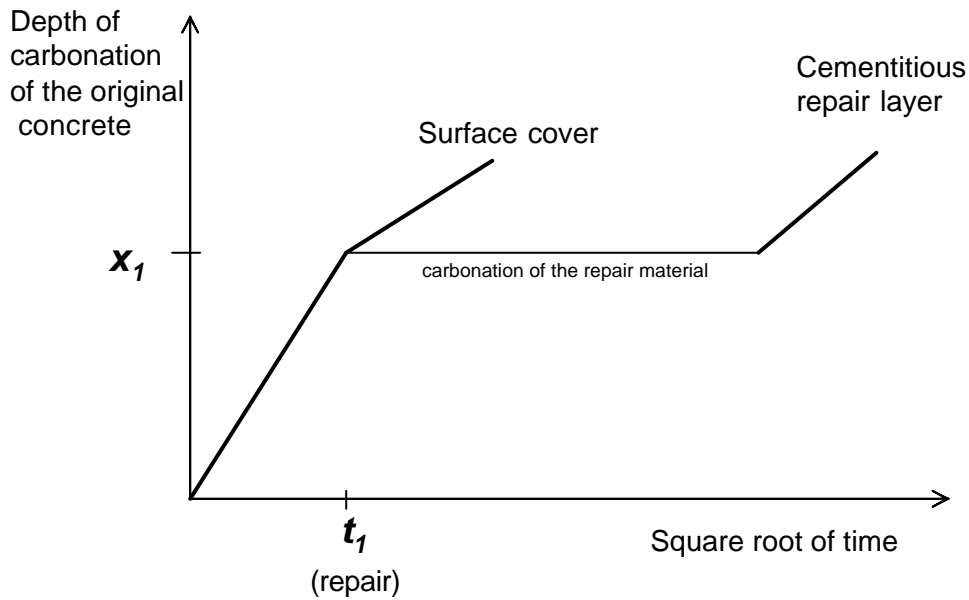

Fig. 9 The carbonation process in the original concrete before and after repair, depending on the type of repair material. After /1/

6 Carbonation after repair - A simple tool

For demonstration of the possibilities, the problem formulated in chapter 5 has been solved for the two steps, carbonating the repair material and continuous carbonation of the original concrete after repair and full carbonation of the repair material.

6.1 Assumptions

The carbonation process is calculated by a simple diffusion/reaction model, from a diffusion of carbon dioxide to the carbonation front where all CO_2 is consumed, cf. Figures 7 and 8. The diffusion process is described by Fick's 1st law of diffusion, with a diffusion coefficient D for CO_2 . The diffusion coefficient is moisture dependent, $D(RH)$, i.e. the wetter the cover, the slower the diffusion. Examples of the moisture dependency are shown in Figure 10.

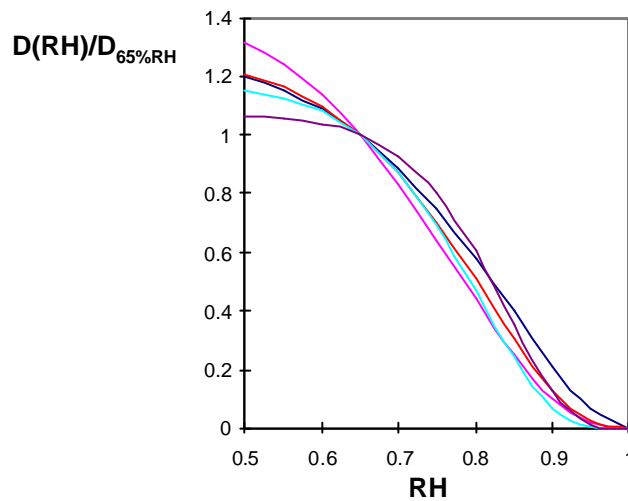

Fig. 10 The moisture dependency of the gas diffusion coefficient. From /3/

6.2 Input data

For the evaluation, a number of data must be available:

From inspection and assessment

1. The depth of carbonation x_1 of the original concrete at the time of repair.
2. If possible, the duration of the exposure t_1 .
3. The previous and future concentration c of carbon dioxide in the surrounding environment.
4. The (average) relative humidity RH_0 of the carbonated layer of the original concrete.
5. The diffusion coefficient for the original concrete D_0 .
6. The carbon dioxide binding capacity a_0 of the original concrete.
7. The cover thickness for the reinforcement d .

From testing the repair material

8. The thickness of the repair material L .
9. The diffusion coefficient for the repair material D_L .
10. The carbon dioxide binding properties of the repair material a_L . A surface cover, with no cementitious content, which can react with carbon dioxide, has an a_L equal to 0.

Data 5) and 6) can be evaluated from 1), 2) and 3), if missing:

$$\frac{D_0}{a_0} = \frac{x_1^2}{2 \cdot t_1 \cdot c} = \frac{K_0^2}{2c} \quad [1]$$

6.3 Evaluation step 1: Prediction of moisture conditions

First the moisture conditions of the repair material and the original concrete, after repair, must be predicted. This is done with the Evaluation tool for moisture /2/.

From the predicted moisture conditions, the average relative humidity of the repair material \overline{RH}_L and the cover of the original concrete \overline{RH}_0 are evaluated.

6.4 Evaluation step 2: Carbonation of the repair material

The time to fully carbonate the repair material is estimated from, /1//3/

$$t_L = \frac{L^2 \cdot a_L}{2 \cdot \overline{D}_L(RH_L) \cdot c} \quad [2]$$

6.5 Evaluation step 3: Continued carbonation of the original, repaired concrete

The remaining service-life, once the repair material is fully carbonated, can be derived from

$$t_{d-x_1} = \frac{(d + L_{eq})^2 - (x_1 + L_{eq})^2}{2 \cdot \overline{D}_0(RH_2) \cdot c / a_0} = \frac{(d + L_{eq})^2 - (x_1 + L_{eq})^2}{K_0^2 \cdot k_{RH}} \quad [3]$$

where k_{RH} is the moisture dependency of the gas diffusion coefficient, cf. Figure 10. Note that the relative humidity RH_2 of the original concrete now may be different from the originally RH_0 .

The “equivalent thickness” L_{eq} of the repair material can be evaluated from the testing of the repair material, its thickness L and the diffusion coefficient D_0 of the original concrete,

$$L_{eq} = L \frac{\overline{D}_0(RH_2)}{\overline{D}_L(RH_L)} \quad [4]$$

Consequently, the equivalent thickness of the repair material depends not only on the properties and thickness of the repair material but also on the properties of the original concrete and how the new material combination change the future moisture conditions!

6.6 Summary

The various steps in the evaluation are shown in Figure 11. The residual service-life of the repaired structure will be

$$t_d - t_1 = t_L + t_{d-x_1} \quad [5]$$

that can be calculated from Equations [1] – [4].

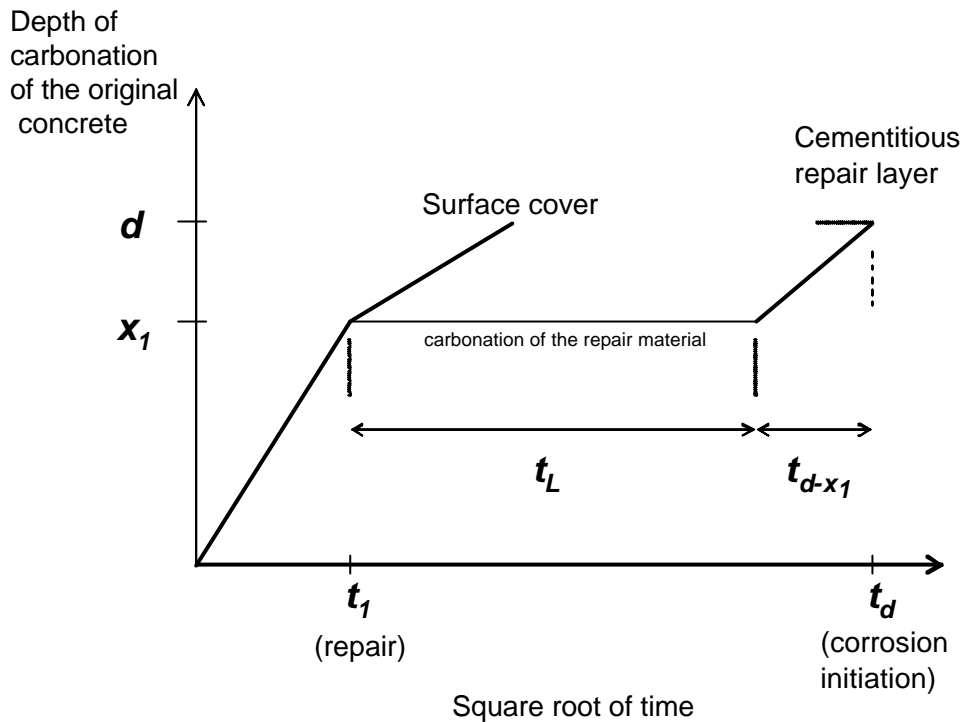

Fig. 11 The carbonation process in the original concrete before and after repair, depending on the type of repair material. After /1/

6.7 Limitations

The type of predictions like the ones shown in chapter 5 should not be regarded as too accurate! Prediction of carbonation still is not an “exact science”, with true, absolute numbers for penetration depths after a certain time. The numbers should be good estimates, however.

7 References

/1/ Fagerlund, G (1988). *The service-life of the repaired structure* (in Swedish), section 2.4 of *The Concrete Hand Book. Repair*. Svensk Byggtjänst, Stockholm 1988.

/2/ Janz, M (2003) *Moisture balance at the interface between repair material and concrete*. Draft 1, September 2003, CBI, Stockholm

/3/ CEB TG 5.1/2 (1997) *New Approach to Durability Design*, CEB Bulletin No 238, Lausanne 1997

ADDENDUM – Derivation of Equations [1] –[4]

Equation [1]

The carbonation process can be described as a combination of diffusion of CO_2 to the carbonation front, at a depth of x_{CO_3} , and the carbonation reaction at that front. During a small time interval dt , the front moves a small distance dx_{CO_3} .

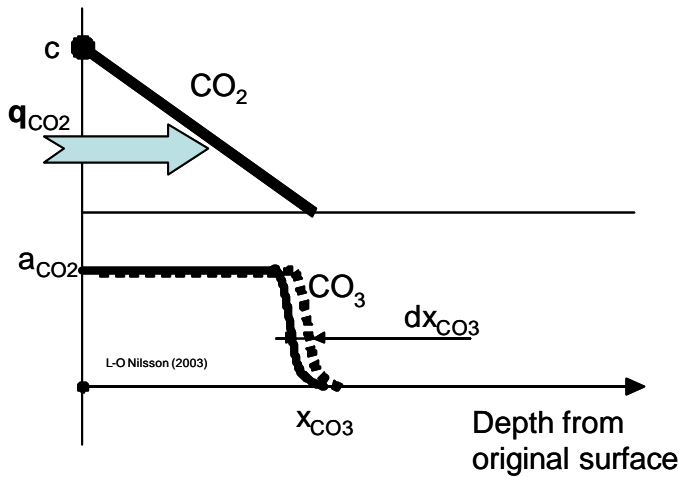

The flux q_{CO_2} to the front will be diffusion through the carbonated layer with a thickness of x_{CO_3} and a concentration difference of $c-0$. The concentration gradient is then c/x_{CO_3} . With an average diffusion coefficient $D_0 = \overline{D_{\text{CO}_2}}$ for the carbonated concrete, the flux will be

$$q_{\text{CO}_2} = \overline{D_{\text{CO}_2}} \cdot \frac{c}{x_{\text{CO}_3}} \quad [\text{kg CO}_2/(\text{m}^2\text{s})] \quad [\text{a}]$$

The carbon dioxide reaching the front will react with the calcium oxide to form more carbonate. The amount of bound carbon dioxide will be $a_0 \cdot dx_{\text{CO}_3}$, where a_0 is the carbon dioxide binding capacity of the original concrete, in $[\text{kg CO}_2/\text{m}^3]$. The transported amount of carbon dioxide, during a time step dt , must be equal to the amount of bound carbon dioxide

$$q_{\text{CO}_2} \cdot dt = D_0 \cdot \frac{c}{x_{\text{CO}_3}} \cdot dt = a_0 \cdot dx_{\text{CO}_3} \quad [\text{kg CO}_2/\text{m}^2] \quad [\text{b}]$$

Integrating this expression, between $t=0$ to t_1 and $x_{\text{CO}_3}=0$ to x_1 will give the depth of carbonation

$$x_1 = \sqrt{\frac{2D_0 \cdot c}{a_0}} \cdot \sqrt{t_1} = K_0 \cdot \sqrt{t_1} \quad [\text{b}]$$

or, rearranged, Equation [1]

$$\frac{D_0}{a_0} = \frac{x_1^2}{2 \cdot t_1 \cdot c} = \frac{K_0^2}{2c} \quad [\text{1}]$$

Equation [2]

The original concrete is combined with a repair material L at time t_1 , having a zero carbonate content. After repair, the repair material will start to carbonate. The carbon dioxide binding properties of the repair material corresponds to a_L .

The time t_L to fully carbonate the repair material is estimated from equation [1], simply by replacing a_0 with a_L , x_1 with L and D_0 with D_L , considering that the average CO_2 -diffusion coefficient for the repair material may be moisture dependent, i.e. $D_L = \overline{D_L}(RH_L)$. That will give equation [2]

$$t_L = \frac{L^2 \cdot a_L}{2 \cdot \overline{D_L}(RH_L) \cdot c} \quad [2]$$

RH_L is the average state of moisture in the repair material.

Equation [3] and Equation [4]

The remaining service-life, once the repair material is fully carbonated, can be derived from describing the carbonation process in a similar way.

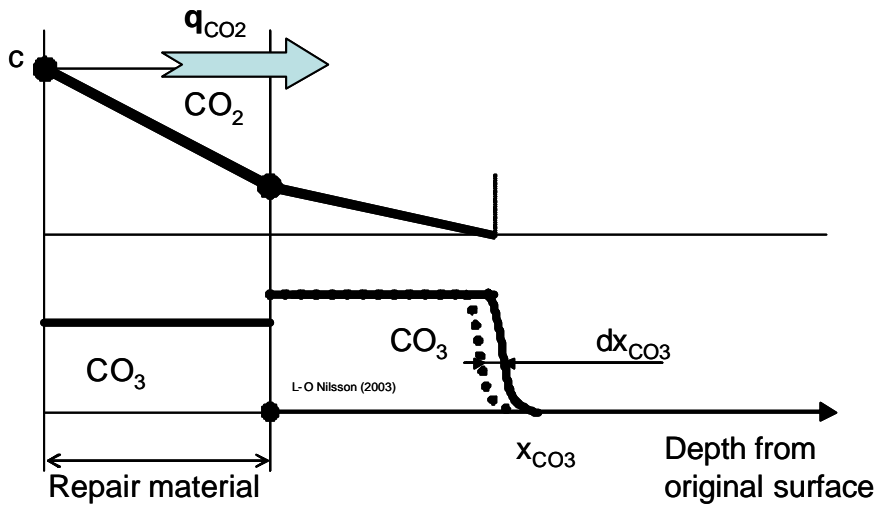

Now the “resistance” R to diffusion of carbon dioxide, between the outer surface of the repair material and the carbonation front in the original concrete will be the sum of the resistances of the repair material, with a thickness L , and the carbonated layer in the original concrete, with a thickness x_{CO_3} . The diffusion resistance R of a layer with a thickness Dx and a diffusion coefficient D will be $R=Dx/D$. The flux q will be Dc/R . Since resistances can be added, the amount of carbon dioxide diffusing through the repair material and the carbonated part of the original concrete, during a small time interval dt , will be

$$q_{CO_2} \cdot dt = \frac{c}{\frac{L}{D_L} + \frac{x_{CO_3}}{D_0}} \cdot dt \quad [\text{kg CO}_2/\text{m}^2] \quad [c]$$

This amount of carbon dioxide will move the carbonation front dx_{CO_3} , and the amount of carbon dioxide that reacted $a_0 \cdot dx_{CO_3}$, must be equal to the amount transported to the front

$$q_{CO_2} \cdot dt = \frac{c}{\frac{L}{D_L} + \frac{x_{CO_3}}{D_0}} \cdot dt = a_0 \cdot dx_{CO_3} \quad [\text{kg CO}_2/\text{m}^2] \quad [d]$$

An “equivalent thickness” L_{eq} of the repair material, with diffusion coefficient D_L , can be defined as a thickness of a concrete with diffusion properties equal to the original concrete having a diffusion resistance equal to the repair material

$$R_L = \frac{L}{D_L} = \frac{L_{eq}}{D_0} \quad [e]$$

Rearranged, acknowledging the moisture dependency of the diffusion coefficients, we get Equation [4]

$$L_{eq} = L \frac{\overline{D_0}(RH_2)}{D_L(RH_L)} \quad [4]$$

With D_L from equation [4] inserted into equation [d], we get

$$q_{CO_2} \cdot dt = \frac{c}{\frac{L \cdot L_{eq}}{D_0 \cdot L} + \frac{x_{CO_3}}{D_0}} \cdot dt = a_0 \cdot dx_{CO_3} \quad [\text{kg CO}_2/\text{m}^2] \quad [f]$$

we get

$$\frac{c \cdot D_0}{a_0} \cdot dt = (x_{CO_3} + L_{eq}) \cdot dx_{CO_3} \quad [g]$$

By integration, from $t=0$ to t_{d-x_1} and $x=x_1$ to d (the cover to the steel), and rearranging, we get Equation [3]

$$t_{d-x_1} = \frac{(d + L_{eq})^2 - (x_1 + L_{eq})^2}{2 \cdot \overline{D_0}(RH_2) \cdot c / a_0} \quad [3]$$

APPENDIX 3

ION REDISTRIBUTION AFTER CONCRETE REPAIR

CONTENTS	Page
1 BACKGROUND	86
2 OBJECTIVE	86
3 THE PROBLEM	86
3.1 Replacement of a part of the original concrete	87
3.2 Addition of a repair material at the surface of the original concrete	89
3.3 Surface treatment and surface cover	90
3.4 Example of measured redistribution	91
4 REQUIRED INPUT	92
5 THE PROBLEM FORMULATION	93
6 ChloreDistr – A SIMPLE TOOL	95
6.1 Assumptions & input data	95
6.2 Example 1: Part replacement	95
6.2 Example 2: Addition/shotcrete	95
6.3 Example 3: Replacement by shotcrete	100
6.5 Limitations	100
7 REFERENCES	101

1 Background

Repair of a concrete structure may aim at, or cause, redistribution of soluble substances in the original concrete. Typical examples are measures taken to change the chloride content in the vicinity of the reinforcement. Three typical cases can be identified:

3. Replacement of a part of the original concrete, causing “extraction” of ions from the remaining original concrete into the replacement.
4. Addition of a repair material at the surface of the original concrete, causing “extraction” of ions from the original concrete.
5. Surface treatment and surface cover, changing the conditions for further ingress.

These processes are complicated and rarely dealt with in scientific research, but frequently used as repair options without a quantitative design. This paper aims at presenting the content of the problem and required input for quantifying the effect of a repair method. A first, simple tool to use for evaluation is also presented, together with demand for future research to improve the tool.

2 Objective

The objective of an evaluation tool for redistribution of soluble substances after concrete repair is to be able to predict the changes in distribution of the substance caused by a repair. With such a tool it would be possible to quantitatively evaluate how much the service-life is prolonged because of a repair and to estimate the required extent of a repair to achieve a certain prolongation of the service-life.

The paper takes chloride as an important example but the same approach could be utilized for any other soluble substance, such as sulfates and alkalis.

3 The Problem

Before repair the original concrete has a certain content distribution of chloride. An example is shown in Figure 1.

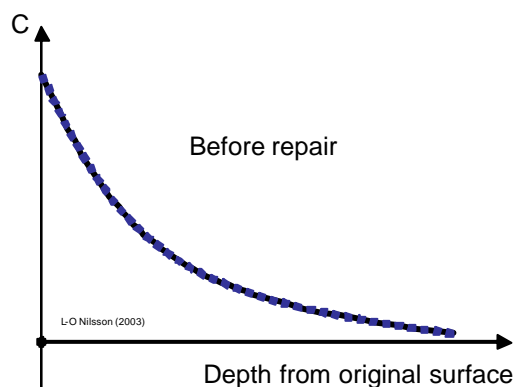

Fig. 1 The chloride profile before repair

The chloride profile is the response by the original concrete to environmental actions during service, up to the point of inspection. It follows from the type, duration and magnitude of the environmental actions and the properties of the concrete. In principal, a thorough inspection and measurements of chloride and moisture profiles can be utilized to determine, or at least

estimate, the chloride transport properties of the original concrete and the previous environmental actions.

A repair method involving part replacement of the old concrete, or adding a repair material or surface cover, will change the future chloride distribution. The three typical cases are presented in the next sections, original ideas from Fagerlund (1988).

3.1 Replacement of a part of the original concrete

A portion of the original concrete could be removed in a repair. A repair material could then replace a part, all or more than the removed concrete. Directly after the repair chloride will only be present in the remaining part of the original concrete, providing that the repair material has an insignificant chloride content, se Figure 2.

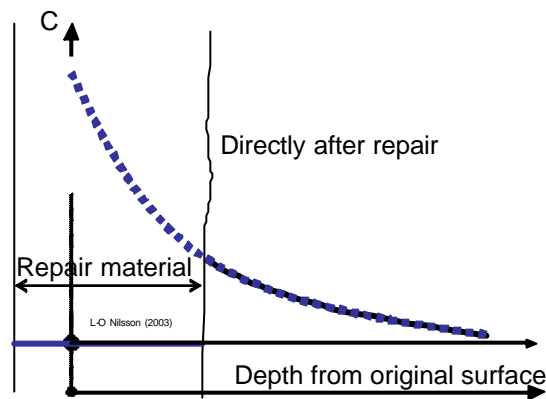

Fig. 2 The chloride profile directly after repair when a part of the original concrete has been partly or fully replaced by a repair material.

After the repair the remaining chloride in the remaining part of the original concrete will continue to penetrate further into the concrete, but part of it will be “extracted” by the repair material through the interface between the repair material and the concrete. Simultaneously, chloride will penetrate into the repair material through the outer surface.

The chloride profile through the repair material and the remaining part of the original concrete, at some time after repair, will look like the one in Figure 3.

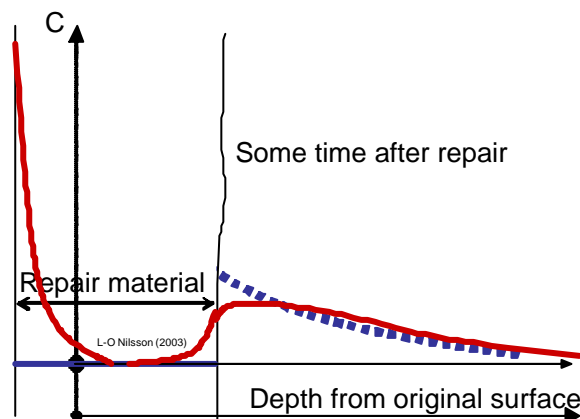

Fig. 3 The chloride redistribution at some time after repair, when a part of the original concrete has been partly or fully replaced by a repair material.

Depending on where the reinforcement is placed, the chloride content in the vicinity of the steel may decrease with time.

3.2 Addition of a repair material at the surface of the original concrete

An alternative repair could be to keep the original concrete, with its chloride content, but a repair material is added at the surface, see Figure 4.

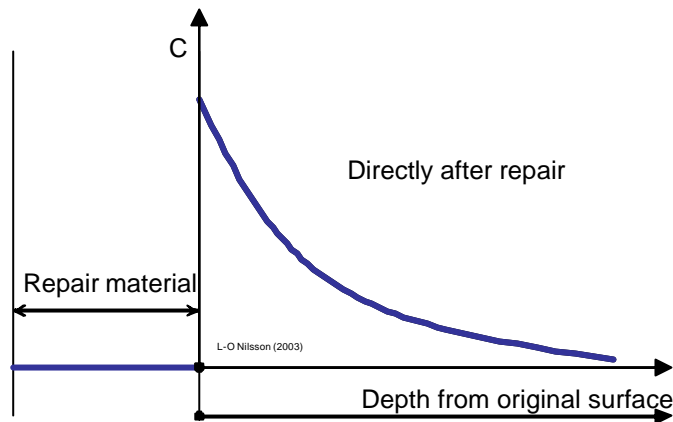

Fig. 4 The chloride profile directly after repair when a repair material has been added to the surface of the original concrete.

Then, after the repair the chloride in the original concrete will continue to penetrate further into the concrete, but part of it will be “extracted” by the repair material through the interface between the repair material and the concrete. Simultaneously, chloride will penetrate into the repair material through the outer surface.

The chloride profile through the repair material and the original concrete, at some time after repair, will look like the one in Figure 5.

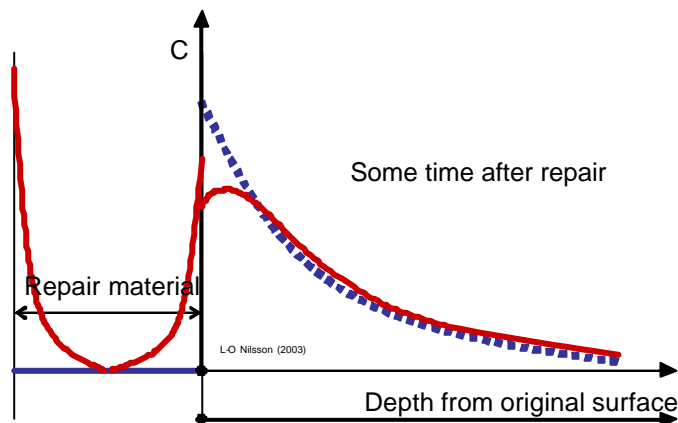

Fig. 5 The chloride redistribution at some time after repair, when a repair material has been added to the surface of the original concrete.

Depending on the position of the reinforcement in the original concrete, the chloride content around it may drop with time.

3.3 Surface treatment and surface cover

If the only repair is a surface cover or a surface treatment, depending on its properties, could change the chloride profile after the repair. The starting point would be like in Figure 6.

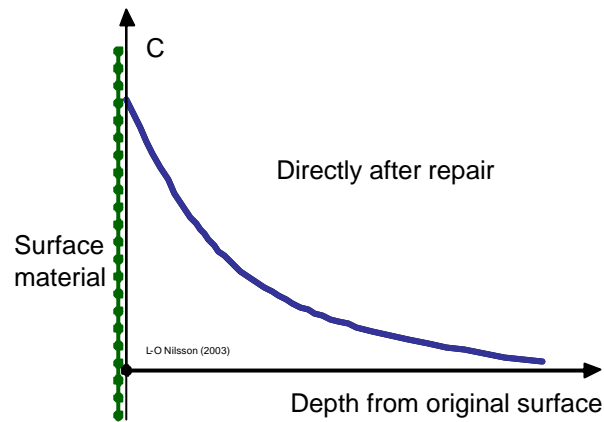

Fig. 6 The chloride profile directly after repair when a surface cover or treatment has been added to the surface of the original concrete.

Some time after the repair, if the surface protection adds some significant resistance to chloride ingress, the chloride content close to the surface of the original concrete should start to drop. Simultaneously, the chloride at larger depths will continue to penetrate inwards, cf. Figure 7.

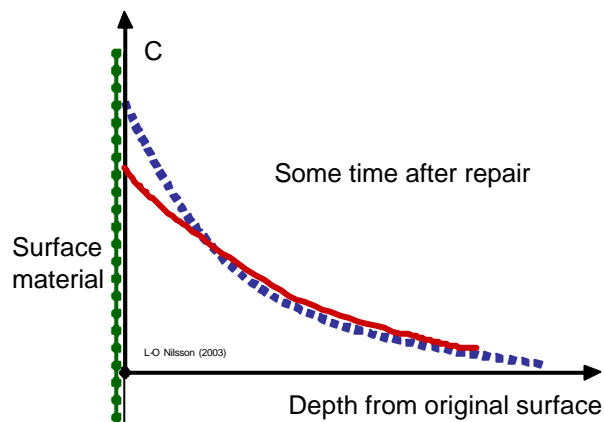

Fig. 7 The chloride redistribution at some time after repair, when a surface cover or treatment has been added to the surface of the original concrete.

Once again, depending on the position of the reinforcement the chloride content in the vicinity may drop with time.

3.4 Example of measured redistribution

In a recent investigation chloride profiles were determined in caissons in a harbour at the west coast of Sweden. At one of the caissons a 210 mm thick layer of concrete was cast around the caisson, in the splash zone, eight years ago. The profiles in two points in the new layer and one point in the old concrete is shown in Figure 8.

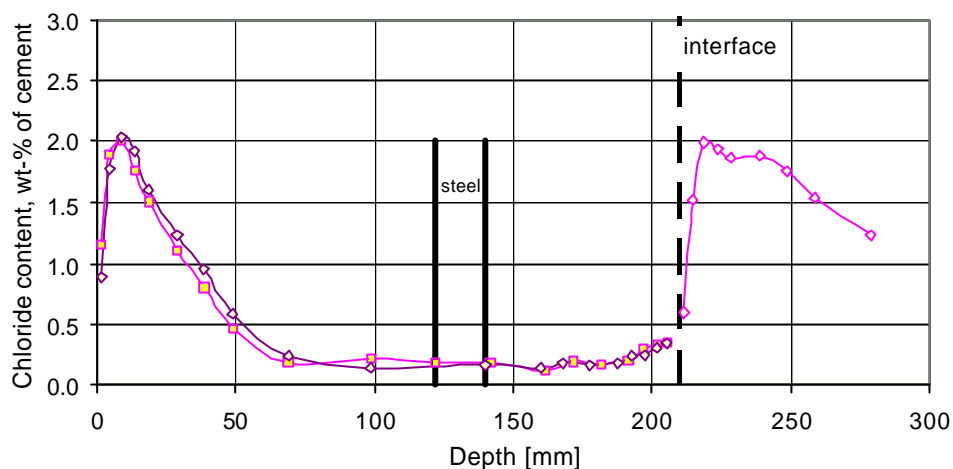

Fig. 8a The chloride redistribution 8 years after repair, when a new 210 mm layer of concrete has been added to the surface of the original, 38 year old concrete.

In these eight years chloride has penetrated more than 50 mm into the new layer. The reinforcement, however, is placed much deeper, at a depth of some 120-140 mm. From the figure it is clear that the chloride content of the new concrete has increased close to the interface. The “concrete addition” obviously extracted some chloride from the old concrete, also shown by the lower chloride content at the old surface compared to the new, outer surface. The figure also indicates that the C_s -values of the two concretes are approximately the same.

Another case is shown in Figure 8b, for a road bridge column exposed to de-icing salts and repaired with one 25 mm layer of shotcrete.

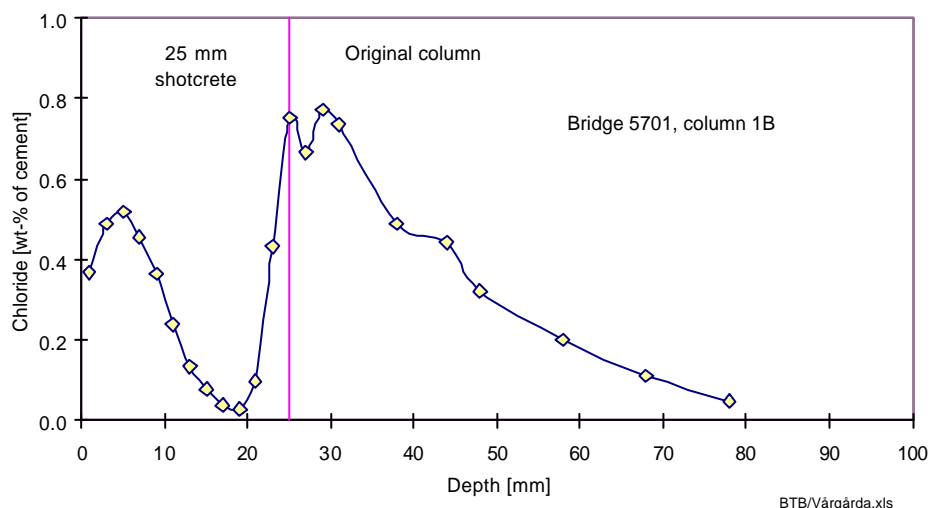

Fig. 8b The chloride redistribution after 25 mm layer of shotcrete has been added to the surface of the original road bridge column.

4 Required input

The relevant content of an evaluation tool for redistribution of chloride after repair depends on the available input data for the original concrete and the repair material. The more relevant information that is available, the better prediction could be made and, consequently, the more sophisticated evaluation tool could be utilized. A minimum required set of input data is

4. the distribution of substance in the original concrete,
5. the ion binding and transport properties of the repair material,
6. the ion binding and transport properties of the original concrete,
7. a measure of the previous and future environmental actions at the concrete surface

These input data could be enough for predicting the redistribution of substance after a repair of a concrete structure that has been, and will be, more or less saturated with pore water. A more correct prediction, for non-saturated concrete and repair material, requires some additional input data to predict the future moisture (and temperature) distribution after repair. This is presented in a separate document as an evaluation tool for moisture distributions after concrete repair, Janz (September 2003).

5 The Problem formulation

The three typical cases presented in section 3 can actually be condensed into one mathematical problem, see Figure 9, providing the effect of moisture and moisture changes is neglected. One concrete called 0 (zero) has an initial chloride content distribution $C_0(x_0, t_0)$ that has been derived from exposure during a certain time t_0 . The apparent chloride diffusion coefficient for concrete 0 is D_0 . The exposure has given a response in terms of a surface chloride content corresponding to C_{s0} .

Concrete 0 is combined with a repair material 1 at time t_0 , having a zero chloride content. The apparent diffusion coefficient for the repair material is D_1 and the thickness of the repair is L . The chloride binding properties of the repair material will give a surface chloride content of C_{s1} at the outer surface of the repair material from the same environmental actions as before.

Comparing the three typical cases in sections 3.1-3.3 with this mathematical formulation of the problem, the three cases are translated in these ways:

Case 1. Replacement

The remaining part of the original concrete is “concrete 0”, with the remaining chloride profile $C(x_0, t_0)$, and a repair material 1 with a thickness L . L does not necessarily have to be equal to the thickness of the removed part of the original concrete! The depth x_0 in the remaining part of the original concrete is calculated from the interface between the two materials.

Case 2. Addition

The original concrete is “concrete 0” with the depth x_0 calculated from the interface between the two materials, i.e. the original surface of the original concrete. The repair material 1 has a thickness of L .

Case 3. Surface cover or treatment

The original concrete is “concrete 0” with the depth x_0 calculated from the original surface of the original concrete. The repair material 1 has an “equivalent thickness” of L , derived from a special test method, e.g. Frederiksen (1994).

A solution to this problem also requires an interface condition, since two materials with different properties meet. The correct conditions should be that the concentrations of free chloride, $c_1(x_1=L)$ and $c_0(x_0=0)$ ¹, are equal. Consequently, the total chloride contents at the interface are not equal, if the porosity and chloride binding properties of the two materials differ.

A simple, analytical solution to this problem does not exist: $C(x_1, x_0, t)$ for different D_1, D_0, L and $C_0(x_0, t_0, D_0)$? Not even the simpler problem, with the interface condition changed to the total chloride contents being equal, cf. Figure 10, has a simple solution. Numerical solutions must be found!

¹ Definitions: C =total content of chloride (free+bound), c =content of free chloride in the pore water

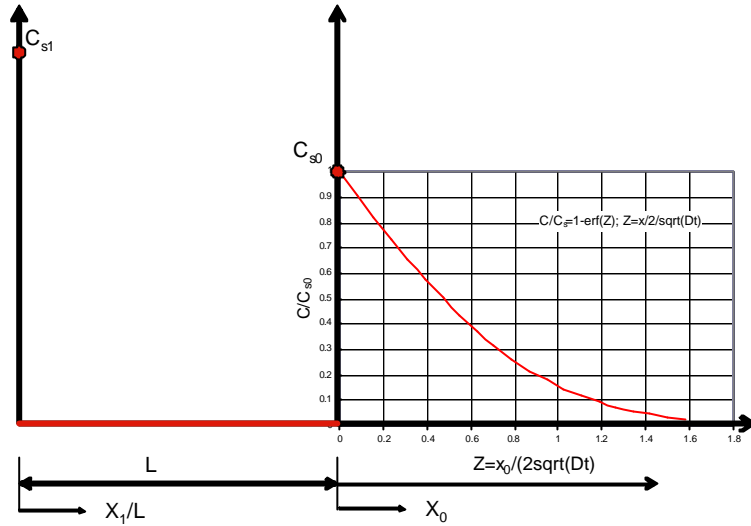

Fig. 9 A mathematical formulation of the initial and boundary conditions after a repair with any of the three typical cases in section 3.

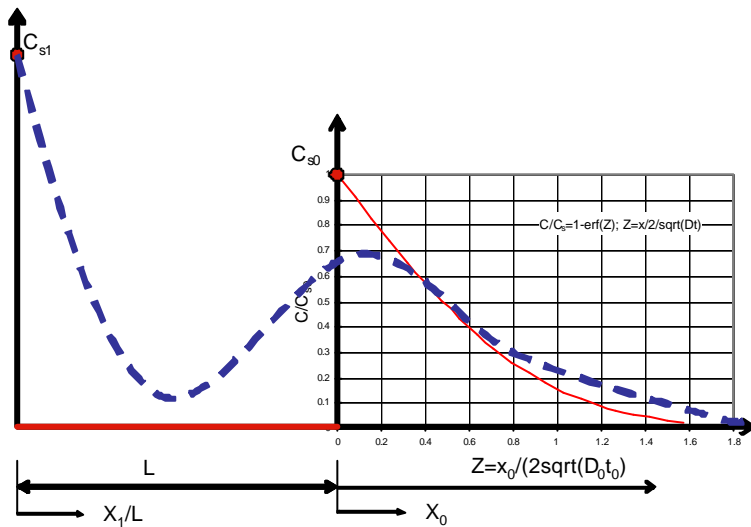

Fig. 10 A possible solution to the mathematical formulation in Figure 8, assuming the total chloride content being equal at the interface between concrete 0 and material 1.

6 ChloRedistr - A simple tool

For demonstration of the possibilities, the problem formulated in chapter 5 has been solved for a number of examples with a numerical tool. The basis for the model is a chloride ingress model, Nilsson (1997, 2000), that consider most parameters but only for one, homogeneous concrete. That model has been redesigned to include an outer layer of a material with different properties and the possibility to start with an initial chloride profile in the original concrete.

6.1 Assumptions & input data

In the model chloride transport is described with Fick's 1st law of diffusion, with the concentration of free chloride as the driving potential and with separate chloride binding isotherms for the two materials. Consequently, the interface condition between the two materials is correctly described and not as in Figure 10.

The relation between the chloride diffusion coefficient D_{F1} in Fick's 1st law and the apparent diffusion coefficient $D_a (=D_{F2})$ in Fick's 2nd law is given by, Nilsson et al (1996),

$$D_{F2} = \frac{D_{F1}}{p \cdot \frac{\partial C}{\partial c}} \quad [1]$$

where p is the available porosity for chloride and dC/dc is the chloride binding capacity.

6.2 Example 1: Part Replacement

In the first example a prediction was made of ten years of redistribution of chloride after a repair where 80 mm of the old concrete was removed and replaced by a new, better concrete. In the old concrete the remaining chloride corresponds to an "interface chloride content" of 0.8 wt-% of cement. The apparent chloride diffusion coefficients were chosen to $D_{a1} = 0.5 \cdot 10^{-12} \text{ m}^2/\text{s}$ for the new concrete and $4 \cdot 10^{-12} \text{ m}^2/\text{s}$ for the old one. The redistribution during the first ten years after repair is shown in Figure 11.

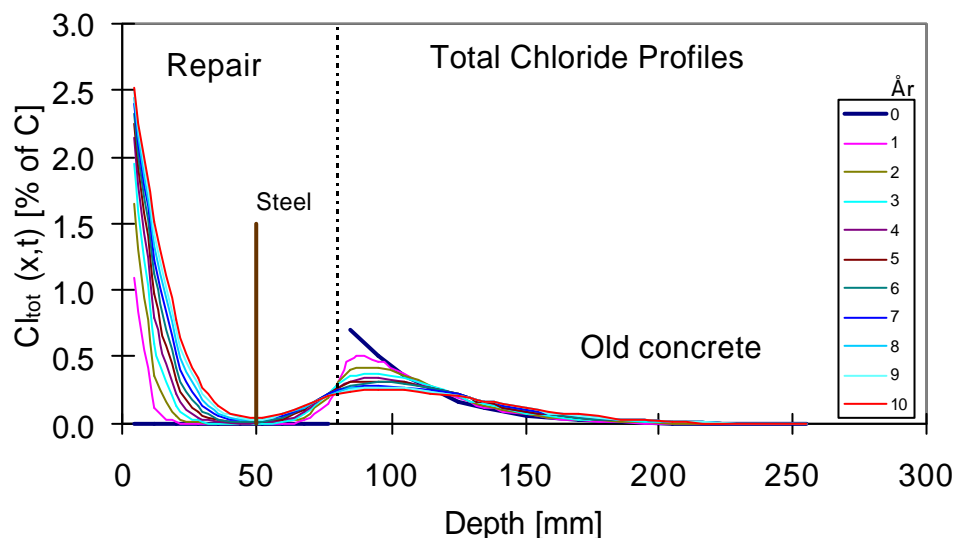

Fig. 11 10 years redistribution of chlorides after repair where 80 mm chloride contaminated concrete was replaced by a new, better concrete. Chloride remaining in the old concrete corresponds to 0.8 wt-% of cement at the interface. $D_{a1} = 0.5 \cdot 10^{-12} \text{ m}^2/\text{s}$ for the new concrete, $4 \cdot 10^{-12} \text{ m}^2/\text{s}$ for the old one

If the steel still is placed at a depth of 50 mm in the material combination, the remaining chloride will not at all reach the steel during these ten years! The chloride content depends more on the resistance to chloride ingress of the new concrete.

The continuation is shown in Figure 12, as redistribution during 60 years.

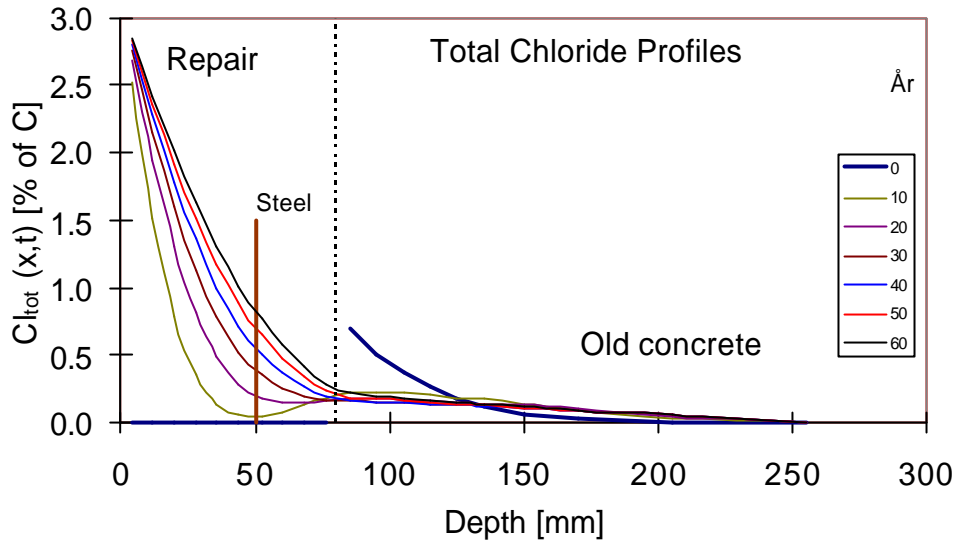

Fig. 12 60 years redistribution of chlorides after repair where 80 mm chloride contaminated concrete was replaced by a new, better concrete. Chloride remaining in the old concrete corresponds to 0.8 wt-% of cement at the interface. $D_{a1} = 0.5 \cdot 10^{-12} \text{ m}^2/\text{s}$ for the new concrete, $4 \cdot 10^{-12} \text{ m}^2/\text{s}$ for the old one

From this prediction it is seen that 50 mm cover is a little too small if the chloride threshold level for corrosion is 0.5 wt-% of cement. During some 30 years, however, the chloride level is lower than such a threshold.

6.3 Example 2: Addition/shotcrete

A few predictions were made for a case where the old concrete remains, with its chloride content, but a layer of 50 mm shotcrete is added. A somewhat larger chloride diffusion coefficient for the repair material is chosen, $D_{a1} = 1 \cdot 10^{-12} \text{ m}^2/\text{s}$.

If the original concrete had remaining chlorides corresponding to 0.8 wt-% of cement at a depth of 50 mm, the prediction gives the result in Figure 13.

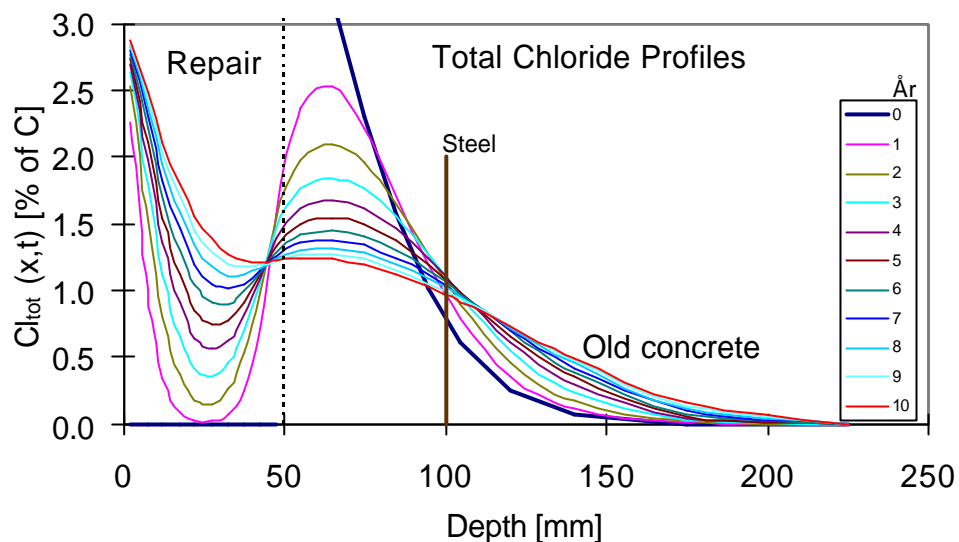

Fig. 13 10 years redistribution of chlorides after repair where 50 mm shotcrete was applied at an old concrete with chlorides remaining in the old concrete corresponding to 0.8 wt-% of cement at a depth of 50 mm. $D_{a1} = 1 \cdot 10^{-12} \text{ m}^2/\text{s}$ for the new concrete, $4 \cdot 10^{-12} \text{ m}^2/\text{s}$ for the old one

The steel is now at a depth of 100 mm in the figure. At that depth the chloride content does not decrease at all, but increases during the ten years of redistribution!

The same prediction, but now with only half the amount of remaining chloride content, 0.4 % at the steel, gives the result in Figure 14.

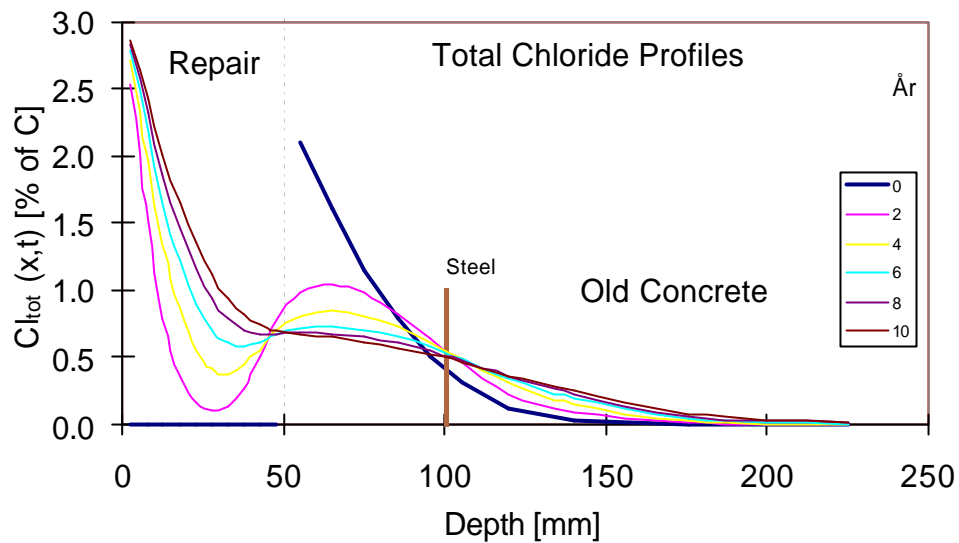

Fig. 14 10 years redistribution of chlorides after repair where 50 mm shotcrete was applied at an old concrete with chlorides remaining in the old concrete corresponding to 0.4 wt-% of cement at a depth of 50 mm. $D_{cl} = 1 \cdot 10^{-12} \text{ m}^2/\text{s}$ for the new concrete, $4 \cdot 10^{-12} \text{ m}^2/\text{s}$ for the old one

Not even now will the chloride content decrease at depth of 50 mm in the original concrete! However, it does not significantly increase above a possible threshold of 0.5 % during 10 years of redistribution. The repair method had been better if the remaining cover was thinner than the thickness of the applied layer. A thicker layer of shotcrete could have the same effect: the steel would face a decreasing chloride content!

Another 50 years redistribution will give the results in Figure 15.

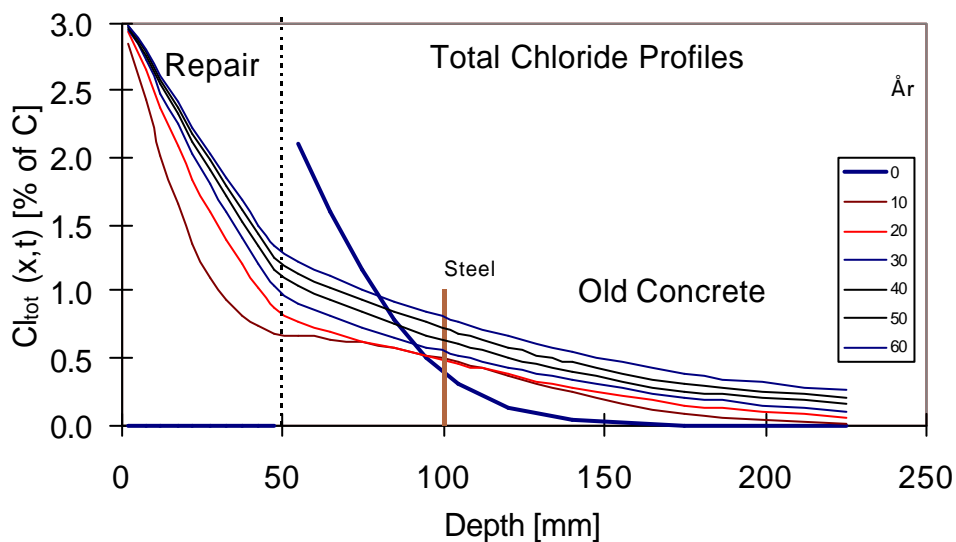

Fig. 15 60 years redistribution of chlorides after repair where 50 mm shotcrete was applied at an old concrete with chlorides remaining in the old concrete corresponding to 0.4 wt-% of cement at a depth of 50 mm. $D_{cl} = 1 \cdot 10^{-12} \text{ m}^2/\text{s}$ for the new concrete, $4 \cdot 10^{-12} \text{ m}^2/\text{s}$ for the old one

The repair concrete has such a large resistance to chloride ingress that the penetration of chloride through the repair material will be so limited that the chloride content in the old concrete will remain low during 60 years!

With only one layer of shotcrete, 25 mm, the redistribution will be, as shown in Figure 16, very limited.

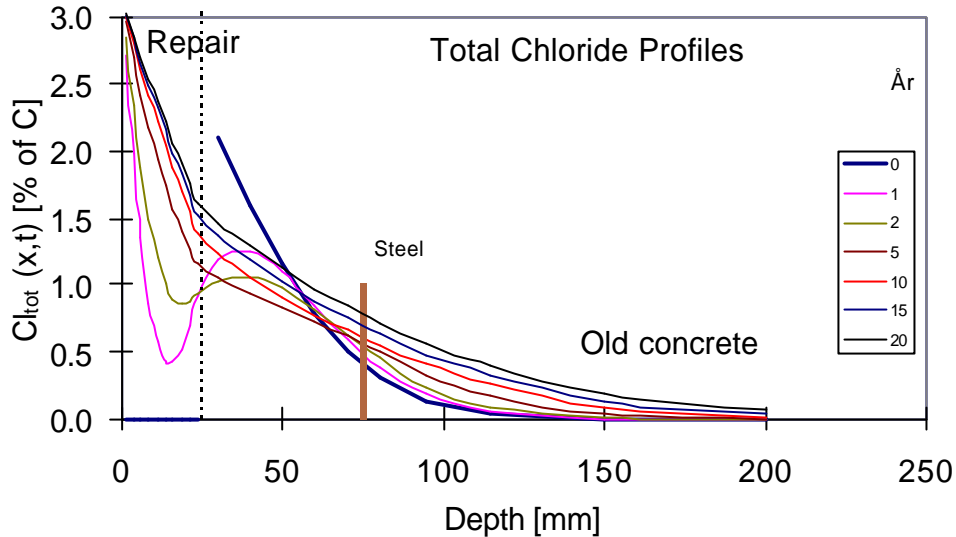

Fig. 16 20 years redistribution of chlorides after repair where 25 mm shotcrete was applied at an old concrete with chlorides remaining in the old concrete corresponding to 0.4 wt-% of cement at a depth of 50 mm. $D_{a1} = 1 \cdot 10^{-12} \text{ m}^2/\text{s}$ for the new concrete, $4 \cdot 10^{-12} \text{ m}^2/\text{s}$ for the old one

The shotcrete, however, has such a large resistance that the rate of continuous chloride ingress will be very low. After some 20 years the chloride content only increased from 0.4 to some 0.8 %.

6.4 Example 3: Replacement by shotcrete

Removal of 50 mm cover and replacing that with two layers of shotcrete, with 0.8 % chloride remaining at the steel, gives the prediction in Figure 17.

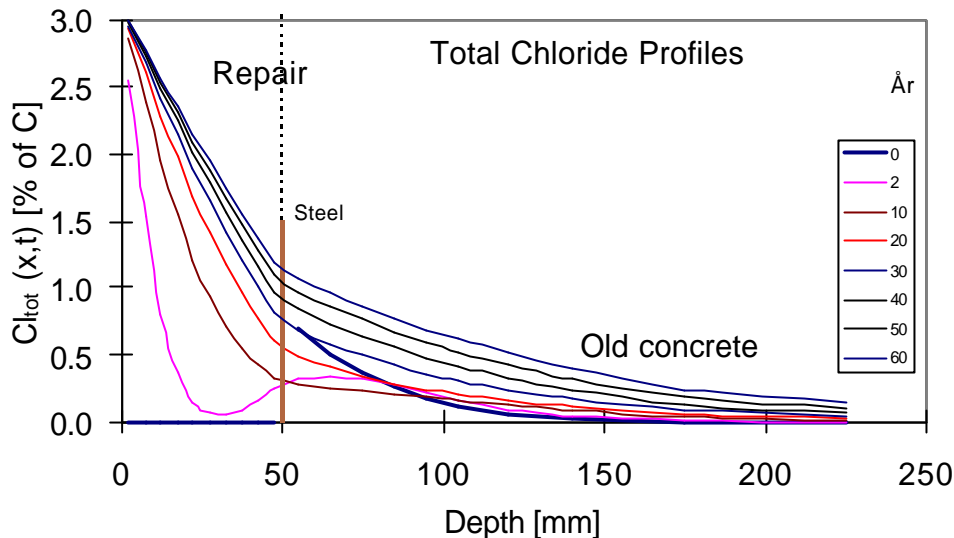

Fig. 17 60 years redistribution of chlorides after repair where 50 mm shotcrete replaced the 50 mm cover in the old concrete with chlorides remaining in the old concrete corresponding to 0.8 wt-% of cement at a depth of 50 mm, corresponding to the cover thickness. $D_{cl} = 1 \cdot 10^{-12} \text{ m}^2/\text{s}$ for the new concrete, $4 \cdot 10^{-12} \text{ m}^2/\text{s}$ for the old one

The chloride content now decreases rapidly close to the steel, to below 0.3-0.4 %. The chloride content at the steel then increases very slowly. Not until after some 30-40 years the chloride content is back at 0.8 %.

6.5 Limitations

The type of predictions like the ones shown in chapter 5 should not be regarded as too accurate! Prediction of chloride ingress still is not an “exact science”, with true, absolute numbers for penetration depths and chloride levels after a certain time. The numbers should be good estimates, however. There is even a possibility that the predictions are too much on the safe side, since one important parameter was not included: the time-dependent decrease of the apparent diffusion coefficient D_a . Good data from long term exposure is simply missing to update the models!

7 References

- /1/ Fagerlund, G (1988). *The service-life of the repaired structure* (in Swedish), section 2.4 of *The Concrete Hand Book. Repair*. Svensk Byggtjänst , Stockholm 1988.
- /2/ Janz, M (2003) *Moisture balance at the interface between repair material and concrete*. Draft 1, September 2003, CBI, Stockholm
- /3/ Frederiksen, J. M. (1994) *APM 042 – Concrete testing, concrete repair: Chloride penetration resistance of paint on concrete*, 1st edition, January 1994.
- /4/ Nilsson, L.-O., Poulsen, E., Sandberg, P., Sørensen, H.E. & Klinghoffer, O. (1996) *Chloride penetration into concrete. State of the Art*. HETEK. Danish Road Directorate Report No 53 1996.
- /5/ Nilsson, L-O (1997) *A Model for Convection of Chloride*, Chapter 7 from Nilsson, L-O, Sandberg, P, Poulsen, E, Tang, L, Andersen, A. (1997) *A System for Estimation of Chloride Ingress into Concrete. Theoretical Background*. HETEK Report 83, Danish Road Directorate, Copenhagen.
- /6/ Nilsson, L-O (2000) *A numerical model for combined diffusion and convection of chloride in non-saturated concrete*. Proceedings from 2nd International Workshop on *Testing and Modelling the Chloride Ingress into Concrete*, 11-12 September 2000, Paris (editor: C Andrade).

APPENDIX 4

EXAMPLE OF QUANTITATIVE SERVICE LIFE EVALUATION

Contents	Page
GENERAL COMMENTS TO THE EXAMPLE	103
BACKGROUND INFORMATION TO THE EXAMPLE	104
OPERATIONAL REQUIREMENT 1 Service life with regard to reinforcement corrosion	106
OPERATIONAL REQUIREMENT 2 Service life with regard to combined salt-frost and reinforcement corrosion	116
OPERATIONAL REQUIREMENT 3 Service life with regard to combined chemical attack and reinforcement corrosion	120
OPERATIONAL REQUIREMENT 4 Evaluation of the service life of the new cover	122
OPERATIONAL REQUIREMENT 5 Evaluation of the frost resistance of the old (sub-base) concrete	124
OPERATIONAL REQUIREMENT 6 Evaluation of the durability of bond	125
REFERENCES	126

GENERAL COMMENTS TO THE EXAMPLE

In this report an example is given of how a quantitative service life evaluation of a repair system might be performed. It is quite clear that the evaluation performed will not give a precise answer of service life expressed in years. The input data for repair material and sub-base concrete are simply too uncertain, even if they are determined by good test methods. Nevertheless, an evaluation of this type will give a much better picture of the service life to be expected than just selecting a repair without any attempt to quantify its long-term function.

The example selected, protection against reinforcement corrosion, is one of the most easy to handle in a service life assessment, since fairly good destruction models exist. As shown by the example, even this straightforward case is complex, if also synergetic effects and different mechanical interaction between repair and sub-base concrete should be considered -which they ought to be.

The evaluation relies upon good test methods, including also durability tests of the interaction between the sub-base concrete and the repair material. Almost no standardised such test methods exist today. Methods ought to be developed.

BACKGROUND INFORMATION TO THE EXAMPLE

Damage cause:

Chloride induced reinforcement corrosion

Damage type:

Spalling of cover

Type of structure:

Alt 1: Bridge pier in seawater

Alt 2: Edge beam of bridge exposed to de-icing salt.

Climate:

Alt 1: seawater splash. No frost

Alt 2: de-icing salt. Frost

Repair method:

- Removing chloride infected concrete to a safe remaining chloride level (a residual chloride content <0,1% of cement weight.)
- Adding new reinforcement as replacement for corroded.
- Casting new cement-based concrete cover in mould (alternative: polymer-modified cement-based concrete, or shotcrete).
- Bonding new concrete cover to old concrete by cement paste slurry or polymer-based bonding agent.
- Water curing new concrete cover.

Owners basic requirement of the repaired structure:

Full function (prescribed load-carrying capacity/safety and prescribed serviceability) shall be maintained for at least 40 years after repair.

Operational requirements constituting the basic requirement:

In order to be able to evaluate repair with regard to the Owners basic requirement this has to be divided into a number of secondary operational requirements that are possible to handle. For the actual repair these operational requirements are:

1: The repair concrete must limit the diffusion of chloride ions into the cover to a value that does not make the chloride concentration at the surface of the reinforcement (main and secondary) reach the initiation concentration until 40 years after repair was made.

2: Future salt-frost scaling of the repair concrete may not be so deep that the requirement for service life with regard to corrosion of reinforcement cannot be met.

3: Future seawater attack, and leaching attack, on the new cover may not be so deep that the requirement for service life with regard to corrosion of reinforcement in the old concrete cannot be met.

4: The concrete used for repair must be resistant to internal frost damage and chemical attack from sea water or de-icing salts. This means that frost or chemical attack must not negatively affect strength and transport properties for gases and chloride ions to such a degree that structural stability and service life with regard to corrosion of reinforcement cannot be met.

5: The repair material must protect the old structural concrete from being critically saturated with regard to internal frost damage during the entire required service life.

6: Differential thermal and moisture movements between sub-base concrete and repair concrete, and other destructive forces, must not lead to loss of bond.

All these secondary operational requirements are treated below.

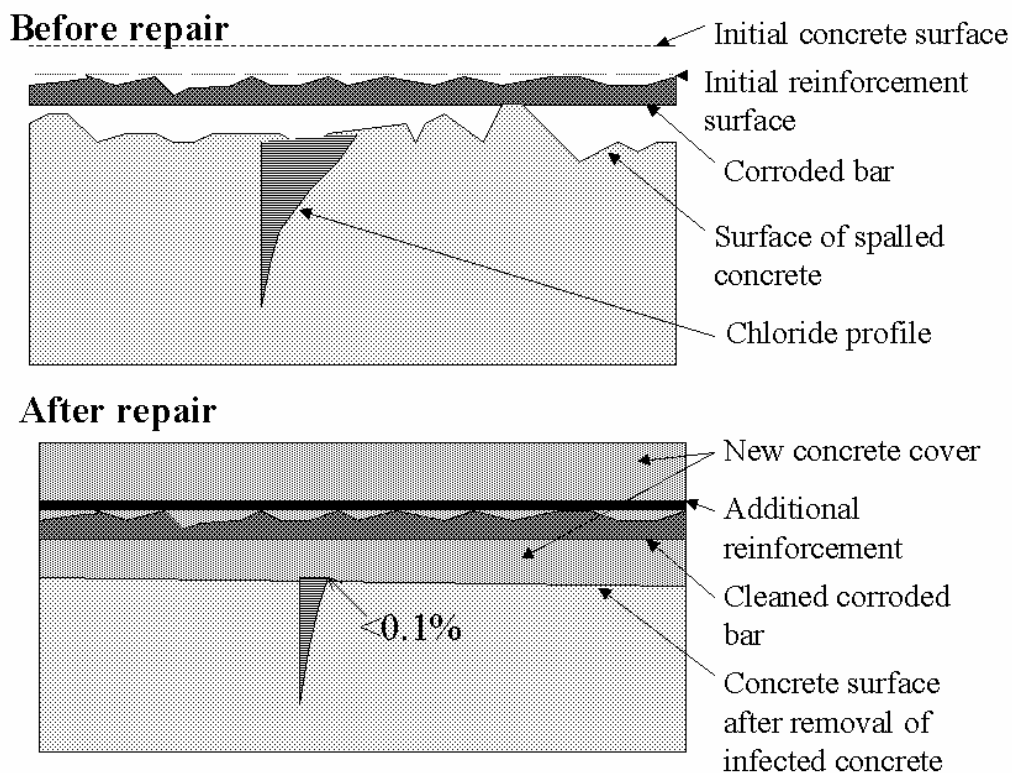

Figure 1: The example

OPERATIONAL REQUIREMENT 1: SERVICE LIFE WITH REGARD TO REINFORCEMENT CORROSION

1 General considerations

1.1 Moisture conditions

The moisture level in the cover plays a fundamental role for service life with regard to reinforcement corrosion.

- Moisture determines the diffusion rate of chloride ions. The higher the moisture level, the higher the diffusion rate. At RH below about 80% diffusion is very much reduced due to lack of moisture in the pore system.
- Probably the threshold value for onset of corrosion is to a certain extent depending on the moisture condition at the steel surface.
- When the cover is completely saturated the corrosion rate is low due to lack of oxygen.

In the actual case corrosion will not be accepted. Therefore, the third effect of moisture described above is not relevant.

The structure is exposed to marine environment (or de-icing salt). This means that the moisture level in the cover is high enough to make corrosion possible. The most severe condition is when the moisture level is as high as possible. Therefore, in the evaluation of service life made below it is assumed that the concrete cover is “saturated” (RH=100%).

1.2 Evaluation principles

The penetration of chloride through the new cover is estimated on basis of the following information; (i) the chloride permeability of the cover considering chemical and physical binding of chloride, (ii) the surface concentration of chloride ions (the “driving concentration”).

The estimated chloride concentration at the reinforcement bars after the required service life is reached is compared with the threshold concentration needed for onset of corrosion.

This means that tests (or quantitative estimations) of the following properties must be made for the repair concrete; (i) diffusivity of chloride, (ii) chloride binding, (iii) threshold concentration, (iv) surface chloride concentration.

The following relation between service life and maximum allowed chloride diffusivity of the cover can be used assuming chloride penetration being a pure diffusion process with *time-independent chloride diffusivity and linear chloride binding* -Equation (3)- which is the solution to Fick’s law, neglecting the influence of other ions than Cl in the pore solution:

$$Cl_{thr}/Cl_s = \operatorname{erfc}\{T/(4\delta_{Cl}t_{req})^{1/2}\} \quad (1)$$

Where:

Cl_{thr} threshold concentration of chloride [weight-% of concrete or cement, or mole/litre]

Cl_s concentration of chloride at the surface [same units as for Cl_{thr}]

T thickness of new concrete cover (distance from surface to nearest bar) [m]

δ_{Cl} the effective chloride diffusivity of chloride [m^2/s] (diffusivity considering the "slowing-down" effect of chloride binding; assumed to be linear)

t_{req} the required service life (time to start of corrosion) [s]

This equation can be used for selecting a repair material with a threshold concentration high enough, and/or a chloride diffusivity low enough to secure a service life of at least t_{req} .

The equation gives a lower bound value of service life, since in reality chloride diffusivity is reduced with time and chloride binding is non-linear, Equation (4). Both factors contribute to an increase in service life compared to the solution given by Equation (1).

Note:

Chloride concentration should preferably be defined as free chloride; i.e. chloride ions in pore solution. Normally, however, total chloride content is used, i.e. the sum of free and chemically and physically bound (immobilized) chloride ions.

$$Cl_{tot} = Cl_{bound} + Cl_{free} \quad (2)$$

The reason why total chloride is used is that it is easier to determine experimentally than the free chloride, especially for concrete with low water-cement ratio.

In the simplest case -to which Equation (1) is applicable- there is a linear relation between bound and free chloride:

$$Cl_{bound} = K \cdot Cl_{free} \quad (3)$$

Normally, however, the relation (the binding isotherm) is non-linear. A commonly used relation is:

$$Cl_{bound} = K \cdot Cl_{free}^a \quad (4)$$

Where the exponent $a < 1$. Thus, proportionally more chloride is bound at low concentrations. A method for determining the binding isotherm is described in 3.3 below.

Equation (1) cannot be used for non-linear binding. In this case, Fick's law for diffusion must be solved numerically (Fick's law: $dc/dt = \delta \cdot (d^2c/dx^2)$, where c is the concentration of the moving substance, δ is the transport coefficient of this, x is the space coordinate, and t is time.)

The procedure and test methods for evaluating the effect on service life of the repair material will depend on whether free or total chloride is used. Both techniques are described below. In both cases it is assumed that chloride binding is linear.

2 Evaluation of service life based on free chloride concentration

2.1 Evaluation formula

Service life before onset of corrosion might be calculated by a modified Equation (1), assuming chloride binding being linear, and diffusion coefficient being time-independent:

$$\frac{[Cl_{thr}]}{[Cl_s]} = \operatorname{erfc}\left\{\frac{T}{(4d_{Cl} \cdot t_{req})^{1/2}}\right\} \quad (5)$$

Where:

$[Cl_{thr}]$ threshold concentration of *free* chloride [mole/litre]

$[Cl_s]$ concentration of *free* chloride at the surface [mole/litre]

T thickness of new concrete cover (distance from surface to nearest bar) [m]

δ_{Cl} the effective chloride diffusivity of free chloride [m^2/s]

t_{req} required service life (time to start of corrosion) [s]

2.2 Diffusivity of chloride ions

δ_{Cl} , the effective diffusivity of free chloride of the repair material, can be determined by a test method in which the material is immersed in a chloride solution with known concentration. The solution can either be representative for the actual environment, or be more concentrated (accelerated test). After a certain exposure time the chloride profile is determined. There are two possibilities:

- 1: The profile of *free* chloride. This is determined by crushing pieces taken from the concrete, from different depths from the surface, and determining the chloride content of pore water seeping out of the crushed material. Alternatively, it is determined from measurements of the profile of *total* chloride, making use of a known relation between free and total chloride (the chloride sorption isotherm); see Equations (2), (3), (4). The sorption isotherm can be determined experimentally; see paragraph 3.3 below
- 2: The profile of *total* chloride (free+bound). This is determined by titration of dissolved concrete pieces taken from different depths from the surface. The total chloride content can also be determined by chloride sensitive electrode.

The profile is used for calculating the effective diffusivity. This is done by applying Equation (5) (for the free chloride profile), or Equation (1) (for the total chloride profile) to the measured profiles. Both methods should theoretically give the same effective diffusivity provided chloride binding is linear, Equation (3). When total chloride is used it might be necessary to use an extrapolated, fictitious (non-physical) value for the surface concentration, see Figure 3. Principles for evaluation of δ_{Cl} are described in 2.5 and 3.5 below.

Note:

A diffusion test made on the virgin concrete will often give a diffusivity that is much higher than that valid for the long-term exposed concrete in its real environment, (1). Therefore, the diffusivity determined by the suggested test will be "on the safe side".

2.3 Threshold concentration of free chloride

A safe (lower-bound) value of $[Cl_{thr}]$ might be calculated by:

$$[Cl_{thr}] = 0,6 \cdot [OH] \quad (6)$$

Where:

$[OH]$ is the concentration of OH-ions in the pore solution close to the bars [mole/litre]

$$[OH] = 10^{pH-14} \quad (7)$$

Where pH is the PH-value of pore solution in contact with the reinforcement bar.

The pH-value can be measured on water drops squeezed out of the saturated virgin (un-carbonated) concrete used for repair (preferably this shall be pe-leached in pure water to a level corresponding to what occurs in practice on the depth of the reinforcement).

$[OH]$ can also be calculated on basis of information of the water-soluble alkali hydroxides in concrete close to the reinforcement bars (considering possible leaching of hydroxides during the service life). For portland cement based material, the following equation might be used:

$$[OH] = 0.32 \cdot x / (w/c - 0.15) \quad (8)$$

Where:

x the amount of alkali hydroxide expressed in terms of $(Na_2O)_{equiv}$ [weight-% of cement] ($(Na_2O)_{equiv} = Na_2O + 0.66 \cdot K_2O$)

w/c water/cement ratio

0.15 a constant based on the assumption of portland cement and 80% hydration.

Note:

When calculating $[OH]$ consideration ought to be taken to leaching of OH-ions. This will reduce the initial value of the cement alkalinity, x in Equation (8). $[OH]$ cannot be lower than the value corresponding to saturated $CaOH_2$ -solution; i.e. about 0.04 mole/litre.

2.4 Surface concentration

The surface concentration is often the most uncertain parameter in estimating service life. For completely immersed concrete, the surface concentration of *free* chloride ions $[Cl_s]$, driving chloride ions inwards, is equal to the chloride concentration of the outer solution surrounding the concrete. For other boundary conditions, the surface concentration of free chloride ions in the surface pores is often uncertain. Besides, the chloride load on the surface varies with time. It depends on the location above sea water level, splash of seawater, amount of de-icing salt, splash of de-icing salt solution, washing by rain, etc.

It seems reasonable to assume that the measured surface concentrations for relevant parts of the structure to be repaired, or for other similar structures in similar environment, can be used as an estimate for the surface concentration of the actual structure. A value to be used in the evaluation can for example be determined on pieces taken from unharmed parts of the same structure having been exposed to the same conditions. The same method as is used for determination of free chloride profile and diffusion coefficient can be used; see 2.2 above.

2.5 Effect of cracks in the cover

If the cover cracks, chloride will enter the cracks and reach the bar quite early. Therefore, it is essential that the new cover does not crack, or that no cracks open to the surface are formed at the interface between new cover and old concrete.

Lab tests and exposure tests in nature indicate that cracks will have marginal effects on corrosion resistance provided their width is below ~0.2 mm. The exact relation between crack width and corrosion properties of reinforcement is unknown.

It is important that shrinkage and other climate-induced movements are limited so that the cover can stay crack-free. An alternative solution is to add stainless steel fibres to the cover concrete.

Example 1

The required service life of the repaired structure is 40 years ($1.26 \cdot 10^9$ s.)

The structure is placed in the splash zone of seawater with a Cl⁻ concentration of 0.45 mole/litre. Due to splash, the free chloride concentration at the concrete surface is twice as high, 0.9 mole/litre. (The surface concentration can also be determined by sampling of concrete from the surface of the old concrete.)

As repair material concrete with w/c=0.5 is selected. The cement is of type low alkali Portland and has an equivalent Na₂O content of 0.6 weight-%. No pozzolanic materials are used.

Chloride diffusivity

A chloride diffusivity test of the concrete used for repair is performed in 1% NaCl-solution (1.7 mole/litre). After 3 months ($7.8 \cdot 10^6$ s) the following concentration of free chloride in the pore water is measured by pore-pressing:

10 mm from the surface: 0.36 mole/litre
 20 mm from the surface: 0.04 mole/litre

The diffusivity is obtained by using these values in Equation (5):

$$10 \text{ mm: } 0.36/1.7 = 0.21 = \operatorname{erfc}\{0.01/(4 \cdot \delta_{\text{Cl}} \cdot 7.8 \cdot 10^6)^{1/2}\}$$

A table over the error function gives $\delta_{\text{Cl}} = 4.6 \cdot 10^{-12} \text{ m}^2/\text{s}$

$$20 \text{ mm: } 0.04/1.7 = 0.024 = \operatorname{erfc}\{0.02/(4 \cdot \delta_{\text{Cl}} \cdot 7.8 \cdot 10^6)^{1/2}\}$$

This gives $\delta_{\text{Cl}} = 5 \cdot 10^{-12} \text{ m}^2/\text{s}$; i.e. about the same value as for 10 mm depth.

Note

In reality, there are many more experimental values than two. Thus, by comparing all these results with the theoretical chloride profile as given by Equation (5) more safe values of Cs and Cl can be obtained. Also, the possible existence of non-linear binding isotherms might be revealed this way.

Threshold value

The OH-concentration is given by Equation (8):

$$[\text{OH}] = 0.32 \cdot 0.5 / (0.5 - 0.15) = 0.46 \text{ mole/litre}$$

The threshold value is according to Equation (6)

$$[\text{Cl}_{\text{thr}}] = 0.6 \cdot 0.46 = 0.28 \text{ mole/litre}$$

Required thickness of repair material, T

This can be calculated by Equation (5):

$$0.28 / 0.9 = 0.311 = \text{erfc} \left\{ T / (4 \cdot 5 \cdot 10^{-12} \cdot 1.26 \cdot 10^9)^{1/2} \right\}$$

The required thickness of repair is **11.4 cm**.

Alternative repair

The thickness of the repair can be reduced by two alternatives:

1. Use of cement with higher alkalinity. This will increase the threshold value
2. Use of lower w/c-ratio. This will reduce the threshold value and reduce chloride diffusivity.

The alternative of using another cement is tested. Diffusivity is supposed to be unchanged (a dubious assumption since the effective diffusivity depends to some extent on the chemical composition of the cement. Thus, a new test of diffusivity should be made.)

$$\text{Na}_2\text{O} = 1.1\%$$

$$[\text{OH}] = 0.32 \cdot 1.1 / (0.5 - 0.15) = 1.01 \text{ mole/litre}$$

$$[\text{Cl}_{\text{thr}}] = 0.6 \cdot 1.01 = 0.60 \text{ mole/litre}$$

$$0.60 / 0.9 = 0.667 = \text{erfc} \left\{ T / (4 \cdot 5 \cdot 10^{-12} \cdot 1.26 \cdot 10^9)^{1/2} \right\}$$

The required thickness of repair is **4.9 cm**.

3 Evaluation of service life based on total chloride concentration

3.1 Evaluation formula

Service life before onset of corrosion might be calculated by Equation (1), assuming chloride binding being linear and diffusion coefficient being time-independent:

$$Cl_{thr}/Cl_s = \text{erfc}\{T/(4 \cdot d \cdot Cl_{req})^{1/2}\} \quad (1)$$

Where Cl_{thr} and Cl_s are *total* content of chloride ions. Chloride content is often expressed as weight-% of concrete, or weight-% of cement.

3.2 Diffusivity

δ_{Cl} , the effective diffusivity of *total* chloride of the repair material can be determined by a test method in which the material is immersed in a chloride solution with known concentration. After a certain exposure time the profile of total amount of chloride (bound+free) is determined. The method is described in 2.2 above (“possibility 2”). On basis of this profile an effective diffusivity is calculated by Equation (1) using an extrapolated value of the surface concentration.

Note:

Ageing effects occurring in practice might reduce the measured value; see paragraph 2.2. This effect makes the measured value to be on “the safe side”.

3.3 Threshold concentration

The threshold concentration of *total* chloride must be known if the service life calculation should be reliable. The threshold value depends on the type of cement and is probably also a function of the water-binder ratio. There is no existing safe experimental technique for determining the threshold value of total chloride.

Two simplified methods are suggested:

Method 1:

This is based on the theoretical threshold concentration of free chloride -Equation (6)- combined with Equation (2), and the binding isotherm, Equation (4):

$$Cl_{thr,tot} = K \cdot (Cl_{thr,free})^a + Cl_{thr,free} \quad (9)$$

Where $Cl_{thr,free}$ is the threshold concentration of free chloride based on Equation (6), and re-calculated to the same unit as is used for total chloride; i.e. weight-% of concrete or cement.

The binding isotherm can be determined by immersing thin specimens in a chloride solution with known concentration. After the specimens have reached equilibrium with the solution, the total chloride content in the specimens is determined. The difference between this value and the amount of free chloride in the pores (pore water concentration is assumed to be equal to the outer concentration) gives the amount of bound chloride.

Method 2:

This is based on "reasonable values", i.e. values based on field investigations, which, however, are normally of low significance. The values in Table 1 have been suggested in Sweden. As seen, the variation in chloride threshold is very big. For safety reasons one can use the lowest values.

Table 1: Threshold concentration of total chloride (acid soluble chloride) expressed as weight-% of cement (2).

Environment	Type of binder			
	Portland cement	8% silica fume	15% fly ash	15% slag
Cyclic moisture and drying	0.7 (var. 0.6-2.2)	0.4 (0.3-1.5)	0.5	0.5
Constantly high moisture level	1.5 (var. 1.5-2.2)	0.8 (0.8-1.9)	1.0 (0.9-1.4)	1.0 (0.8-2.0)
Marine	0.8 (0.6-2.2)	0.5 (0.5-1.0)	0.6 (0.4-0.8)	0.6 (0.5-1.2)
De-icing salt	0.6 (0.4-1.0)	0.3	0.4	0.4

3.4 Surface concentration

The surface concentration of *total* chloride to be used in Equation (1) is a *fictitious value* being an extrapolated value from the chloride profile; see Figure 2. Besides, the value often increases with exposure time; Figure 2.

One possibility to define a value of the surface concentration is to use the chloride profile found at the test used for determination of the diffusivity of the repair material (the new cover), δ_{Cl} . From the measured profile of total chloride the surface concentration is extrapolated numerically by use of Equation (1).

Another possibility is to use chloride profiles of unharmed parts of the real structure exposed to the same saline environment as the damaged concrete. Also in this case, the surface concentration has to be extrapolated. This method will give a highest possible value, since the old concrete might be assumed to be of lower quality than the new cover, and the exposure time has been very long.

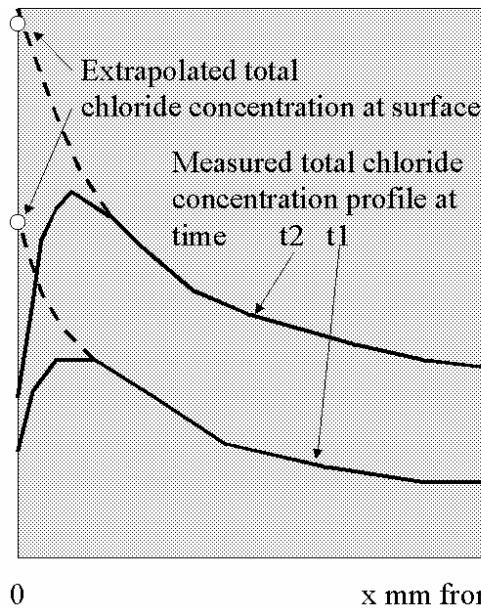

Figure 2: Definition of surface concentration of total chloride.

3.5 Effect of cracks in the cover

If the cover cracks, chloride will enter the cracks and reach the bar quite early. Therefore, it is essential that the new cover does not crack or that no cracks open to the surface are formed at the interface between new cover and old concrete.

Lab tests and exposure tests in nature indicate that cracks will have marginal effects on corrosion resistance provided their width is below ~ 0.2 mm.

It is important that shrinkage and other climate-induced movements are limited so that the cover can stay crack-free. An alternative solution is to add stainless steel fibres to the cover concrete.

Example 2

The required service life of the repaired structure is 40 years ($1.26 \cdot 10^9$ s.)

The structure is placed in the splash zone of seawater.

As repair material concrete with CEM I+15% fly ash is selected. The thickness of the new cover is 50 mm

Chloride diffusivity and surface concentration

A chloride diffusivity test is performed in 1% NaCl-solution (1.7 mole/litre). After 3 months ($7.8 \cdot 10^6$ s) the following total chloride content is observed, by dissolving concrete and using chloride titration:

10 mm from the surface: 0.51 weight-% of cement
20 mm from the surface: 0.15 weight-% of cement

The diffusivity and surface concentrations are obtained by using these values in Equation (1):

$$10 \text{ mm: } 0.8/C_{ls} = \operatorname{erfc}\{0.01/(4 \cdot \delta_{Cl} \cdot 7.8 \cdot 10^6)^{1/2}\}$$
$$20 \text{ mm: } 0.3/C_{ls} = \operatorname{erfc}\{0.02/(4 \cdot \delta_{Cl} \cdot 7.8 \cdot 10^6)^{1/2}\}$$

This equation system is solved by trying different values of the surface concentration C_{ls} , until the same diffusivity is given by both equations. The result is:

$$C_{ls} = 1.1 \%$$
$$\delta_{Cl} = 1.2 \cdot 10^{-11} \text{ m}^2/\text{s}$$

Note

In reality there are many more experimental values than two available. Thus, by comparing all these results with the theoretical chloride profile as given by Equation (1) more safe values of C_{ls} and δ_{Cl} can be obtained. Also, the possible existence of non-linear binding isotherms might be revealed this way.

The threshold concentration

Table 1 gives $C_{thr}=0.6\%$ of the cement weight.

Estimated service life

This can be calculated by Equation (1):

$$0.6/1.1 = 0.545 = \operatorname{erfc}\{0.05/(4 \cdot 1.2 \cdot 10^{-11} \cdot t)^{1/2}\}$$

The service life is **9 years**

Alternative repair

The service life can be extended by two alternatives:

3. Use of cement without pozzolans. This will increase the threshold value.
4. Use of lower w/c-ratio. This will reduce the chloride diffusivity.

The alternative of using another cement is tested. OPC (CEM I) is used. Diffusivity is supposed to be unchanged. Table 1 gives:

$$C_{thr}=0.8\%$$
$$0.8/1.1 = 0.727 = \operatorname{erfc}\{0.05/(4 \cdot 1.2 \cdot 10^{-11} \cdot t)^{1/2}\}$$

The service life is extended to **26 years**. In order to obtain 40 years service life one has to use a more dense concrete with lower chloride diffusivity, $d_{Cl}=9.5 \times 10^{-12}$, or a bigger cover, **65 mm**.

Comment

If a diffusion test with longer duration had been used, the value of the surface concentration, and maybe also the diffusivity, might have been different. Thus, for the same repair material the calculated service life might have been different from the values calculated above. Therefore, it might be better to determine the surface concentrations, not from a diffusion test, but by testing undamaged parts of the old structure.

OPERATIONAL REQUIREMENT 2 SERVICE LIFE WITH REGARD TO COMBINED SALT-FROST ATTACK AND REINFORCEMENT CORROSION

1 Evaluation principles

De-icing salts, or sea water (or other salts in contact with the concrete surface), acting simultaneously with frost, might gradually erode the surface. This makes the cover thinner, and consequently chloride will penetrate the cover to the bars within a shorter time.

Salt-frost scaling can be assumed to occur with constant rate and be described by:

$$x_{sc} = K_{sc} \cdot t \quad (10)$$

The scaling rate is:

$$dx_{sc}/dt = K_{sc} \quad (11)$$

Where:

- x_{sc} the scaling depth during a year [m]
- K_{sc} a constant determining the scaling rate [m/year]
- t the exposure time [years]

The penetration depth of the threshold chloride concentration can be described by; see Equation (1):

$$x_{thr} = K_{thr} \cdot t^{1/2} \quad (12)$$

Then, the penetration rate is:

$$dx_{thr}/dt = K_{thr}/(2 \cdot t^{1/2}) \quad (13)$$

Where:

- x_{thr} the depth of the threshold concentration front from the initial non-eroded surface [m]
- K_{thr} a constant determining the penetration rate [m/year^{1/2}]

Combining the two effects gives the following differential equation for calculating the penetration depth x of the threshold concentration at a given time t , or the service life t for the time when corrosion starts; i.e. when $x=T$ where T is the thickness of the new cover:

$$(x - K_{sc} \cdot t) \cdot (dx_{thr}/dt) = K_{thr}^2 / 2 \quad (14)$$

Where t is time after repair [years].

The equation shows that the effect of frost scaling will be a reduction of service life. This can be calculated by numerically solving Equation (1), provided the two material coefficients K_{sc} and K_{thr} are known. The first coefficient is determined by a salt scaling test. The second is determined by a calculation of the chloride penetration rate as described in the previous paragraph.

Note:

A simpler, but approximate, equation can be derived by calculating how long time it takes until the rate of scaling is equal to the rate of chloride penetration. This time, t^* , is found by putting Equation (11) = Equation (13); i.e.

$$t^* = [K_{thr}/(2 \cdot K_{sc})]^2 \quad (15)$$

At the same time, the depth of the threshold concentration x_{thr}^* is; see Equation (12):

$$x_{thr}^* = K_{thr} \cdot t^{*1/2} \quad (16)$$

After this time, the penetration rate of the threshold concentration is constant and described by the rate of salt scaling. The total time from repair until start of corrosion becomes:

$$t = t^* + (T - x_{thr}^*)/K_{sc} \quad (17)$$

Or, by inserting relations for t^* and x^* and redistributing the terms:

$$t = T/K_{sc} - (K_{thr}/2 \cdot K_{sc})^2 \quad (18)$$

Where T is the cover (thickness of repair).

This equation is easier to use than Equation (14) but it requires the same information; viz. the values of K_{thr} and K_{sc} .

2 Determination of the coefficient K_{sc}

The evaluation requires information of the coefficient K_{sc} determining the scaling rate. This can be estimated from a salt-frost scaling test.

A specimen is exposed to cyclic freezing and thawing in a salt solution. This can consist of de-icing salt (NaCl), or sea-water, or any other salt that is relevant for the structure considered. The salt concentration should be the most harmful (normally ~3% NaCl for de-icing salt) or be the salt concentration of the actual seawater. Each cycle is the same. The minimum temperature is often -20°C or somewhat lower.

The scaling is normally fairly linear for a material with high salt-frost resistance:

$$S = K \cdot N \quad (19)$$

Where:

- S scaling (weight loss) in the test [kg/m²]
- K constant [kg/(m²·cycle)]
- N number of cycles in the test [-]

The result from the scaling test has to be transformed to scaling during natural conditions. Therefore, the lab-cycle has to be transformed to a certain exposure time in the real environment. In reality, each cycle is individual. The minimum temperature varies. An approximate relation between scaling and minimum temperature is:

$$S_{\theta} = S_{\text{test}} \cdot (\theta / \theta_{\text{test}})^2 \quad (20)$$

Where:

- S_θ scaling at one cycle in nature with minimal temperature θ [kg/m²]
- S_{test} scaling at one test cycle in lab. [kg/m²]
- θ the minimum temperature at the cycle in nature [degree]
- θ_{test} the minimum temperature at a test cycle in the lab. [degree]

By Equation (20) the actually occurring F/T-cycles during a year can be transformed to an equivalent number of F/T-cycles in the lab test, N_{equiv} [cycles]:

$$N_{\text{equiv}} = \sum n_i \cdot (\theta_i / \theta_{\text{test}})^2 \quad (21)$$

Where:

- N_{equiv} the number of cycles in the lab test that give the same scaling as real cycles in nature during a year [cycles/year]
- n_i the number of cycles during a year with minimum temperature, θ_i [cycles/year]
- θ_i the minimum temperature of cycle number i in nature [degree]

Then, total scaling during t years is:

$$S_t = S_N \cdot (N_{\text{equiv}} / N_{\text{test}}) \cdot t \quad (22)$$

Where:

- S_t total scaling after t years in nature [kg/m²]
- S_N total scaling after N cycles in the lab test [kg/m²]
- N_{test} number of cycles in the test
- t exposure time [years]

Total scaling depth after t years is found by dividing Equation (22) by density.

$$x_{\text{sc}} = S_N \cdot (N_{\text{equiv}} / N_{\text{test}}) \cdot t / \gamma \quad (23)$$

Where:

- γ density of scaled material [kg/m³]

Then, the coefficient K_{sc} becomes:

$$K_{\text{sc}} = S_N \cdot (N_{\text{equiv}} / N_{\text{test}}) / \gamma \quad (24)$$

3 Determination of coefficient K_{thr}

According to Equation (1) the penetration x at time t of the threshold concentration can be described by:

$$x = \text{Const} \cdot (4 \cdot \delta_{Cl})^{1/2} \cdot t^{1/2} \quad (25)$$

Where the constant depends on the threshold level in relation to the surface concentration, i.e. the ratio (c_{thr}/c_s); see Equation (1).

The coefficient K_{thr} then becomes:

$$K_{thr} = \text{Const} \cdot (4 \delta'_{Cl})^{1/2} \quad (26)$$

Where the diffusivity δ_{Cl}' has the dimension m^2/year instead of the normally used m^2/s . The relation between the two definitions is: $1 \text{m}^2/\text{s} = 3.15 \cdot 10^7 \text{m}^2/\text{year}$

This means that K_{thr} can be determined when the diffusivity of chloride, the surface concentration and the threshold concentrations are known. Methods for determination of these properties are described in *Operational requirement 1* above.

Example 3

The same concrete as in Example 1 Alternative repair. The required cover without synergy is **49 mm**. The service life without synergy is **40 years**. The equation governing the chloride diffusion x versus t is, see Example 1:

$$0.60/0.9 = 0.667 = \text{erfc}\{x/(4 \cdot 5 \cdot 10^{-12} \cdot t)^{1/2}\}$$

But, $\text{erfc}0.31 = 0.667$ according to tables over the complementary error function erfc .

Thus, $0.31 = x/(4 \cdot 5 \cdot 10^{-12} \cdot t^{1/2})$ Or, $x = 0.31 \cdot (4 \cdot 5 \cdot 10^{-12})^{1/2} \cdot t^{1/2}$ when δ_{Cl} is expressed in m^2/s
 $= 5 \cdot 10^{-12} \cdot 3.15 \cdot 10^7 = 1.58 \cdot 10^{-4} \text{m}^2/\text{year}$.

Comparison with Equation (26) gives, $K_{thr} = 0.31 \cdot (4 \cdot 1.58 \cdot 10^{-4})^{1/2} = 7.78 \times 10^{-3} \text{m/year}^{1/2}$

A salt scaling test gives a scaling of $1 \text{kg}/\text{m}^2$ after 56 cycles. The average number of equivalent freeze/thaw cycles in nature is 120. Then, the coefficient K_{sc} becomes, Equation (24):

$$K_{sc} = 1(120/56)(1/2000) = 1.07 \times 10^{-3} \text{m/year}$$

The service life is according to Equation (26) for a cover of 49 mm is

$$T = 0.049/1.07 \cdot 10^{-3} - [7.78 \cdot 10^{-3}/(2 \cdot 1.07 \cdot 10^{-3})]^2 = 32.5 \text{ years}$$

Thus, scaling gives a reduction of service life with **7.5 years**

OPERATIONAL REQUIREMENT 3: SERVICE LIFE WITH REGARD TO COMBINED CHEMICAL SURFACE ATTACK AND REINFORCEMENT CORROSION

1 Evaluation principles

This synergetic effect is fairly improbable since the repair material must be of very high quality to secure service life. Thus, synergy of this type must seldom be considered.

If an evaluation has to be performed, the same type of analysis as described in *Operational requirement 2* is used.

The surface attack will in most cases follow a square-root relation:

$$x_{sa} = K_{sa} \cdot t^{1/2} \quad (27)$$

Where:

K_{sa} = a coefficient describing the rate of surface attack [m/year^{1/2}]

The penetration of the threshold concentration follows Equation (12).

The differential equation describing the combined effect is similar to Equation (14):

$$(x - K_{sa} \cdot t^{1/2}) \cdot (dx_{thr}/dt) = K_{thr}^2/2 \quad (28)$$

The equation assumes that the attacked (destroyed/leached) surface is no hinder to chloride penetration.

This equation can be used for calculating the service life until start of corrosion. The coefficients K_{sa} and K_{thr} must be known

2 Determination of coefficient K_{sa}

The rate of surface attack must be determined by a non-accelerated exposure test. The design of the test is determined by the attack of interest.

2.1 Acid attack

A test method has been suggested in (3). The specimen is placed in the stirred solution. The acid consumption at constant pH of the outer solution is monitored by an automatic burette. The acid consumption can be transformed into a destruction depth, x assuming destruction being a moving boundary process.

From the test data the coefficient K_{sa} can be determined graphically, since Equation (27) will be linear in a log-log diagram with the slope 1/2.

$$\log(x_{sa}) = \log(K_{sa}) + (1/2) \cdot \log t \quad (29)$$

2.2 Leaching

In dense concrete leaching will only affect the outermost millimetre of the cover. Therefore, the effect can normally be neglected.

Tests of leaching can be made by storage of concrete specimens in water of actual quality (acidity and hardness) for a certain time, and then analysing the amount of remaining lime in the concrete as function of the distance from the surface.

Alternatively, the leaching of lime is calculated theoretically assuming it being a diffusive process following a moving boundary process. The rate of penetration of the moving boundary is described by:

$$x = \{ [2 \cdot \delta m (c_0 - c_s) / M_v] \}^{1/2} t^{1/2} = K_{sa} t^{1/2} \quad (30)$$

Where:

- x the depth of the “leaching front [mm]
- δm the diffusion coefficient for leached lime in the concrete surface [m^2/s]
- c_0 the concentration of lime in surrounding water (normally $c_0=0$) [mole/litre]
- c_s the lime concentration of pore water at the leaching front (normally saturated) [mole/litre]
- M_v the total amount of dissolvable lime in concrete [kg/m^3]
- t exposure time [s]

By this equation using measured values for the leaching process K_{sa} can be evaluated.

3 Determination of coefficient K_{thr}

The same technique as described in *Operational requirement 2* is used.

OPERATIONAL REQUIREMENT 4: EVALUATION OF THE SERVICE LIFE OF THE NEW COVER

1 Durability towards frost

Frost might seriously affect the new cover. Typical damage is scaling, cracking, and increase in volume. Scaling will reduce the time to onset of reinforcement corrosion; see *Operational requirement 2* above. The other two types of damage cause increased permeability, which will make chloride ions penetrate easier and, therefore, reduce service life:

The resistance to frost damage of the repair material can be estimated by frost tests. There are two types of test:

- 1: Test of resistance to *external damage* (surface scaling). A method for this type of attack is described in (5). The specimen is pre-conditioned in a precise way. Then, the upper surface is exposed to a 3% NaCl-solution. The specimen is exposed to 56, or more, freeze/thaw cycles between room temperature and at least -20°C . Scaling as function of number of cycles is determined. The maximum scaling to be expected in the field can be estimated by the “exact” Equation (14), or the approximate Equation (18) above.

In this example reinforcement corrosion is of main interest. Therefore, the maximum allowable scaling is determined by its effect on the time to start of corrosion; see *Operational requirement 2* above.

- 2: Test of resistance to *internal damage*. There are a number of test methods to choose between. The best alternative is to use “the critical degree of saturation” –or “critical water content- concept”. One part of the test is to determine the critical moisture content of the cover. The other part is to determine the probable future moisture condition.

Frost resistance, F , can be described by:

$$F = WCR - WACT(t) \tag{31}$$

Where

WCR the critical moisture content above which one single cycle is enough to cause severe damage at freezing

WACT(t) the water content obtained in the field

The material in the cover can be accepted if the critical water content is above the real future moisture condition. If this is not the case, the material in the cover should be rejected.

A way of predicting whether the future moisture condition becomes higher than SCR or not is to extrapolate a long-term laboratory absorption test.

The experimentally determined absorption W_{CAP} can often be described by an equation of the following type:

$$W_{CAP}(t) = A + B \cdot t^C \quad (32)$$

Where

$W_{CAP}(t)$ the water uptake in the material after time t of absorption

A, B, C material dependent coefficients obtained from the absorption curve.

The rate of water absorption is gradually reduced with time, hence $C < 1$.

A value of a sort of *potential service life* is obtained by replacing W_{ACT} in Equation (32) by W_{CAP} expressed by Equation (32) and re-arranging the terms.

$$t_{life,pot} = \{(W_{CR} - A)/B\}^{1/C} \quad (32)$$

Where $t_{pot,life}$ is the absorption time needed for frost damage to occur.

If the amount of water absorbed in the field is believed to be higher than W_{CR} (which means that the really occurring continuous water absorption time is higher than $t_{life,pot}$) the material shall not be used. A material with longer potential service life must be used.

2 Durability towards chemical attack

The cover can be chemically attacked in a way that causes increased permeability and reduced protective capability. Common types of attack for the actual case are:

- * **Sea water.** In order to avoid attack, the binder in the cover shall be sulphate resistant. Tests of sulphate resistance can be made. One can avoid testing by using substituting requirements on the binder used in the cover:
 - For portland cement: $C_3A \leq 3\%$ (DIN-standards)
 - For slag cement: slag content = 70% (*Note:* slag cement often gives reduced salt frost scaling resistance)
- * **De-icing salt attack.** Some de-icing salts will attack concrete by a dissolution reaction. The most frequently used salt of this type is $CaCl_2$. If this salt is used it will, however, also attack not repaired (previously unharmed) parts of the concrete structure. Therefore, this type of attack must always be avoided by avoiding use of these types of aggressive salt.
- * **Cement-aggregate reaction.** Aggregate in the new cover shall not contain alkali-reactive particles. Aggregate can be tested. Reaction can also be stopped by using low alkali cement; Requirement, $Na_2O + 0.66 \cdot K_2O = 0,6\%$.

OPERATIONAL REQUIREMENT 5: EVALUATION OF THE FROST RESISTANCE OF THE OLD (SUBSTRATE) CONCRETE

1 Evaluation principles

The old concrete will become frost damaged when its moisture content exceeds a maximum tolerable -critical- moisture condition. When a new cover of high quality is placed on an old concrete of moderate quality, there is a potential risk that the moisture content in the old concrete will increase. The new cover will not completely stop moisture ingress in the old concrete, but it will retard drying out. Therefore, the moisture balance in the old concrete might be changed in an unfavourable manner.

The risk for this to happen is fairly low, however, when normal concrete without polymer additions is used in the new cover. If the cover concrete is polymer-modified there might be a risk that the frost resistance of the old concrete is impaired. The same is the case when the interface between old concrete and new cover is treated by some sort of polymer improving bond; e.g. epoxy. That this is a risk has been confirmed by tests, (4).

Theoretically, the effect if repair on the moisture conditions could be calculated. In reality this is not possible.

The potential effect of a new surface material placed on an old concrete can be investigated by lab-tests. Examples of tests are given in (4); an assembly consisting of samples drilled out from the old concrete (or manufactured samples of similar concrete), on top of which the repair material to be tested is cast, is exposed to water for a certain time, whereupon it is frost tested in moisture sealed condition. The change in mechanical properties -e.g. dynamic E modulus or speed of sound- is monitored. Un-repaired concrete specimens are compared with repaired. The difference in behaviour indicates effects of the repair.

2 Effect of cracks

If the cover cracks, large amount of water can be transported into the old concrete. Also thin cracks can lead so much water that the old concrete becomes almost saturated for long time. This can be shown by simple theoretical calculations.

Water that has entered through the cracks has difficulties to escape due to the dense concrete in the cover. Therefore, there is an increased risk of frost damage if the cover cracks.

The effect of cracks on the frost resistance of the repaired concrete can be investigated by freeze-thaw tests on pre-cracked specimens. The crack width should not exceed what can be expected in practice.

OPERATIONAL REQUIREMENT 6: EVALUATION OF THE DURABILITY OF BOND

1 The problem

Loss of bond between new cover and sub-base concrete can be caused by a number of mechanisms. The most frequent are:

- 1: Moisture movement (shrinkage-swelling)
- 2: Thermal movement (expansion-contraction)
- 3: Frost action
- 4: Mechanical stresses caused by outer load on the structure

If both the old concrete and the cover are made of concrete, the stresses occurring are normally small. Therefore, the risk of complete loss of bond is normally low for this type of repair.

2 Moisture movement

Free moisture shrinkage of concrete can be related to the water content in the mix; the higher the water content, the bigger the moisture shrinkage. Besides shrinkage increases with decreased relative humidity (RH) of the surroundings. For a water content of 180 litres/m³, non-porous natural aggregate, and RH=50% the free shrinkage is about 0.6‰. At RH=80% - reasonable mean outdoor conditions- the normal free shrinkage is about 0.4‰. These moisture movements can hardly cause loss of bond. Stresses caused by differences in free shrinkage between sub-base concrete and repair material can be calculated by available FEM-programmes. Input information is deformation properties, and shrinkage characteristics of the two materials.

3 Thermal movement

Rapid temperature changes of the surrounding air can cause large temperature gradients in the repaired structure. These can be calculated by available computer programmes. The bond stresses can be calculated by the same methods as stresses caused by moisture movement. Input information is temperature gradients, deformation properties, and coefficients of thermal expansion/contraction.

The risk of loss of bond can also be studied experimentally by cyclically warm and cool the outer surface of a specimen with repaired surface using the actual repair system. Heating can be made by infra-heaters. Cooling can occur naturally in room temperature air. An example of such a test performed for two concrete types covered by a number of cement-based and polymer-based repair materials is shown in (4). The risk of loss of bond was found to be very small.

4 Frost action

This case is discussed above under *Optional requirements 2 and 4*. The risk of loss of bond can be investigated experimentally by freeze/thaw testing combinations of sub-base concrete and repair material.

5 Outer load

Stresses in the interface occurring as a consequence of *normal load* on the repaired structure can be analysed by traditional structural design methods. Such methods will also give the required minimum bond strength needed for the requirements for strength and safety..

Stresses in the interface due to *accidental load* cannot be foreseen.

REFERENCES

- (1) Helland,S.: Chloride penetration into marine structures. RILEM Workshop “Durability of high Performance Concrete”, Vienna February 13-15,1994, Cachan,1994.
- (2) Durable Concrete Structures, Swedish Concrete Association. Report 1, Stockholm, 1998.
- (3) Rombén,L.: Aspcts on testing methods for acid attack on concrete. Swedish Cement and Concrete Research Institute, Research Fo 1:78,Stockholm, 1978.
- (4) Fagerlund,G.,Svensson,O.: Durability of repair systems for concrete balconies. Swedish Cement and Concrete Research Institute, Research Fo 2:80,Stockholm, 1980.
- (5) Swedish Standard SS 13 72 44, “Scaling at freezing”.

ANNEX 3

EVALUATION WITH REGARD TO STRUCTURAL STABILITY AND SAFETY - PROCEDURES

Abstract

This ANNEX is related to paragraph 3 in the Main Document.

Principles for evaluation of the structural stability after repair of different structural elements are presented.

The following structural elements are considered:

- Beams
- Rods
- Slabs
- Panels
- Columns

Repair of *surface damage* and repair of *cracks* are considered.

Reference is made to standards and handbooks, particularly the American Repair Guide ACI 546 R-96 and the European concrete standard.

Contents	Page
1. Preface	4
2. Limitations	4
3. The first step in the evaluation	5
4. Considered damage cases	6
5. Damage cases R1, B1, S1, P1, C1: Superficial damage on tension side	7
6. Damage case R2: Rods with severe damage	7
7. Damage case B2: Beams with severe damage	9
8. Damage case S2: Slabs with severe damage	11
9. Damage case P2: Panels with severe damage	12
10. Damage case C2: Columns with severe damage	13
11. Damage case R3: Rods with cracks	14
12. Damage case B3: Beams with cracks	15
13. Damage case S3: Slabs with cracks	15
14. Damage case P3: Panels with cracks	16
15. Damage case C3: Columns with cracks	16
16. References	17

1. Preface

The purpose of this Annex is to provide the required mechanical performance of the repair system used to restore a damaged concrete structure. Only properties connected to the structural behaviour of the repair are considered.

2. Limitations

As the range of different kinds of structures and damages is very extended, this document will be limited to consider the following *5 types of structures: rods, beams, slabs, panels and columns*. The type of damage may vary a lot. In some cases the affected area may be very limited but the structural damage may be critical anyway. On the other hand a large damaged area does not always jeopardize the static of a structure. A survey of a well-experienced engineer is necessary in any single case to decide the gravity of the damage. To simplify the problem three kinds of damage are distinguished in this document:

- 1) **Superficial damage** of the concrete on the tension side of the section. No damaged concrete closer than approximately 10 mm to steel reinforcement.

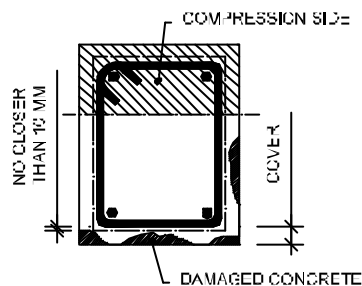

Figure 1: Example of superficial damages

- 2) **Severe damage**: a damage that affects concrete as well as reinforcement bars or any superficial damage on the compression side.

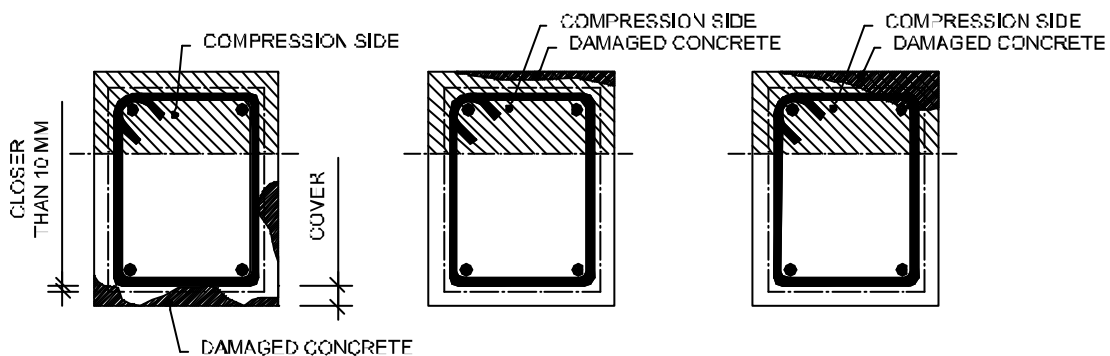

Figure 2: Three examples of severe damage

- 3) **Cracks**. Cracks are to be distinguished in two cases:
 - a. Superficial cracks
 - b. Cracks crossing the entire section of the structure.

3. The first step in the evaluation

The first step is to gather as much information as possible about the damaged structure.

The most important information is to determine the geometry, the material properties, the actual damage, and the load requirements of the structure.

The original structural analysis, design documents as well as the original drawings of the structure, will be very useful in accomplishing this first step.

In some cases, it is not possible to obtain any of the original documents, neither from the local authorities, nor from the owner of the structure. In such a case, it is useful to gather information about which type of constructions was common at the time when the structure was built. This information may be found in books that illustrate previous construction techniques, and in norms that were valid when the original structure was built.

More information about construction details may be collected by in-situ investigation of the structure, and by laboratory tests. Such investigations make it possible to estimate the geometry of the structure, the thickness of the cover, the initial mechanical properties of the concrete and the amount and type of reinforcement.

A first requirement may be that the structure after repair shall be able to take a serviceability load as large as the structure was originally designed for. In lack of original documents a brief calculation may give an indication of what load the structure would be able to carry, had it not been damaged.

In some cases, the owner, or the authorities, may decide to strengthen the structure at the same time as it is repaired, especially if it would not affect the total cost of the repair project significantly. On the other hand, in other cases, the owner may decide to reduce the serviceability load in order to reduce the repair costs.

After a general first survey (A practical technique to do the survey is provided e.g. in references [1] and [2]) it will be possible to determine which parts are damaged. In the case of concrete deterioration and/or reinforcement corrosion, it will be possible to decide what kind of tests it is necessary to make, in order to determine how much of concrete and/or reinforcement that has to be substituted. In many repair projects it is possible to see the full extension of the damage only after that the removal of the damaged concrete has started. In some cases it may turn out that the structure cannot be repaired only after that the concrete removal works are well advanced. That is the reason why it's always very difficult to budget repair works.

At the end of the first step the geometry of the structure, the quality of the materials in the structure, an indication of the extension of the damage and the required load will be known.

4. Considered damage cases

Table 1 shows five types of structures, and damage of three different types. Mechanical requirements for the repair methods applicable to each case will be reported in the following of this document.

The case that best matches the actual project is identified in Table 1.

Table 1: Considered damage cases

Damage type	Type of structure				
	Rod	Beam	Slab	Panel	Column
Superficial damage on tension side	R1	B1	S1	P1	C1
Severe damage	R2	B2	S2	P2	C2
Cracks	R3	B3	S3	P3	C3

5. Damage cases R1, B1, S1, P1, C1: Superficial damage on tension side

Introduction

The procedure described below only applies to the case in which the superficial damage occurs on a side of the structure where the concrete is under tensile stresses, e.g. in the beam mid-section, or above a support in a continuous beam.

For damage in the compression zone, see paragraph 6. (Damage case R2).

Consequences

In the case of superficial damage the design procedure is almost the same for all kind of structures. Superficial damage affects the reinforcement cover. In most cases the function of the cover is to protect the reinforcement from corrosive agents, mechanical damage (traffic/material/water erosion), and fire. The cover also furnishes anchorage of reinforcement.

On the tension side of the construction superficial damages will normally not affect the global strength of the structure.

As only properties influencing structural strength will be discussed, the repair material and method may be designed regardless of strength properties.

Choice of repair system

It will be very important to determine how to perform the repair work, and to determine which kind of repair material may best substitute the damaged concrete. Properties of the repair material as the E-modulus, the coefficient of thermal expansion, shrinkage, creep properties, chemical properties, electrical properties, freeze resistance, permeability etc. may have a decisive impact on the success of the repair depending of the environment surrounding the damaged structure. Information of repair methods is given in reference [3, Chapter 3.4]. A market review of repair methods is presented in reference [7]. A qualitative evaluation of suitable repair systems is made in reference [8].

6. Damage case R2: Rods with severe damage

Introduction

To unload the structure before starting any reparation will make it easier to analyse and predict the behaviour of the combination of the repair material and the existing concrete. If the structure cannot be unloaded the analysis must consider the consequences of the fact that the repair material will not contribute in bearing the forces acting on the structure during the repair works. In order to manage this problem the designer may decide to use post/pretension reinforcement, which will increase the contribution of the new repair material in carrying permanent loads (or any load that cannot be cleared during the repair works). In such a case, it is very important to verify the consequences of the stresses in the existing concrete. A post/pretension repair may lead to failure stresses in the existing concrete if the designer does not consider the strains that post/pretension may cause in the original not removed concrete.

Strength assessment

The condition of the reinforcement and of the concrete section has to be assessed. If the original total reinforcement/concrete area is reduced due to the damage, an analysis is to be done to determine if the damaged reinforcement still may carry the actual ultimate load and limit the crack's size to the required width.

To check the residual load capacity, it is necessary to determine if a compression or tension force acts on the rod.

Information in reference [4, chapter 4.3.5 and 5.4.1] is useful for checking the residual capacity in the case of compression. The check will be performed by using the actual reinforcement and concrete area, in order to take into account the reduction of the bar and rod section caused by the damage. As the severity of the damage usually differs along the considered element, the engineer will choose the most damaged part of the analysed element.

In the case of tension the minimum longitudinal required reinforcement $A_{s,min}$ will be found by $A_{s,min} = N_{Sd} / f_{yd}$. For symbols see reference [4 chapter 5.4.1.2.1].

No strengthening

If the existing reinforcement is still sufficient to carry the ultimate and serviceability load it will be necessary to replace only all the damaged concrete with repair material. The new material is expected to have at least the same mechanical properties as regards tension and compression strength.

Other properties that will affect the success of the repair are discussed in paragraph 5, damage case R1.

With strengthening

In the case the damaged reinforcement is insufficient to bear the ultimate and serviceability load adequately, it will be necessary to apply new or additional reinforcement before proceeding with the repair described above for no strengthening.

The possible alternatives in this case are many. The most common are:

1. *To repair or substitute or add supplemental steel reinforcement within the original section.*

This alternative is treated in reference [3, chapter 2.4]. The suggested methods described there may be implemented in Europe by following the requirements and formulae in reference [4].

Details are to be designed according to reference [4, chapter 5].

2. *To add supplemental reinforcement outside the original section.*

The first step is to restore the concrete section by adequate repair material. Then supplementing reinforcement is applied outside the existing rod. Here it is possible to choose between carbon fibres, steel plates or post tension wires. When using carbon fibres, the design of the repair may follow guidelines in reference [5]. Using conventional steel the new reinforcement may be designed according to methods described in reference [4].

Special care should be taken in designing the anchorage to the original structure. Technique described in reference [4, chapter 5.2.2, 5.2.3, 5.2.5 or 5.3.4] could be applied. A big number of factors will affect this part of the design work: e.g. the kind of reinforcement chosen, the available space, the maximal adhesion strength to the chosen repair material and the actual force to anchor. For further details see reference [3, chapter 5.3].

Depending of the environment the new reinforcement will have to be protected by a cover in order to prevent future damage by corrosion, fire or mechanical action.

3. *Enlarge the rod section by in situ casting of a new bearing element around the existing.*

This structural function of this method does not differ significantly from the previous. The main difference consists in that the new bars or strengthening materials are placed in a form around the existing rod. The form is filled by concrete that will be anchored to the old by pure adhesion or mechanically (e.g. by dowels predrilled in the old concrete). The new bars will be connected to the existing concrete and be protected by the new concrete. Details are to be designed according to reference [4, chapter 5].

7. Damage case B2: Beams with severe damage

Introduction

Comments in *paragraph 6.* apply.

Strength assessment

Comments in *paragraph 6.* apply.

The residual load capacity of the beam will be determined by a structural analysis according to the requirements described in reference [4, chapter 2.5.3.4, chapter 5]. The check is to be performed by using the actual reinforcement and concrete area, in order to take into account the reduction of the bars and beam section caused by the damage. As the severity of the damage usually differs along the considered element, the engineer has to examine several parts of the element in his analysis.

Depending of the actual load, some of the following checks must be done:

1. The ultimate bending moment, see reference [4, figure 4.4, and chapter 4.3.1].
2. The ultimate shear force, see reference [4, chapter 4.3.2].
3. The ultimate torque, see reference [4, chapter 4.3.3].
4. The serviceability stage, see reference [4, chapter 4.4]. Stresses, crack width, deformation, and angle of twist must be analysed.

No strengthening

Comments in *paragraph 6.* apply.

With strengthening

Comments in *paragraph 6.* may apply also to beam repair. In the case of a beam, that is supposed to carry transversal load and therefore be subjected to bending moment it is interesting to investigate the interface between old concrete and repair material.

The beam will act as a monolith if the interface between the two materials is able to forward the longitudinal sliding shear forces to the other (tension/compression) zone of the beam. This is a bond problem that may be solved by calculating the longitudinal shear stresses in the interface.

Once the longitudinal shear stress between new material and existing concrete has been calculated, it will yield the minimal adhesion strength required for the repair material along the interface.

Reference [4, chapter 4.3.2.5] describes how to calculate the mean longitudinal sliding shear per unit length in the case of repair at the compression side. Starting from reference [4, equation 4.33] the value ΔF_d has to be calculated for the portion of the section that is been restored by repair material. The resulting shear flow v_{sd} has then to be divided by the breadth of the interface between repair material and existing concrete.

Figure 3 shows an example of how the shear stress can be calculated in the case of a repair at the compression side. The example is valid only for a case where changes in shear force along length a_v are negligible.

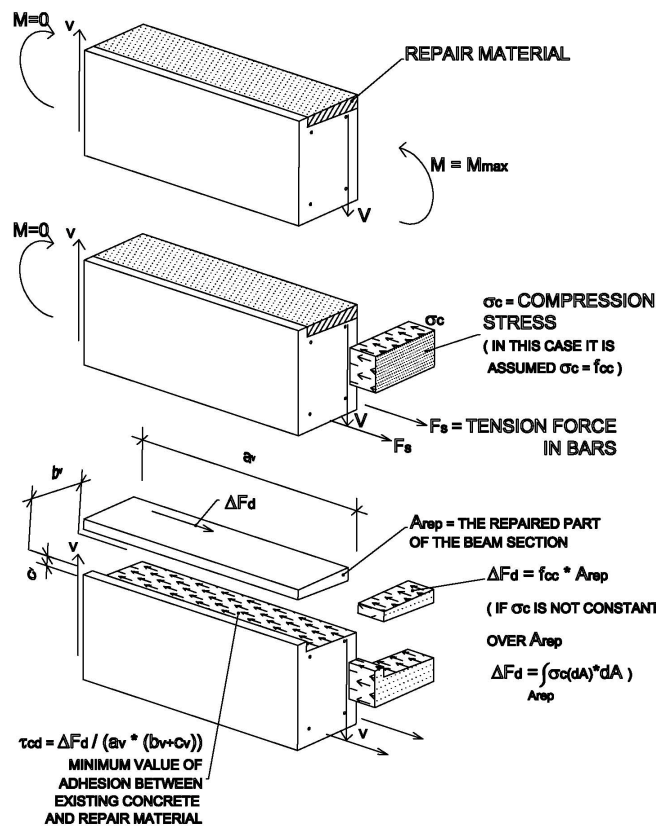

Figure 3: Calculation of the longitudinal sliding shear stress

In the case of a repair at the tension side, the shear flow may be estimated to be as large as the increment of the tension force in the bars included in the repaired part of the section.

If a major longitudinal compression force loads the beam, then see comments in paragraph 10, damage case C2.

8. Damage case S2: Slabs with severe damage

Introduction

Comments in *paragraph 6*. apply.

Strength assessment

Comments in *paragraph 6*. apply.

The residual load capacity of the slab will be determined by a structural analysis according to the requirements given in reference [4, **chapter 2.5.3.5**]. Depending on the actual load, some of the following properties have to be checked:

- 1) The ultimate bending moment, see reference [4, figure 4.4, and chapter 4.3.1].
- 2) The ultimate shear force, see reference [4, chapter 4.3.2].
- 3) The ultimate torque, see reference [4, chapter 4.3.3].
- 4) The ultimate punching shear, see reference [4, chapter 4.3.4].
- 5) The serviceability stadium, see reference [4, chapter 4.4]. Stresses, crack width, deformation, and angle of twist must be analysed.

No strengthening

Comments in *paragraph 6*. apply.

With strengthening

Comments in *paragraph 6*. for rods apply also to the case of slab repair.

Comments in *paragraph 7*. for beams, and principles for calculating the sliding shear stress in the interface between old concrete and new repair material, apply also to slab repair.

Punching shear force

As regards a repair project where the capacity to punching shear load of the slab is to be restored it will in many cases be necessary to temporarily unload the slab by props, in order to prevent any risk of failure during the repair work. Care is to be taken in choosing the dimension and position of the props. Wrong placing of a prop may lead to a punching failure in the slab at the foot or at the top of the prop, jeopardizing the security of people in the building.

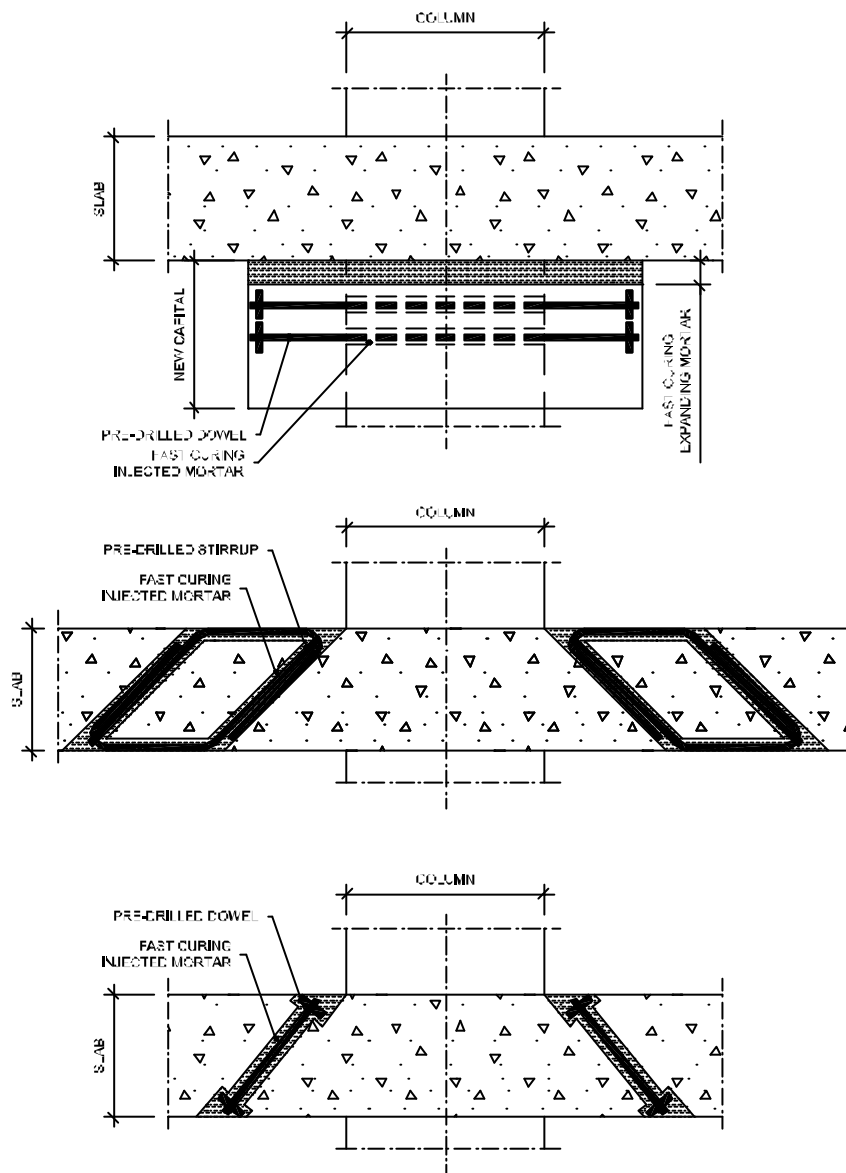

Figure 4: Three examples of strengthening against punching shear.

9. Damage case P2: Panels with severe damage

Introduction

Comments in *paragraph 6.* apply

Strength assessment

Comments in *paragraph 6.* apply.

The residual load capacity of the panel will be determined through a structural analysis according to the requirements in reference [4, chapter 2.5.3.6 and 2.5.3.7.3]. It is very common and convenient to perform the structural analysis through a F.E.M. calculation (Finite Element Method). The result will be predicted normal and shear stresses, which may be compared to the actual quantity of reinforcement existing in the wall. The check

should be performed according to reference [4, chapter A2.9]. In the case of significant concentrated forces applied on a limited part of the wall, it may be necessary to check the risk of buckling failure according to reference [4, chapter 4.3.5].

The capacity of details in the existing reinforcement is to be determined according to reference [4, chapter 5].

The serviceability stadium is to be checked according to reference [4, chapter 4.4].

No strengthening

Comments in *paragraph 6.* apply.

With strengthening

Comments in *paragraph 6.* regarding rods apply also to the case of repair of walls.

As panels are very rigid element, it will be especially important to consider a repair method that allows the finished repair to operate effectively before any crack affects the panel. The very risk in repairing panels is that the repair starts playing a role in carrying the load first after that the original panel has come to failure. To avoid this problem there are several different techniques. The most common are:

- 1) To pre-stress or post-stress the new reinforcement
- 2) To change the static behaviour of the wall by adding new supports
- 3) To unload the panel by props during the repair works
- 4) To design the quantity of new reinforcement taking into account the need to limit the deformations and the cracks in the panel. (This method results in many cases in heavy reinforcement and low stresses in new bars).

10. Damage case C2: Columns with severe damage

Introduction

Comments in *paragraph 6.* apply

Strength assessment

Comments in *paragraph 6.* apply

The residual load capacity of the column will be determined through a structural analysis according to the requirements in reference [4, chapter 4.3.5 and 5.4.1].

The capacity of details in the existing reinforcement is to be determined according to reference [4, chapter 5].

The serviceability stadium is to be checked according to reference [4, chapter 4.4].

No strengthening

Comments in *paragraph 6.* apply.

With strengthening

Comments in *paragraph 6.* apply also to column repair. The design of the strengthening

is to be performed according to the requirements in reference [4, chapter 4.3.5, 5.4.1].

11. Damage case R3: Rods with cracks

Introduction

Cracks may be caused by a number of factors. It is very important to find the cause of the cracks and to determine if the cracks are fully developed or if they are still growing in width. There is no use in repairing any crack if the structure is still moving and the crack is not fully developed. See reference [6, chapter 1-2].

Superficial cracks and cracks through the entire section

Rods are construction elements that transmit only longitudinal forces, compression or tension. Cracks normally appear only in elements subjected to a tensile force. A tension rod is usually designed and reinforced so that the steel bars transmit the entire tension load. If this is the case, the concrete section may have the only function of protecting the steel bars from corrosion, mechanical damage and fire. Cracks may lead to corrosion damage of the steel bars.

If the cracks are caused by yielding in the reinforcement bars (because of too small reinforcement area, or because of overload), it may be necessary to use strengthening of the rod, e.g. by methods described in paragraph 6..

When the cause of the cracks is identified, and arrangements are undertaken in order to prevent the cracks from widening, the repair method can be chosen. The best method depends on the width and extension of the crack. Several methods are reported in reference [6, chapter 3].

The mechanical properties of the repair material (injection material) are significant in the case of a rod loaded by a compression force. In this case the compression strength of the injection material must be at least as high as the original concrete.

Cracks in compression rods are unusual, but there are cases when rods are alternatively loaded by tension and compression forces at different load-cases.

12. Damage case B3: Beams with cracks

Introduction

See comments in paragraph 11.

Cracks caused by section forces and insufficient reinforcement may be repaired after that the beam has been strengthened. Special attention should be paid to cracks that can be suspected to depend on shear forces. Comments on strengthening in paragraph 7. apply.

Superficial cracks

Repair of beams damaged by shallow cracks is to be performed with a material that has at least the same properties as regards compression and tension strength as the original concrete.

Cracks through the entire section

The repair of beams damaged by cracks that pass the section from side to side is to be performed with a material that has at least the same properties as regards compression and tension strength as the original concrete. The minimum bond properties required may be set equal to the maximum shear stress in the section. The most appropriate repair method may vary according to the width and extension of the crack. Several alternatives are given in reference [6, chapter 3].

13. Damage case S3: Slabs with cracks

Introduction

Comments in paragraph 11. regarding rods apply

Cracks caused by section forces and insufficient reinforcement may be repaired after that the slab has been strengthened. Special attention should be paid to cracks that can be suspected to depend on punching forces or shear forces. Comments about strengthening are found in paragraph 8.

Superficial cracks

Comments in paragraph 12. regarding beams apply.

Cracks through the entire section

Comments in paragraph 12. regarding beams apply.

14. Damage case P3, C3: Panels and Columns with cracks

Introduction

Comments in paragraph 11. regarding rods apply.

Cracks caused by section forces and insufficient reinforcement may be repaired after that the panel has been strengthened. Special attention should be paid to cracks that can be suspected to depend on shear forces. Comments on strengthening are found in paragraph 9.

Superficial cracks

Comments in paragraph 12. regarding beams apply.

Cracks through the entire section

Comments in paragraph 12. regarding beams apply.

15. damage case C3: Columns, cracks

Introduction

Comments in paragraph 11. regarding rods apply.

Cracks caused by section forces and insufficient reinforcement may be repaired after that the column has been strengthened. Comments on strengthening are found in paragraph 10.

Superficial cracks

Comments in paragraph 12. regarding beams apply.

Cracks through the entire section

Comments in paragraph 12. regarding beams apply.

References

- [1] ACI 201.1 R-92 “*Guide for Making a Condition Survey of Concrete in Service*”.
- [2] ACI 207.3 R-94 “*Practices for Evaluation of Concrete in Existing Massive Structures for Service Condition*”.
- [3] ACI 546 R-96 “*Concrete Repair Guide*”.
- [4] ENV 1992-1-1:1991. Chapter 3.3.
- [5] Täljsten, B.: “*FRP Strengthening of Existing Concrete Structures Design Guidelines*”, 2002 Luleå University of Technology
- [6] ACI 224.1 R-93 “*Causes, Evaluation and Repair of Cracks in Concrete Structures*”.
ACI 224R-01 “*Control of Cracking in Concrete Structures*”.
- [7] REHABCON. Work Package WP2.1, “*Market Review*”. Geocisa, Madrid, 2002.
- [8] REHABCON. Work Package WP2.3, “*Evaluation of Repair. Deliverable D1, Evaluation with regard to durability and service life. Main Document. Appendix*”. Lund, 2003.

ANNEX 4

EVALUATION WITH REGARD TO EXECUTION OF WORK EVALUATION OF FREQUENT ACTIONS

Abstract

This ANNEX is related to paragraph 4 in the Main Document.

Execution of work is divided in 12 different *actions*. Each of these is divided in 8 different *characteristics*. Examples are effect of the action on *work environment*, influence of *climatic conditions* on the action, *speed* of operation, influence of the action on the *quality of the finished structure*.

The evaluation is qualitative and is shown in a number of tables, one for each action.

Introduction

Execution of repair work is divided in a number of *actions*:

1. Removal of damaged concrete
2. Application of material replacing the old concrete
3. Injection
4. Replacement and additional reinforcement
5. Use of chloride extraction and re-alkalisation
6. Application of cathodic protection
7. Cleaning of concrete surface
8. Drying of concrete surface
9. Application of non-structural surface layer on the cover
10. Application of structural surface layer on the cover
11. Cleaning of reinforcement
12. Application of inhibitors

Each of these actions can be performed by different techniques. Each of these has its advantages and drawbacks. These are described in tables below.

Each action is divided in 8 *characteristics*:

1. Work environment
2. Non-technical issues including effect on outer environment
3. Climatic conditions
4. Application simplicities/difficulties
5. Applicability with regard to type of structure
6. Need of additional equipments
7. Speed of operation
8. Influence on properties of the structure

The evaluation made in the tables is very *qualitative* and can only be used for a first evaluation. Each action can be performed in a number of ways with different materials, different equipments, etc. Therefore, the information in the tables must be supplemented by more information relevant for each actual case.

Action 1: Removal of damaged concrete.

Method	Working environment	Non-technical issues	Climatic conditions	Application Simplicities/difficulties	Applicability with regard to type of structure	Need of additional equipment	Speed of operation	Influence on properties of the structure
Blasting	Creates dust and noise. If the surface is contaminated additional protection is required.	Applied to infrastructure construction the method may cause disturbance of traffic and create dust and noise.	No restrictions.	Suitable for removing thin concrete layers.	Applicable to all types of structures.	Scaffolding may be needed for vertical structures. Equipment for suction of dust often needed.		Micro-crack free surface. Good bond properties. Takes away stain from reinforcement.
Milling	See blasting	See blasting	No restrictions.	Suitable for making grooves for additional reinforcement. Suitable for removing limited and thin concrete layers	See blasting Suitable for making grooves for additional reinforcement.	See blasting.		See blasting
Mechanical Hammering	See blasting. Also vibrations and noise	See above. Also heavy noise.	No restrictions.	Suitable for removing thick concrete layers. Applicable for making grooves for additional reinforcement.	See blasting.	See blasting.		Partly damages the remaining concrete. May damage the reinforcement.
Water-jetting	No dust, low noise and no vibration.	Minor disturbance. If the surface is contaminated the water should be taken care of.	Freezing risk at low temperature	See mechanical hammering.	See blasting. Should be used with care for indoor structures.	Scaffolding may be needed for vertical structures. Water must be taken care of in indoor work	Rapid method.	See blasting.
Grinding	See mechanical hammering.	See blasting.	No restrictions.	See blasting.		See blasting.		See blasting.
Sawing	See blasting.	See blasting.	No restrictions.	Suitable for removing parts of the structure/ structural members. Suitable for making grooves for reinforcement.	See blasting.	See blasting.		See blasting.
Drilling	See mechanical hammering.	See mechanical hammering.	No restrictions.	Suitable for making openings and grooves for reinforcement.	See blasting.	See blasting.		See blasting.

Action 2: Application of material replacing the old concrete

Material	<i>Work environment</i>	<i>Non-technical issues</i>	<i>Climatic conditions</i>	<i>Application simplicities/difficulties</i>	<i>Applicability with regard to type of structure</i>	<i>Need of additional equipments and requirements</i>	<i>Speed of operation</i>	<i>Influence on properties of the structure</i>
Portland Cement Concrete (PC-concrete)	Cement is irritating to skin. Chromate in cement can cause allergy.		5-32 °C	Vibration is necessary. Skilled workers required. Careful control needed.	It is applicable for all kinds of concrete structures. Recommended for large areas.	Previous preparation of substrate needed. Can be pumped or shotcreted. Formwork needed. At least 7 days of moist curing.	7-28 days before full strength.	Chemical, mechanical and physical properties are similar to the substrate concrete. Properties can be varied by changes in the mix composition.
Portland Cement Mortar	See PC-concrete.		5-32 °C	See PC-concrete.	see PC-concrete. Layers must be thick.	Previous preparation of substrate needed. Can be pumped or shotcreted. Formwork needed. At least 7 days of moist curing.	See PC-concrete.	See PC-concrete.
Portland cement grouts	See PC-concrete.		5-32 °C	See PC-concrete. Water-cement ratio must be low to minimize shrinkage. This might cause stiff mixes.	Good for sealing dormant cracks and filling voids inside the structure.	Previous preparation of substrate needed. Formwork needed. Can be pumped. Curing as for PC.	See PC-concrete.	See PC-concrete. Shrinkage often bigger than ordinary concrete. If cracks cannot be sealed, repair can be only partially effective.
Portland cement with mineral or chemical admixtures	See PC-concrete. Fly ash can cause respirable dust. Approved admixtures are safe.		5-35 °C	See PC-concrete. Concrete with anti-washout admixtures can be used for underwater repair. Different chemical admixtures give concrete with different properties as regards application.	See PC-concrete.	Previous preparation of substrate needed. Curing as for PC.	See PC. Mineral admixtures retard hardening, especially at low temperature	See PC-concrete. Compensated shrinkage can be obtained by special cements or additives.
Portland cement with polymers (Polymer-modified PC)	See PC-concrete. Approved polymers are safe.		7-35 °C	Repairs must not be featheredged.	Can be applied in patches thinner than conventional concrete.	Previous preparation of substrate needed. Curing as for PC.	Fast setting.	Strength and adhesion can be improved.

Action 2: Application of material replacing the old concrete (continued)

Material	<i>Work environment</i>	<i>Non-technical issues</i>	<i>Climatic conditions</i>	<i>Application simplicities/difficulties</i>	<i>Applicability with regard to type of structure</i>	<i>Need of additional equipments and requirements</i>	<i>Speed of operation</i>	<i>Influence on properties of the structure</i>
Epoxy resin mortars	Non-reacted mater. can cause allergy.		6-25 °C	Substrate must be dry Epoxy resins are hard to apply under 16 °C Short "pot-life".	Suitable for thin layers. Appropriate only for small areas.	Previous preparation of substrate needed. Bonding agent (primer) needed.	Fast setting.	Low E-modulus. Vulnerable to acids, high temperatures, and sun rays Good abrasion resistance.
Acrylic resin mortars	See epoxy .		5-35 °C	Substrate must be dry. Tixotropic. Short "pot-life".	See Epoxy resin Mortars.	Previous preparation of substrate needed. Bonding agent needed.	Fast setting.	Low E-modulus. Vulnerable to temperatures higher than 60 °C (continuous exposure) and 100 °C (brief exposure).

Action 3 part 1: Injection procedure

Method	<i>Work environment</i>	<i>Non-technical issues</i>	<i>Climatic conditions</i>	<i>Application simplicities/difficulties</i>	<i>Applicability with regard to type of structure</i>	<i>Need of additional equipments and requirements</i>	<i>Speed of operation</i>	<i>Influence on properties of the structure</i>
From the surface	See Action 3 Part 2	Low consumption of product. Injection materials are not reusable.	Depends on material.	The injection pressure in the cracks is not adjustable. Depth of penetration is not controllable.	Distance between injectors varies depending on the dimension of cracks	Previous sealing and cleaning of cracks needed. Pumps are needed	Rapid execution	Cracks are sealed. Reduces ingress of water and chloride. Increases structural capacity of the structure.
Internal injection	See Action 3 Part 2	High consumption of injection material. Produces dust when drilling.	Depends on material.	Allows high pressure injection. Depth of penetration is better controlled. Requires skilled workmanship.	If cracks are still active, injection is useless.	Sealing, and cleaning of cracks and drilling are needed prior to the injection. Pumps are needed.	Higher than the injection from the surface.	See above. Use of excessive pressure can make cracks propagate.

Method	<i>Application simplicities/difficulties</i>	<i>Applicability with regard to type of structure</i>	<i>Need of additional equipments and requirements</i>	<i>Speed of operation</i>	<i>Influence on properties of the structure</i>
Low pressure injection	Allows use of easily removable materials for sealing. Systems are portable. Skill of workmanship is not critical.	Requires materials with a long pot life (> 1 hour).	Pumping systems	Much slower than the high pressure injection for the same results.	Cracks become closed.
High pressure injection	Skill of crew is critical. Requires aggressive removal of seals.	Can use materials with a short pot life. Too much pressure can make cracks propagate.	Pumping systems more complex than above.	Fast method.	Same results as for low pressure, but achieved faster

Action 3 part 2: Materials for injection

Method	<i>Work environment</i>	<i>Non-technical issues</i>	<i>Climatic conditions</i>	<i>Application simplicities/difficulties</i>	<i>Applicability with regard to type of structure</i>	<i>Need of additional equipments and requirements</i>	<i>Speed of operation</i>	<i>Influence on properties of the structure</i>
Epoxy resin	Non-reacted epoxy can cause allergy. Protection required.		6-25 °C	Cracks must be dried out and sealed on all sides. If cracks are still leaking these materials are not applicable. If low pressure injection is used, long pot life is necessary.	Recommended only for dormant cracks. Applicable to cracks as narrow as 0,05 mm	Epoxies can be pumped.		Cracks are sealed. Reduces ingress of water and chloride. Increase structural capacity of the structure. Forms a monolithic structure.
Polyurethane resin	Isocyanate used in some products is toxic. Protection required.		> 5 °C	Pre-sealing of cracks not necessary. Must be injected at high pressure.	Minimum width of crack is 0,2 mm.	Pumping device needed		See above. Seals active cracks.
Cement suspensions	Cement is irritating to skin. Chromate in cement can cause allergy.		5-35 °C	Best applied at low pressure. Does not completely fill the crack. Can be applied on moist cracks.	Minimum width of crack is 0,2 mm.	Can be pumped		See above

Action 4: Replacement of reinforcement, and additional reinforcement

Method	<i>Work environment</i>	<i>Non-technical issues</i>	<i>Climatic conditions</i>	<i>Application Simplicities/difficulties</i>	<i>Applicability with regard to type of structure</i>	<i>Need of additional equipments and requirements</i>	<i>Speed of operation</i>	<i>Influence on properties of the structure</i>
Non-stressed conventional reinforcement		May cause disturbance of traffic when applied to infrastructure constructions.		A new concrete cover must be cast outside the new reinforcement for anchoring and corrosion protection. Often the structure must be unloaded before application of reinforcement.	Applicable to all types of structures	Equipment for removing old concrete or making ducts for the new bars. Drilling equipment. Pumping equipment. Sealing of cracks is sometimes needed.	Fast	Load-bearing capacity restored or increased.
Non-stressed stainless steel reinforcement		See above.		See above. The new cover can sometimes be thinner than for conventional reinforcement. Expensive.	Applicable to all types of structures. Most appropriate at exposure to high permanent chloride load (marine structures).	See above.		See above.
Post-tensioned reinforcement		See above. Can alter the geometry and aesthetics of the structure.		Unloading may be required sometimes. Some abutment is needed for anchorage. Reinforcement must be placed externally. Needs careful design. Corrosion protection is required.	Most applicable to beams and slabs.	Post-tensioning equipment. Injection device for ducts.	Slow	See above. Cracked sections become monolithic.

Action 4: Replacement of reinforcement, and additional reinforcement (continued)

Method	<i>Work environment</i>	<i>Non-technical issues</i>	<i>Climatic conditions</i>	<i>Application Simplicities/difficulties</i>	<i>Applicability with regard to type of structure</i>	<i>Need of additional equipments and requirements</i>	<i>Speed of operation</i>	<i>Influence on properties of the structure</i>
Pre-stressed steel		See above		Unloading may be required sometimes. Adequate anchorage is needed. Corrosion protection is required. Needs careful design. Deviators and anchor plates have to be placed accurately.	Most applicable to beams and slabs.	Pre-stressing device. Injection device for ducts.	Slow	See post-tensioning. Increased bending and deflection capacity.
Steel plates glued to the surface	Non-reacted epoxy used as adhesive can cause allergy. Protection is required.	May cause disturbance of traffic when applied to infrastructure structures.	Epoxy cannot be used below 5° C	Degraded concrete must be removed. Surface concrete must be made even. Epoxy and similar adhesives requires clean and dry surface. Unloading of the structure often needed. Width of plates should be over 200 mm. Plates are joined to concrete with mechanical anchors and epoxy adhesive. Plates must be protected against fire.	Concrete quality must be over 17,5 MPa. Not recommendable where temperatures over 55 °C are expected.	Steel plates are heavy, so cranes are usually needed. Drilling equipment for anchors.	Slow	Load carrying capacity can be heavily increased. Steel plates can suffer by corrosion and fatigue

Action 4: Replacement of reinforcement, and additional reinforcement (continued)

Method	<i>Work environment</i>	<i>Non-technical issues</i>	<i>Climatic conditions</i>	<i>Application Simplicities/difficulties</i>	<i>Applicability with regard to type of structure</i>	<i>Need of additional equipments and requirements</i>	<i>Speed of operation</i>	<i>Influence on properties of the structure</i>
FRP applied to the surface	See above. Other adhesives than epoxy might be harmful to man.	See above.	See above.	FRP are bonded to the concrete with epoxy adhesive. Degraded concrete must be removed. Surface concrete must be made even. Sandblasting may be required. Epoxy and similar adhesives requires clean and dry surface. Unloading of the structure is often needed.	Tensile strength of concrete must be >1 MPa . FRP must be protected from fire and sun.	Equipment for rinsing, cleaning and roughening of substrate.	Faster than above	Flexural and shear capacity can be increased considerably.

Action 5: Use of chloride extraction and Realkalisation

These methods are sophisticated, complicated and seldom used. Know-how is primarily restricted to companies marketing the methods. Therefore, a general evaluation of execution cannot be performed.

Action 6: Application of cathodic protection

The method is sophisticated and complicated. Know-how is restricted to companies marketing cathodic protection systems. Therefore, a general evaluation of execution cannot be performed.

Action 7: Cleaning of concrete surface

Method	<i>Work environment</i>	<i>Non-technical issues</i>	<i>Climatic conditions</i>	<i>Application simplicities/difficulties</i>	<i>Applicability with regard to type of structure</i>	<i>Need of additional equipments and requirements</i>	<i>Speed of operation</i>	<i>Influence on properties of the structure</i>
Mechanical cleaning (steel-brushing, etc.)	Creates dust and noise. Heavy work load.		No restrictions	Specialized crew is a must. Roughness of surface depends on selected hammer head.	Too expensive if the area to clean is large.	Must often be followed by water jetting or blasting for final cleaning.	Fast	Can cause micro-cracks in the concrete
Chemical cleaning	Protection might be needed if chemicals are toxic or irritating.		> 0 °C	All remaining traces of the cleaning agent must be removed.	Solvents should not be used as they can help existing contaminants to penetrate deeper into the concrete	Equipment for flushing with clean water		Removes oil, grease and dirt.
Dry sandblasting	Creates dust and noise. Operator must be equipped with a respirator device.	Applied to infrastructure construction the method may cause disturbance of traffic and create dust and noise	No restrictions	The particle size of the abrasive must be selected with regard to the substrate. Soft abrasives may be destroyed rapidly. Produces airborne particles Used abrasives must be removed.	Very effective as the final step of a surface preparation.	Compressor producing oil free air.	Fast	Produces a textured, sound concrete free from surface contamination and fines.
Wet sandblasting	Creates less dust than dry sandblasting	Applying for infrastructure construction it may cause disturbance of traffic and create dust and noise	>0 °C	See above.	See above.	Compressor producing oil free air.	Fast	See above.

Action 7: Cleaning of concrete surface (continued)

Method	<i>Work environment</i>	<i>Non-technical issues</i>	<i>Climatic conditions</i>	<i>Application simplicities/difficulties</i>	<i>Applicability with regard to type of structure</i>	<i>Need of additional equipments and requirements</i>	<i>Speed of operation</i>	<i>Influence on properties of the structure</i>
Water jet blasting	No dust or noise, or vibration.	If surface is contaminated, waist water must be taken care of	> 0 °C	Water alone may be not effective enough.	See above.	Possibility to add abrasives to water	Fast	Leaves concrete surface clean and dust free Water jetted surfaces provide excellent bond strength.
Acid etching	Acid can be etching and irritating.	Requires waste management	> 0 °C	All traces of acid must be removed.	Effective against laitance layer and surface dirt.	Requires previous chemical cleaning		Acid provides a roughened substrate.
Steam cleaning	See water jetting	See water jetting	> 0 °C	Only removes surface contaminants.	This method is effective only for water soluble contaminants	Detergents or others chemicals can be added to water	Fast	Contaminants remain in the pores of concrete.

Action 8: Drying of concrete surface

Drying is normally not required, especially not when new concrete is to be cast on the old. If drying is to be made, for instance in conjunction with casting a polymer concrete on the old concrete, or when the new concrete cover is to be supplied by a coating for aesthetical or other reasons, it might be necessary to make a certain drying to a certain depth. In some cases it is enough if the surface is “surface-dry”. In other cases drying shall proceed until the relative humidity of the uppermost centimetres is below a certain value, often 80% to 90% RH. The requirement must be prescribed by the manufacturer of the repair material.

Natural drying by evaporation to surrounding air needs no equipment, but might be time-consuming. Time needed depends on weather conditions, quality of concrete, and required RH-level.

Accelerated methods for drying are either, (i) heating the concrete under isolated shelter, or (ii) de-watering concrete by de-sorption aggregate under tight shelter. Both methods can be used under all climate conditions. De-watering needs less energy but is more slow. An advantage of this method is that the temperature of the concrete is not raised. Therefore, no rapid changes in RH occur after terminated drying. Equipment for measuring RH inside the concrete is required in order to verify that the correct RH-level has been reached, so that drying can be terminated.

Action 9: Application of non-reinforcing surface layer on the cover

Method	<i>Work environment</i>	<i>Non-technical issues</i>	<i>Climatic conditions</i>	<i>Application simplicities/difficulties</i>	<i>Applicability with regard to type of structure</i>	<i>Need of additional equipments and requirements</i>	<i>Speed of operation</i>	<i>Influence on properties of the structure</i>
Hydrophobic impregnation	Impregnation products can be toxic.	Products can be flammable.	5-30 ° C Humidity < 70 %	Surface must be dry and clean.	Pull-off strength of concrete must be over 1.5 N/mm ² . Impregnation must be compatible with substrate	Products can be sprayed or applied with a brush	Fast	Increases resistance to uptake of liquid water but lets water vapour pass. Thus, lowers internal moisture level. Reduces ingress of chloride. Appearance is not affected
Impregnation	See above.	See above.	No restrictions	See above.	See above.	See above	Fast	The same as above. Reduces surface porosity.
Cement based coating	Cement is irritating to skin. Chromate in cement can cause allergy.		5-35 °C		See above. Thickness of coating will be selected with regard to desired protection (0,1-5 mm).	See above.	Fast	Might reduce water uptake in concrete. Might somewhat retard ingress of chloride and CO ₂ . Can be decorative.
Polymer-based coating	Polymers can be toxic	Products can be flammable	16-32 ° C	Surface must be dry and clean. Concrete curing must be finished. Thick sections of neat epoxy are likely to crack. If concrete cracks contain moisture the monomer will not be soaked in reducing the filling of the cracks.	Pull-off strength of concrete must be over 1,5 N/mm ² Coating must be compatible with substrate concrete.	See above.	Fast	Protects the concrete against chemical attack. Retard ingress of chloride and CO ₂ . Coating forms a vapour barrier and can trap water if the structure is not sealed in all parts. Frost damage might occur. Can seal narrow cracks (< 0,8 mm)

Action 10: Application of reinforcing surface layer on the cover

These are special techniques often performed by specialised companies. Therefore, a general evaluation of execution of work cannot be performed. See also FRP in Action 4.

Action 11: Cleaning of reinforcement

Method	<i>Working environment</i>	<i>Non-technical issues</i>	<i>Climatic conditions of use</i>	<i>Application Simplicities/difficulties</i>	<i>Applicability with regard to type of structure</i>	<i>Need of additional equipments and requirements</i>	<i>Speed of operation</i>	<i>Influence on mechanical properties</i>
Dry sandblasting	Creates dust and noise. Operator must be equipped with a respirator device.	Applied to infrastructure construction the method may cause disturbance of traffic and create dust and noise.	No restrictions	Excellent method to remove heavy rust. Removal of rust from the underside of the bars must rely on sand rebounding from the substrate. Bars must be covered by concrete short time after blasting. Produces airborne particles. Used abrasives must be removed.	Good for large areas. Does not remove oil, grease, etc.	Compressor producing oil-free air.	Fast	.
Wet sandblasting	Less dust than above.	See above.	>0 °C	Not as good method as above. Removal of rust from the underside of the bars must rely on sand rebounding from the substrate. Bars must be covered short time after blasting.	See above.	See above.	Fast	

Action 11: Cleaning of reinforcement (continued)

Method	<i>Working environment</i>	<i>Non-technical issues</i>	<i>Climatic conditions of use</i>	<i>Application Simplicities/difficulties</i>	<i>Applicability with regard to type of structure</i>	<i>Need of additional equipments and requirements</i>	<i>Speed of operation</i>	<i>Influence on mechanical properties</i>
Water-jet blasting	No dust, no noise	Used water must be collected	>0 °C	Not as good method as above. Removal of rust from the underside of the bars must rely on water rebounding from the substrate. Bars must be covered short time after.	Good for large areas	Operator must wear protecting glasses. Compressor producing oil-free air.	Fast	
Wire brushing	No dust, no noise. Requires high physical effort from workers		No restrictions	Appropriate only for light to moderate rust. Brushing must be vigorous. Removing rust from the underside of bars can be difficult.	Only on limited areas where blasting would be uneconomical.		Slow	
Sand paper	See above	See above	See above	Appropriate only for light to moderate rust. Less effective than wire brushing. Requires more effort than wire brushing. Bars must be covered short time after cleaning.	See above.	See above.	Slow	
Rust converters	No dust, no noise		Temperature of metal must be over 10 °C and below 35°	Rust must be previously cleaned from dust, grease, and soluble salts	Uneconomical on large areas.	Applied by brushing, spraying, roller coating, etc.	Slow	Neutralized rust protects iron from further corrosion.

Action 12: Use of inhibitors

Evaluation of execution of work connected with the use of inhibitors cannot be performed due to lack of reliable information. The work procedure and health hazards in connection with use has to be described by the manufacturer of the inhibitors.

ANNEX 5

EVALUATION WITH REGARD TO ENVIRONMENT AND HEALTH

Abstract

This ANNEX is related to paragraph 5 in the Main Document.

General principles for evaluation of activities with regard to environmental impact are described. Methods treated are:

- Life cycle assessment (LCA)
- Environmental risk inventory (ERI)
- Environmental indicators

Application of these principles to the *concrete repair process* is made. It is distinguished between.

- Evaluation with regard to outer environment.
- Evaluation with regard to indoor environment.

Important information needed for these evaluations is provided in “ecology declarations” and “indoor declarations”. The contents of these are described.

The evaluation procedure is illustrated by a practical example.

Contents

1	Introduction	4
2	General methodology for evaluation	4
2.1	<i>Methods for evaluating environmental impact</i>	4
2.1.1	Environmental Impact Assessment	5
2.1.2	LCA; Life Cycle Assessment	5
2.1.3	Environmental risk inventory	6
2.1.4	Environmental indicators or headline indicators	7
3	Evaluation of concrete repair process	7
3.1	<i>Evaluation of concrete repair – ecology</i>	10
3.1.1	Life cycle phases	11
3.1.2	Effect on ecology	12
3.1.3	Declaration principles	13
3.1.4	Content of ecology declaration	14
3.2	<i>Evaluation of concrete repair – indoor environment</i>	18
3.2.1	Indoor environment parameters	18
3.2.2	Content of indoor declaration	20
3.3	<i>Evaluation of concrete repair – health and safety</i>	21
3.3.1	Health and safety parameters	21
4	Example	23
5	References	26

ENVIRONMENT AND HEALTH

1. Introduction

In the evaluation process it's important that environment and health factors are considered in the whole concrete repair life cycle – from the production of repair material to demolition and waste disposal. This part is a description on how such an evaluation can be done.

We have to face the fact that the experience of this type of evaluations is relatively short and the technique is still developed within many types of industry and processes. It can also be stated that a lot of facts and figures are still missing meaning that today it's not possible to make a complete evaluation resulting in figures for different impact like emissions into air and water, energy consumption etc. However it can serve as a useful tool for comparing different repair methods from an environmental aspect. The evaluation process can also serve as a type of environment and health checklist for concrete repair methods.

Instead of starting with complicated and extended evaluation processes with high risk of giving misleading results it's therefore recommended to start with checklists and relatively simple comparisons of different repair methods.

Another important point is the lifetime of the evaluated concrete repair method. The impact on environment and health has a very strong relation to the lifetime of the repair. When comparing different repair methods it has to be done based on the expected lifetime of the repair. In a comparison "Method 1" could be evaluated as more environmental friendly than "Method 2" but if the lifetime for "Method 2" is expected to be twice that of "Method 1", the total effect could be more favourable with Method 1.

The methods described here should therefore be used with "common sense". It's recommended to start with a survey to find the most important questions and risks connected to the evaluated repair process. In a next step these points could be further investigated and evaluated before a final decision can be made.

2. General methodology for evaluation

The most ultimate method for evaluating the environmental effect would be an Environmental Impact Assessment (EIA) or a Life Cycle Analyses (LCA). For some reasons (see below) these methods are considered to be too extensive to be applicable on concrete repair.

2.1 Methods for evaluating environmental impact

This is a description of some methods for evaluating and estimating environmental impact, and some comments on the suitability of the different methods in this case.

2.1.1 Environmental Impact Assessment

The development of Environmental Impact Assessment, EIA, started in the US in the 60's aiming at reaching environmental goals and leading to more democratic decision processes. When planning certain projects, such as building a factory, a power plant or a road it is required by law to carry out an EIA. Since 1999, when the new Swedish Environmental Protection Act came into practice, EIA is a requirement in all projects that will have an effect on the environment. The Swedish EIA can be described as three things; a process, a document and the underlying data in the decision making process.

The aim of an EIA is to identify and describe the direct and indirect effects a planned activity or measure may have on humans, animals, plants, ground, water, air, climate, landscape, and cultural heritage as well as natural resources and energy. The overall aim is to facilitate a cumulated judgement of the effects on human health and environment. The object of studying is a planned project (e.g. golf course, roads). EIA should be integrated in the entire planning process. The result of an EIA is site specific.

There is no "set of rules" on how to perform an EIA, therefore it is commonly referred to as a "process" rather than a tool or a method. There are no rules on which environmental aspects that are to be included in an EIA, it is decided in each case. When performing an EIA a number of methods can be used and the results may vary.

The method is used by companies, communities or authorities when applying for permission for a planned project. An EIA is supposed to predict effects of the planned activity and also present alternative solutions on location and performance. A zero-alternative shall also be included, which is the alternative when the already existing activity (or lack of activity) goes on.

Since EIA is site specific, and more of a process than a method, it can not be applied in the evaluation of a repair method. However, some of the methods used when performing an EIA may be suitable.

2.1.2 LCA - Life Cycle Assessment

In an LCA the potential environmental effects of a "product" are studied during its entire life cycle, "from cradle to grave". The product may be a material product but also a service or a production method. Products that are studied could for example be "taking care of a kilo of waste", "producing 1 kWh of hydropower", "producing 1 kWh of nuclear power", "1 kilo of ketchup" or "1 km road".

The method takes the entire life cycle into consideration, from extracting raw materials, over production, distribution, use, re-cycling, maintenance and final deposition. All transports are included as well. An LCA should include potential health effects, potential effects on ecosystem and use of natural resources. According to ISO-standards, the LCA is divided into 4 steps:

- Goal and scope
- Inventory
- Environmental effects
- Interpretation of results

An important part of the first part of the study is to define the functional unit. The functional unit is a description of the function the product or service fulfils. It is not “a laundry machine” but “washing two kilos of laundry once a week during one year”. It is also important to set the limits of the study; e.g. the limit between the technical system and nature and the limit between this technical system and other technical systems.

The first results of the LCA can be presented after the second step. It consists of huge amounts of data on different emissions, but it does not say much about the environmental influence. To make the results more comprehensible, an environmental effect evaluation is made. The emissions' contributions to different effect categories (such as Global Warming, acidification, eutrophication and so on) are calculated.

LCA focuses on a product, or rather a function and the potential environmental effect that is calculated is a non-site-specific possible influence.

LCA is commonly used by companies and industries when communicating environmental data, designing and developing products, forming strategies and deciding on purchases. An advantage is that the method is well known and accepted and there is an international standard.

To carry out an entire LCA is very time and data demanding and lack of data is a common problem. The result is also highly correlated to the limits of the studied system. There is a risk that the limits are chosen so that the wanted results are achieved. Therefore it is also difficult to make comparisons between different LCA- studies.

To carry out an entire LCA on concrete repair might be too data demanding, but the “cradle to grave” thinking should applied, and parts of the methods could be suitable.

2.1.3 Environmental risk inventory

A general Environmental Risk Analysis gives answers to the following questions:

Which undesired events can lead to environmental consequences?
How often can they occur?
Which emissions would be the result?

The purpose of the environmental risk analyses described here is to give complementary information to the overall picture given in the LCA. An environmental risk inventory, as the term is referred to here, shows which potentially environmentally hazardous emissions would be a cause of undesired events and how probable they are to occur. In other words: How much is released, what is released, and how often? As a result it is also shown what causes the release. The knowledge of this may be used to minimize the environmental effect.

The term “Environmental Risk Inventory” (ERI) is used rather than environmental risk analysis. To use the term environmental risk analysis, the consequences should be included, something which has not been done here. For example, what would be the effect on the environment of releasing 1 kg of sulfur dioxide? Other projects deal with methods of valuing different types of emissions.

An optional term would be “risk of emission”. This is because the method is aiming at identification and quantification of emissions. Local environmental influence may be discussed.

The first step is to settle the extent of the study. What will be included in the analysis, where will the boundaries be and what will not be included? According to that, an image is created of the studied object or process.

The next step is to decide on a principle for carrying out the study. A systematic way of doing this is necessary so that nothing important is left out. The events and combinations of events (explosions, fires so on) leading up to environmentally hazardous substances being set free are identified. These scenarios are given probabilities, and are then further treated. What amount of the substances will be released? Which secondary effects might occur? The remaining thing to do is the summing-up, where the annual probabilities are multiplied by the amount released by each event, resulting in an annual average release. The released substances are then summed up in a table that is the outcome of the study.

The data found in an ERI does not include all the environmental effects of a process or a method, it only shows the effects of undesired events that may occur during the life cycle. As said earlier, it is complementary information to an LCA.

2.1.4 Environmental indicators or headline indicators

Environmental indicators are a way of presenting environmental data, and can be used by companies as well as countries, depending on the level of the data. For a company it can also be used to measure environmental performance and a tool to measure improvements.

There is no established, uniform definition of “environmental indicators”. The definition depends on the purpose of the indicators and the target group. One definition is:

“Environmental headline indicators usually express the relation between two quantities and may refer to e.g. energy consumption or air emission in correlation to volume of production, economic turnover, square meter, year or some other unit that is informative and relevant.” Indicators could for example describe:

- Energy consumption
- Material use
- Water use
- Release of gases with global warming potential
- Release of substances that harm the ozone layer
- Release of toxic substances
- Release of acidifying substances

3. Evaluation of concrete repair process

In this project the focus is on the effect of the repair on the ecology but other factors such as health of the workers during application (see also REHABCON Manual, ANNEX P) and effects on third party are also considered. The reason for this is that some repair methods would produce pollutants and noise making them unsuitable for use in some environments, like residential areas. Also indoor environment is considered in this study. Even if most concrete repair is executed in outdoor environment there may be

some cases where indoor environment should be considered, i.e. repair of floors. Thus the evaluation is made in three steps:

1. Evaluation of ecology (external environment)
2. Evaluation of indoor environment
3. Evaluation of health and safety

In the literature methods and models have been suggested for environmental evaluation of new structures, examples are work done by A. Sarja in Finland, and The Swedish "Byggsektorns Kretsloppsråd" (Swedish Building Centre: Building products Declaration) using the life cycle perspective.

These methods are used as a base and with some adaptation they can be applicable to the concrete repair process. In the repair process the choice is not as extensive as it is for a new structure. For example the materials, design and heating system are already chosen, meaning that many parameters influencing the total ecology of the structure are already fixed and can not be changed. Thus, some parts of the evaluating systems for new structures can be excluded or at least simplified in the repair case.

The whole life cycle of the repair process is shown in fig. 1.

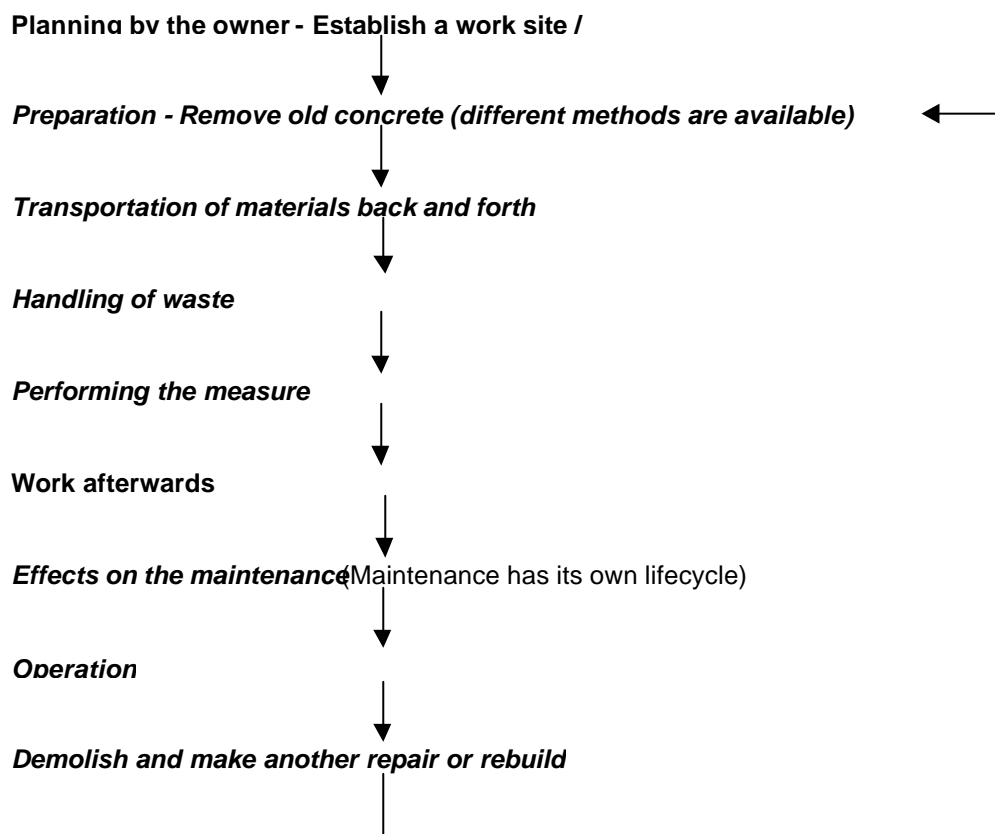

Figure 1. Life cycle of concrete repair

All execution activities and their effect on health and ecology and treated in the evaluation part 2.3.3, Evaluation of execution of repair and upgrading work on the performance of the repaired structure. The following evaluation of ecology focus on the repair material which is evaluated in the life cycle phases of the specific material, meaning that the life cycle

steps are not exactly the same as the steps described in fig. 1. In the ecology evaluation (fig 2) the activities (life cycle steps) described in figure 1 are treated as follows:

Complete Life Cycle Fig 1	Treated in material life cycle step Fig 2
Planning by owner:	Treated I part 2.3.3 (Execution)
Preparation:	Treated I part 2.3.3 (Execution)
Transportation:	Ecology: Distribution
Handling on waste	Ecology: Residual material / Waste
Performing the measure:	Ecology: Constituent materials, Production, Execution
Work afterwards:	Treated in part 2.2.3 (Execution)
Maintenance:	Ecology: Service life
Operation:	Ecology: Service life
Demolish:	Ecology: Demolition

Thus, in the evaluation described here the following steps are treated:

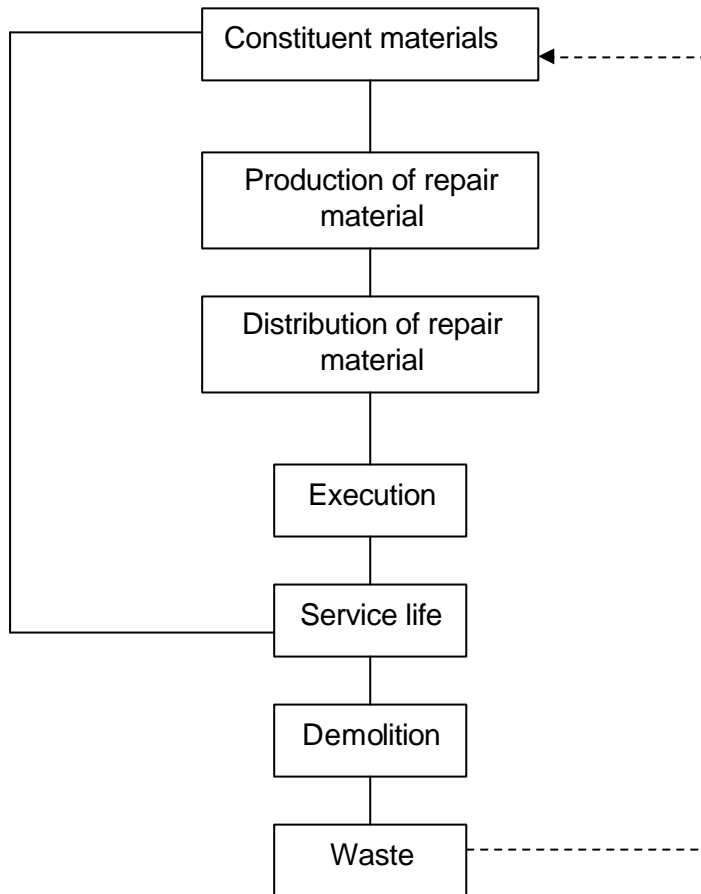

Fig 2: Life cycle steps in the ecology and health evaluation

3.1 Evaluation of concrete repair – ecology

A number of indicators are chosen for evaluation or possibly calculation of the environmental effect. For the ecological evaluation the effects to be considered are:

- Consumption of non-renewable raw materials
- Consumption of non-renewable energy
- Emissions to air including CO₂, CO, SO₂, NO_x, dust
- Emissions to soil and water
- Effect on ground

Summary Table for External Environment. Parameters considered in the ecology evaluation of a repair method or activity

Effect on Ecology Life Cycle Phase	Energy	Raw Materials	Emissions into water and air	Effect on ground
<i>Constituent materials</i>				
<i>Production</i>				
<i>Distribution</i>				
<i>Execution</i>				
<i>Service life</i>				
<i>Demolition</i>				
<i>Residual material / Waste</i>				

It can be stated again that a lot of information needed here is still missing. Therefore one has to accept that some part of the table will remain empty. However it's often useful to make an approximate assumption making it possible to compare two or more repair methods with each other.

3.1.1 Life cycle phases

The phases in the repair life cycle is the base for the evaluation.

Constituent materials

Materials for concrete production have been based on national and usually local raw materials. The main raw material is lime stone and aggregate. The same type of materials is used for the repair of concrete structures. During the last century, the production of polymer based products from refined oil has become possible and new polymer based products and additives have entered the market.

The building sector has been recycling materials for a long time and this has been increasing recently due to limited raw material resources.

Production of repair materials

The most important parameters are the use of energy, emissions into air and water and the influence on ground.

Some of the material input into the production process can be recycled, i.e. water, materials for heating etc.

Distribution of repair materials

The effect on ecology from transport and storing activities depend on the location of the production facilities and which transport system is used. Different kinds of package materials for storing and distribution are also included in the transport phase.

Execution phase

Emissions into air, water and soil during concrete repair execution have to be considered as well as the influence on ground. Materials needed for the execution have to be treated here as well as recycled materials used in the application and not considered in "Constituent materials".

Service life

The main part of a buildings influence on ecology occurs during the service life. Therefore this part is very important when comparing design and materials for a new structure. In the repair process the situation is somewhat different: the design and material is already chosen, giving a certain effect on ecology. Repair means that a damaged structure is brought back to its original performance. Thus in most cases of repair, the effect on ecology during the service life is more or less the same as it was before the repair and in addition the possibility to choose a “better” alternative is very small. However there exist some very special methods, i.e. cathodic protection, that consumes energy during it's entire life time, which of course has to be considered here.

Despite of this, the service life of the repair is important – the longer the service life, the lower impact calculated as impact per “service year”.

Demolition

When the service life of the repair or complete structure is finished, the demolition process need some materials, energy etc. This information should be declared under “Demolition”. Some materials need extra precautionary measures to prevent emission of toxic substances.

Waste

Waste is defined as left over material produced during repair, maintenance of the repair and after finished service life. It could be material that goes to recycling in the life cycle or it can be material going to destruction or disposal.

Waste- and package material can be reused, recycled or go into energy recycling.

When material is disposed it mainly affects water and soil. The leakage aspects have to be considered here.

3.1.2 Effect on ecology

Environmental parameters that have to be considered are the energy consumption, raw material consumption, emissions to water and air and effect on ground.

Energy

The input of energy into the different steps in the life cycle should be considered, as well as information on output of energy from recycled material etc. The types of energy that can be used are

Electricity

Fossil fuels such as oil products, coal and gas

Biomass fuels such as wood and straw

Raw materials and consumption

Raw materials used in the different phases of the life cycle can be divided into “renewable” and “non-renewable”. There is no generally accepted definition on “renewable” but the most common definition is raw materials grown and developed by photosynthesis .

Emissions into water and air

Emissions from different phases in the repair life cycle influence on the ecology. As an example oxygen consuming substances or toxic substances can affect the water.

As examples on emissions into the air, carbon dioxide (CO₂), Sulphur oxides (SO_x), Nitrogen oxides (NO_x) and ozone affecting substances can be mentioned. These

substances could cause global warming, acid pollution and nutrification of seas, lakes and rivers.

Emissions into the indoor air are treated separately in “Indoor environment”.

Effect on the ground

The ground is mainly affected by extracting of raw materials and deposition of waste. Examples are mines, gravel pits etc. The risk of leakage of substances from waste deposits are also included here.

3.1.3 Declaration principles

As a recommendation based on the Swedish Building Products Declarations, the manufacturer/supplier should declare substances in a building material with the following limits:

All substances exceeding 2 percentage weight

All hazardous, corrosive, irritating, allergenic, cancerogenic (symbol X), mutagenic (category 3) and toxic to reproduction (category 3) exceeding 0,1 percentage weight

All substances classified as dangerous for the environment (symbol N) exceeding 1,0 percentage weight.

This is one example, until a European standard exists, the limits can of course vary between countries.

A specific repair material in the repair process is declared in one declaration, thus the total impact on ecology of materials in a repair process is the “summary” of several declarations.

The target is that the input data should be quantitative, however at the time a lot of data are still missing. Until more data are available qualitative data has to be accepted.

There are today several ongoing projects dealing with collecting and processing of available data so that it can be used as input in life cycle assessments and other ecology evaluation processes.

As an example a LCI/LCA project managed by the Cement Industry could be mentioned. One outcome from this project has been an environmental computer program called “EcoConcrete” for providing LCA information on concrete structures. Access to the EcoConcrete program is limited to people who passed a special training course.

Another project called “Eco-Service is sponsored by EC under Framework program 5 and covers research on the construction industry in relation to environmental sustainability. Within the project is an objective to create a baseline for the environmental impact from the production and use of concrete products in a life cycle. It is noted that information is needed in the areas of “Assessment of the impact from chemical additives” and “Possible leaching of harmful substances from concrete with residual products”.

Repair products to be placed in contact with drinking water need to meet specific requirements. There is a project running within the organization of European Commission (CEN/TC 104) with the goal to outline these requirements. A draft positive list of approved constituents of products for contact with drinking water is at the moment discussed but not yet agreed.

When it comes to concrete admixtures EFCA (European Federation of Concrete Admixtures Association) have published a Eco-profile for plasticizers and super-plasticizers. The Eco-profiles include quantitative data for raw materials, emissions to air,

emissions to water, solid waste and total energy per kg admixture. These eco-profiles are derived from primary data supplied by EFCA and its member organizations and verified by an independent consultancy from The Netherlands.

Information for data and the assessment procedure on dangerous chemicals are published by the European Chemicals Bureau (ECB)

3.1.4 Content of ecology declaration

The figure given on each item refers to a box in the summary table, see 7.6

0 Introduction

0.1 Repair activity

0.11 Declare materials used in the repair activity

0.2 Method

Short description of method

0.3 Company information

0.31 Supplier / Contractor
Company, address, etc.

0.32 Environmental policy
Yes/No. Supplier and Contractor

0.33 Environmental Management System
Yes/No. Supplier and Contractor. Type of system. Certified by third party.
Who, registration no.

0.4 Product Information

Declaration of contents

0.41 Classification
Declare if the material is classified as harmful for health and/or environment

0.42 Safety Data Sheet
Yes/No/n.a Declare if Safety Data Sheet (91/155/EC) is available. Date of issue.

1 Materials

1.1 Raw materials/input goods

1.1A Report the type of energy used for the production of the material used in the specific repair activity.

- 1.1B Report the raw materials (renewable and non-renewable) extracted and used for the production of the material used in the specific repair activity.
- 1.1C/D Report the emissions to water and air produced at extraction and refinement of the material used for the specific repair activity.
- 1.1E Report if the extraction / refinement of material affects the ground and if harmful waste material is produced and if so, how it is handled.
- 1.2 Recovered material**
- 1.2A Report the type of energy used for the recovery process.
- 1.2B Report recovered material, if possible give details on amount of material used.
- 1.2C/D Report positive/negative effect on water/air.
- 1.2E Report positive/negative effect on ground.
- 1.3 Origin of material**
- 1.3.1 Record country and city where the material was produced.
- 2 Production of repair material**
- 2.1 Production process**
- 2.1A Report the type of energy used for production of the material for the specific repair activity.
- 2.1C/D Report the emissions to water and air at the production of the material for the specific repair activity.
- 2.1E Report waste products from the production of the material for the specific repair activity and report if they are recovered or disposed. Declare if harmful waste material is produced and if so, how it is taken care of.
- 3 Distribution of repair material**
- 3.1 Place of production**
Record where the material is produced.

3.2 Transport

Report common methods of transport and distribution, and the approximate percentage between them.

3.3 Distribution

Report if the material is distributed via agent/warehouse or direct to user. Report special deliveries, i.e. bulk deliveries.

3.4 Packing

Declare material used in wrapping, and declare if the packing is turnable. If different kind of wrappings are used, declare distribution.

4 Execution phase

4.1 Execution

4.1A Report the need of equipment.

4.1B Report the need of expendable material.

4.1C/D Report if there are emissions to air, water or soil during execution.

4.1E Report if the material can affect the ground during storing and execution. Report if dangerous waste material is produced during the execution process and if so, how it is taken care of.

5 Usage phase

5.1 Operation

5.1A Report the type of energy used during operation of the repair.

5.1B Report those material or equipment that are needed to maintain performance during operation of the repair.

5.1C/D Report if operation of the repair can cause emissions into air, water or soil .

5.2 Maintenance

5.2B Report those material or equipment that are needed to maintain the performance of the repair.

5.2 C/D Declare if maintenance can cause emissions into air, water or soil

5.3 Life time

Expected lifetime at normal usage.

6 Demolition

6.1 Dismantling

Declare how the material can be dismantled to facilitate reuse or recycling. Declare if the repair need special measures to avoid effect on health and environment during dismantling.

7 Waste products

Waste includes packaging materials, waste products from application (spill) and demolition. State whether the supplier has a system for recovering packaging materials.

- 7.1 Reuse**
State whether the repair material and packaging can be reused.
- 7.2 Material recycling**
State whether the repair material and packaging can be recycled. At recycling the material is treated and then used for production of new raw material.
- 7.3 Extraction of energy**
State whether the waste material can be used for extraction of energy (combustion).
- 7.3D Report if the combustion produces emissions into air, water or soil.
- 7.3E Report if slag products are produced and if they should be handled as harmful waste material.
- 7.4 Tipping**
7.4 C/D/E State to what extent leaching and emissions can occur.
- 7.5 Harmful waste materials**
State whether the repair material need to be handled in accordance with the regulations on harmful substances.

7.6 Summary table for external environment

No.	LIFE CYCLE PHASE	Type of energy	Raw materials	Emission to water	Emission to air	Effect on ground
		A	B	C	D	E
1.	CONSTITUENT MATERIALS					
1.1	- Raw materials					
1.2	- Recovered material					
1.3	- Origin of raw material					
2.	PRODUCTION OF RAW MATERIAL					
2.1	-Production process					
3.	DISTRIBUTION OF FINISHED PRODUCT					
3.1	-Production area / country					
3.2	-Transport method					
3.3	-Distribution type					
3.4	-Packaging					
4.	EXECUTION PHASE					
4.1	-Repair execution					
4.2	-Product adaptation					
5.	USAGE PHASE					
5.1	-Operation					
5.2	-Maintenance					
5.3	-Service life					
6.	DEMOLITION					
6.1	-Dismantling					
7.	WASTE PRODUCTS					
7.1	-Reuse					
7.2	-Recycling					
7.3	-Energy production					
7.4	-Tipping					
7.5	-Dangerous waste material					

3.2 Evaluation of concrete repair – indoor environment

Many people are reporting health problems related to the indoor environment. The symptoms are often asthma and allergies. There is great uncertainty today about what is causing the symptoms, and research activities are going on trying to find the relations between ill-health and the choice of chosen building material, design and building method. These relations seem to be very complex. The information we have today indicate that the determining factor for the quality of the structure is how the materials have been built in to the structure rather than the individual properties of a specific material.

When choosing material for repair, a material without emissions of any harmful or irritating substances into the indoor atmosphere should be used. The material must also have good resistance to the various stresses to which they are exposed – not least moisture. This is of course valid for materials in new as well as repaired structures.

3.2.1 Indoor environmental parameters

As the processes leading to ill-health from indoor environment are still not fully understood this chapter should be considered as a summary of factors to be taken into consideration by the various members involved in the concrete repair process.

Even here there is a big lack of facts and data meaning that this process should be seen more as a checklist than a complete evaluation tool. It can also be used as a tool for comparing the impact of different repair methods or repair materials on the indoor environment. This evaluation of indoor environment is only relevant when the repair activity takes place in a indoor structure. In case of an outdoor structure this part can be left out.

Content of health effecting substances

To avoid health problems in indoor structures, the owner must be able to choose materials that minimize the risk of allergy. In lack of complete information concerning relations between health and building materials, materials with low emissions of substances suspected to give health problems are preferable.

Local regulations should be checked and followed.

Self emissions and odour

Information regarding self emissions help to identify which substances are emitted by a specific building material or building product. The information is subject to considerable uncertainty since the course of events involved is often dynamic and changes according to different conditions in the completed building. Standardized measuring methods exist in some countries but generally there is a need for development. It will be possible to use emission specifications for reporting the indoor environment. Emissions that decrease with time should be reported in such a way that special measures can be taken in order to minimize the effect on the indoor environment. Discernible odour should also be recorded.

The repair process

Building products can be sensitive to moisture, temperature, vibrations, shock and other influences. Information on how these factors affect the indoor environment should be stated in order to avoid negative effects during storage and building.

In cases where ill-health has been reported it has been found that specific materials have been used in combination with high level of moist during the building process. On the building site, repair materials should therefore be well covered and protected from damage and moisture. If relevant, materials should be well aired and dried before being assembled and they should be protected from rain.

Surrounding materials

The emissions from the structure cannot solely be related to the self emissions of single materials. The substances emitted depend rather upon the effect of the different materials on each other, especially in combination with moisture, i.e. so-called secondary emission. It is therefore important that suppliers state which surrounding materials are recommended and that those who design and build know which conditions are required in order to build correctly from an environmental point of view.

Operation and maintenance

Many surfacing materials and installations require maintenance for their function to be sustained throughout their operational life. Some building materials require chemicals for their maintenance that can cause allergic reactions.

Sound level

Noise is a contributory factor to people poor health. It is therefore important to state the sound level of an installation. This applies to both high- and low frequency sounds. By low frequency sounds, sounds below 100 Hz are concerned.

Electrical and magnetic fields

Electrical and magnetic fields are suspected of having a negative effect on certain peoples health.

3.2.2 Content of indoor declaration

Declaration for indoor environment is only drawn up for activities or products that affect indoor environment. The figure given on each item refers to a box in the summary table, see 8.8.

8.1 Harmful substances

State the substances classified as harmful according to regulations. The reporting should also cover substances which can cause emissions or contact allergy. Quantities, see "External environment", 3.1.3.

8.2 Self emissions

Declare the self emission of the material (in emission factor $\mu\text{g}/\text{m}^2\text{h}$) reported under 8.1. State also the odour, the intensity and decrease with time. Report test method used, which should preferable be a standardised methods for self emissions.

8.3 The repair process

State all storage and work requirements to avoid negative effects on the indoor atmosphere. References may be made to work directions and assembly instructions.

8.4 Surrounding materials

State requirements and recommendations for the characteristics of surrounding materials, such as composition, temperature, pH, RH etc. if these affect the indoor atmosphere.

8.5 Basic data for suggested stipulations as per 8.4 for surrounding materials

State what the recommendations in 8.4 are based upon, i.e. experience, tested method or emission measurements. State whether measurements have been carried out in accordance with a particular standard or other established method. A development of uniform trade methods is expected.

8.6 Operation and maintenance

State which product or product types are required for care and operation of the repair system or product. State also other factors at operation and maintenance that affect indoor environment, i.e. cause odour.

8.7 Sound level

Measuring results relating to installations dB(A) and dB(C). State test and any trade standard.

8.8 Electric and magnetic fields

Report values for installations and state test method and any trade standard.

Summary table for indoor environment

8.1	Harmful substances	
8.2	Self emissions	
8.3	The repair process	
8.4	Surrounding materials	
8.5	Basic data for recommended conditions for surrounding material	
8.6	Operation and maintenance	
8.7	Sound level	
8.8	Electric and magnetic fields	

3.3 Evaluation of concrete repair – health and safety

Questions related to health and safety for the workers during handling of the repair materials are regulated in the legislation. The work on classification and labeling on chemical products is done on an international basis. This work has a high priority in Europe and the legislation within EC is in common since a couple of years ago.

Manufacturers, importers and others who place a product on the market for professional use a product shall provide information on the properties of the product from the viewpoints of risk and safety.

Safety data sheets need not be provided when products are marketed, sold or supplied in consumer packaging in retail trade to the general public. Safety data sheets for such products shall on the other hand be made available if requested by a professional user.

3.3.1 Health and safety parameters

All marketed substances and preparations placed on the European market must be classified and labeled in accordance with Directive 67/548/EEC (substances) and 1999/45/EC (preparations). The evaluation result in classification of the chemical product concerning physical-chemical properties, health and environmental effects. The information is communicated on the label and in the 16 point Safety Data Sheet (91/155/EC). Therefore Classification and Labeling is a useful tool for risk management of chemical products.

For evaluating the health and safety parts, data given in the 16 point Safety Data Sheet (point 1, 2, 3, 10, 11 and 15) can be used.

1. Identification of the substance/preparation and company

The trade name or designation used in the labeling shall be given. For substances, the chemical name used in the labeling shall also be given. The name of the manufacturer, importer or other person placing the product on the market shall be given. A full address and telephone number shall also be given.

2. Composition/information on ingredients

The information given should enable the recipient to identify readily the risks attaching to the substance or preparation.

In the case of a preparation:

- (a) it is not necessary to give the full composition (nature of the ingredients and their concentration);
- (b) however, the following substances shall be indicated, together with their concentration or concentration range, if they are present in concentrations equal to or greater than those laid down in Article 3 (6) (a) of Directive 88/379/EEC (unless a lower limit is considered more appropriate):
 - substances presenting a health hazard within the meaning of Directive 67/548/EEC, and
 - at least substances subject to recognized exposure limit values pursuant to Community provisions but which are not covered by the above Directive;
- (c) the classification (either from Article 5 (2) of or Annex I to Directive 67/548/EEC) of the above substances shall be given in the form of the symbols and R phrases which are assigned in accordance with their health hazards;
- (d) if, in accordance with the provisions of Article 7 (1) of Directive 88/379/EEC, the identity of certain substances is to be kept confidential, their chemical nature shall be described in order to ensure safe handling. The name used must be the same as that which derives from the above procedure.

3. Hazards identification

Indicate clearly and briefly the most important hazards the substance or preparation presents, in particular the critical hazards to man and the environment.

Describe the most important adverse human health effects and symptoms relating to the uses and possible misuses of the substance or preparation that can reasonably be foreseen.

The information should be compatible with that shown on the product label but need not repeat it.

10. Stability and reactivity

State the stability of the substance or preparation and the possibility of hazardous reactions occurring under certain conditions.

Conditions to avoid:

List those conditions such as temperature, pressure, light, shock, etc., which may cause a dangerous reaction and if possible give a brief description.

Materials to avoid:

List materials such as water, air, acids, bases, oxidizing agents or any other specific substance which may cause a dangerous reaction and if possible give a brief description.

Hazardous decomposition products:

List hazardous materials produced in dangerous amounts upon decomposition.

N.B. Address specifically:

- the need for and the presence of stabilizers,
- the possibility of a hazardous exothermic reaction,
- safety significance, if any, of a change in physical appearance of the substance or preparation,
- hazardous decomposition products, if any, formed upon contact with water,
- possibility of degradation to unstable products.

11. Toxicological information

This section deals with the need for a concise but complete and comprehensible description of the various toxicological (health) effects which can arise if the user comes into contact with the substance or preparation.

Include dangerous-to-health effects from exposure to the substance or preparation, based on both experiences and conclusions from scientific experiments. Include information on the different routes of exposure (inhalation, ingestion, skin and eye contact), and describe the symptoms related to the physical, chemical and toxicological characteristics.

Include known delayed and immediate effects and also chronic effects from short- and long-term exposure: for example sensitization, carcinogenicity, mutagenicity and reproductive toxicity including teratogenicity, and narcosis.

Taking account of the information already provided under point 2,

'Composition/information on ingredients', it may be necessary to make reference to specific health effects of certain components in preparations.

15. Regulatory information

Give the information on the label according to the Directives relating to the classification, packaging and labeling of dangerous substances and preparations.

If the substance or preparation covered by the safety data sheet is the subject of specific provisions in relation to protection of man or the environment at Community level (e. g. restrictions on marketing and use, limit values for exposure at the place of work) these provisions should, as far as is possible, be stated. The attention of recipients should also be drawn to the existence of national laws that implement these provisions.

It is also recommended that the data sheet should remind recipients to refer to any other national measures that may be relevant.

The above mentioned paragraphs are taken from the EC Directive 91/155/EC valid December 2003. It is always necessary to check the latest published Directive for the evaluation process.

The above mentioned points contain the most important information for the evaluation of health and safety risks during the execution phase. This is essential information in the evaluation process at a state where two or more concrete repair methods are compared before the final choice is made. Other information in the Safety Data Sheet deals with protective measures and recommendations for handling. Of course this information is very important later in the process, for all people involved in the handling of the product. In point 12 in the Safety Data Sheet ecological information is given. As this information is treated in a separate evaluation it is not treated here.

4 Example

The repair to be studied and exemplified is: Patch Repair

Damage:

Method: Removing of damaged concrete and application of new repair mortar using cement based mortar mixed at jobsite. In this case the indoor environment of the structure will not be effected meaning that only external environment and health and safety are evaluated.

4.1 Evaluation of concrete repair – ecology

4.1.1 Evaluation of repair mortar

Name of product: "Polymer modified cement based repair mortar"

Name of Manufacturer/Supplier: "Supplier"

Environmental policy/Certification/Registration: Yes/ISO 14000/No xyz.

Product information:

Product: Cement based one component repair mortar in powder

Constituent material in structure: 100% concrete

Safety data sheet: Yes

Classification: Xi Irritating

No.	LIFE CYCLE PHASE	Type of energy	Raw materials	Emission to water	Emission to air	Effect on ground
		A	B	C	D	E
1.	CONSTITUENT MATERIALS					
1.1	- Raw materials					
	Standard Portland cement	fossil and electricity	Limestone and sand		CO ₂ , NO _x , SO ₂	limestone open-cast mine
	Aggregate, crushed and natural	Electricity and fuel for transport	Rock, nature			open-cast mining", gravel pit
	Admixtures					
	Acrylic polymer					
1.2	- Recovered material	Energy in cement production				
1.3	- Origin of raw material	Europe				
2.	PRODUCTION OF RAW MATERIAL					
2.1	-Production process	Electricity				
3.	DISTRIBUTION OF FINISHED PRODUCT					
3.1	-Production area / country	Sweden				
3.2	-Transport method	Truck				
3.3	-Distribution type	Truck				
3.4	-Packaging	Paper bag				
4.	EXECUTION PHASE					
4.1	-Repair execution	The mortar is usually mixed with electrical hand mixer and applied by hand at jobsite.				
4.2	-Product adaptation	Small quantities are mixed during proceeding of work. No mixed mortar left.				
5.	USAGE PHASE					
5.1	-Operation	Does not effect operation of structure				
5.2	-Maintenance	No need				
5.3	-Service life	Depends on environment, specific structure etc.				
6.	DEMOLITION					
6.1	-Dismantling	Normally no specific need.				
7.	WASTE PRODUCTS					
7.1	-Reuse	n.a.				
7.2	-Recycling	Yes, both material and packaging				
7.3	-Energy production	Packaging: yes. Material: no				
7.4	-Tipping	Inert material: no restrictions				
7.5	-Dangerous waste material	No				

4.2 Evaluation of concrete repair – health and safety

4.2.1 Evaluation of repair mortar – health and safety

1. Identification of the product and of the company

Product name: "Polymer modified cement based repair mortar"

Manufacturer/Supplier: "Supplier"

2. Composition/information on ingredients/classification of substances

- a) Cement: 25-50%, Xi (Irritating), R-phrase 41, 37/38. Contains chromium (VI). May produce an allergic reaction.

3. Hazards identification

Xi Irritant

Information on hazards to man and to the environment

37/38 Irritating to respiratory system and skin

41 Risk of serious damage to eyes

Contains chromium (VI). May produce allergic reaction.

10. Stability and reactivity

Materials to avoid due to dangerous reactions.

Hazardous reactions possible with: Acids

Thermal decomposition and hazardous decomposition products: No decomposition if used as prescribed.

11. Toxicological information

Sensitization: Allergic reactions can be observed by sensitive persons.

Experience on humans:

When skin contact: May cause irritation.

When eyes contact: Irritation

When inhalation: Irritation

When swallowed: Small amounts may cause considerable health disorders.

15. Regulatory information

Labeling according to EEC Directive

The product is classified and labeled in accordance with EC directives/the relevant national laws.

Danger symbols: Xi Irritant

R phrases:

37/38 Irritating to respiratory system and skin

41 Risk of serious damage to eyes

Contains chromium (VI). May produce an allergic reaction.

S phrases

26 In case of contact with eyes, rinse immediately with plenty of water and seek medical advice

39 Wear eye/face protection

5 References

Sarja,A.: Integrated life cycle design of structures. Technicalresearch Centre of Finland. Spon Press, New York,2002.

Swedpower: M. Ellfors, Methods for evaluating environmental impact. 2002-11-19

EFCA Environmental Declarations: EFCA doc.124ETG eu November 2002

EFCA Environmental Declarations: EFCA doc.125ETG eu November 2002

Swedish Building Centre: Building Product Declarations. Part of the building sector's responsibility for building products. A publication from the Ecocycle Council for the Building Sector. Printed by AB Svensk Tryck AB, Stockholm 1998.

European Chemicals Bureau (ECB): <http://ecb.jrc.it/>

European Legislation: <http://europa.eu.int/eur-lex/en/index.html>

ANNEX 6

EVALUATION WITH REGARD TO ECONOMY APPLICATION EXAMPLE

Abstract

This ANNEX is related to paragraph 6 in the Main Document.

An example is given in order to illuminate the use of the evaluation procedure described in the Manual.

Three alternative repair options are evaluated. The required service life of all options is 50 years.

Introduction

In this appendix an example is presented in order to illuminate the application of the equations given in REHABCON Manual, paragraph 6.6.3. It should be noted that the assumptions and figures are made for the sake of simplicity and should not be interpreted as facts.

In this example three repair options, $RO_1 - RO_3$, are compared. It is required that the structure subjected to repair should have 50 years service life after the repair.

1 Repair options

Repair option RO_1

The repair option RO_1 can protect the structure during 25 years, and should be repeated every 25 years.

Repair option RO_2

The repair option RO_2 can protect the structure during the remaining 50 years of the service life of the structure.

Repair option RO_3

The repair option RO_3 is postponement of repair for 5 years. After 5 years the structure is repaired. During the first 5 years the special inspection and maintenance measures will be taken, which increase the inspection and maintenance costs.

2 Assumptions

The net cost of repair can be expressed in similar way as equation 6.6.1 in paragraph 6.6.3. The cost and return entries are assumed to be: Application costs (C_A), Inspection costs (C_I), Maintenance costs (C_M), User costs (C_U), Other costs (C_O). Other costs and returns such as failure costs, value increase and residual value are disregarded. The total present value of the repair cost may be expressed as follows:

$$C_{NR} = C_A + C_I + C_M + C_U + C_O \quad (\text{A6.5.2})$$

Application costs include all types of costs until the repair work is completed, such as cost of planning, design, execution, material and safety regulations. The application may also induce capital cost and annual repayment of the loans. They are disregarded in this example. These types of costs can be taken into account in the similar way as the inspection and maintenance cost.

Costs of user may be caused by traffic stops, in the case of bridges, or inconveniences of the tenants, etc.

Other costs include the costs related to the removal of the repair, dumping and tolls related to the immediate and global environment.

The costs are assumed to be proportional to some basic values, $V_1 - V_3$, which assumed to be characteristic for the repair options.

Assumptions valid for all repair options:

Discount rate	$r = 2\%$
Calculation period	50 years
Application costs, C_A	$1 \cdot V$
Inspection costs, C_I	$0.005 \cdot V$ annually
Maintenance costs, C_M	$0.005 \cdot V$ every third year
Cost of user, C_U	$0.01 \cdot V$
Other costs, C_O	$0.1 \cdot V$

The following specific assumptions are applied:

The repair option RO_3 in which repair will be postponed 5 years the basic cost of the repair system will be V_3 . During the 5 years before repair, inspection and maintenance will be more expensive, for instance 50% more than above.

3 Calculations

Repair option RO_1

This repair system should be applied two times. The costs will be calculated in two steps. Basic value for calculation is V_1 .

Step 1 - Costs related to the first application

$$C_{A1} = 1 \cdot V_1$$

C_{I1} is calculated by means of equation 6.6.5 in paragraph 6.6.3 with following inputs:

$$N = 25$$

$$m = 1$$

$$k = 24$$

$$y_i = 0.005V_1$$

$$C_{I1} = (0.005V_1) \cdot \frac{1 - (1 + 0.02)^{-24}}{0.02} = 0.095V_1$$

C_{M1} is calculated in the same way as above, but with $m = 3$, $k = 8$.

$$C_{M1} = 0.031V_1$$

Cost of user is induced at the present time.

$$C_{U1} = 0.01V_1$$

Other costs will be induced when the repair is being removed. The discount is calculated by means of equation 6.6.2.

$$C_{O1} = \frac{0.1V_1}{(1 + 0.02)^{25}} = 0.061V_1$$

The discounted costs of the repair RO_1 during the first 25 years can be calculated by addition of the costs presented above.

$$C_{R1} = V_1 + 0.095V_1 + 0.031V_1 + 0.01V_1 + 0.061V_1 = 1.20V_1$$

Step 2 - Costs related to the second application 25 year later

C_{R2} can be calculated by discounting C_{R1} 25 years.

$$C_{R2} = \frac{1.20V_1}{(1+0.02)^{25}} = 0.73V_1$$

The total cost for the RO_1 is:

$$C_R = C_{R1} + C_{R2} = 1.20V_1 + 0.73V_2 = 1.93V_1$$

Repair option RO_2

Calculation for this repair option can be performed in the same way as the first part of the RO_1 , but with $N = 50$ years. Only the results are shown here.

$$C_R = V_2 + 0.155V_2 + 0.050V_2 + 0.01V_2 + 0.037V_2 = 1.25V_2$$

Repair option RO_3

This case is calculated in two steps. Step 1 includes inspection and maintenance costs for 5 years before repair. Step 2 includes calculation of the repair costs for 45 years and the result of this step is then discounted 5 years to obtain the present value.

Step 1 - Costs of 5 initial years without repair

It is assumed that the inspection and maintenance costs are 50% higher than usual.

$$C_{I1} = (1.5 \cdot 0.005V_3) \cdot \frac{1 - (1+0.02)^{-4}}{(1+0.02)^1 - 1} = 0.029V_3$$

Maintenance is performed once during 5 years, presumably after 3 years.

$$C_{M1} = (1.5 \cdot 0.005V_3) \cdot \frac{1 - (1+0.02)^{-3}}{(1+0.02)^3 - 1} = 0.007V_3$$

The postponement of the repair will cost:

$$C_{R1} = C_{I1} + C_{M1} = 0.029V_3 + 0.007V_3 = 0.036V_3$$

Step 2 - Costs of repairs

$$C_A = 1 \cdot V_3$$

C_{I2} is calculated by means of equation 6.6.5 with following inputs:

$$N = 45$$

$$m = 1$$

$$k = 44$$

$$C_{I1} = (0.005V_3) \cdot \frac{1 - (1+0.02)^{-44}}{0.02} = 0.145V_3$$

C_{M2} is calculated in the same way as above, but with $m = 3$, $k = 14$.

$$C_{M2} = 0.046V_3$$

Cost of user is induced at the present time.

$$C_{U2} = 0.01V_3$$

Other costs are caused when the repair is being removed. The discount of this is given below:

$$C_{O2} = \frac{0.1V_3}{(1+0.02)^{45}} = 0.041V_3$$

$$C_{R2} = (V_3 + 0.145V_3 + 0.046V_3 + 0.01V_3 + 0.041V_3)/(1+0.02)^5 = 1.12V_3$$

Total cost for the OP_3

$$CR = CR_1 + CR_2 = 0.036V_3 + 1.125V_3 = 1.16V_3$$

Results of the calculations

Total cost of the repair option 1, OP_1 :	<u>$1.93V_1$</u>
Total cost of the repair option 2, OP_2 :	<u>$1.25V_2$</u>
Total cost of the repair option 3, OP_3 :	<u>$1.18V_3$</u>

4 Comments on the calculation example

As mentioned above, the example is concocted to illuminate the application of the mathematical formulas for different repair scenarios. The aim has not been to show the advantage or disadvantage of any option. Nevertheless, the effects of some of the parameters on the outcome of the economical evaluation can be discussed.

The cost entries have been chosen proportional to a given value, and the proportionality factors are the same in all repair options. These assumptions mean that the repair with lowest basic value has the lowest cost entries, for instance if $V_1 < V_2$ each inspection and maintenance actions in RO_1 will be cheaper than those in RO_2 , i.e. the cheaper the repair the cheaper the inspection and the maintenance etc. These assumptions may be valid in some cases, but not in some other cases. As an example may be mentioned that a good quality repair may be more expensive to apply but it demands less inspections and maintenance. Using stainless steel instead of carbon steel may increase the application costs, but might extend the service life and demand less inspections and maintenance.

The need of inspection and maintenance increases with the age of the repaired structure. The inspection and maintenance may be superficially and cheap in the beginning and more detailed and expensive at the end of the service life of the repair. This means that these cost entries are not constant, but increase with time. The costs will be moved to the future, and consequently the discounted cost will be less.

The user costs were also assumed to be proportional to the basic value. The assumption leads to lower user costs for cheaper repair. The assumption can be somewhat correct, if it can be assumed that cheap repair is equivalent to easy and fast repair.

It can also be argued about the way of considering the costs associated with the removal of the repair, dumping and tolls related to the immediate and global environment. A high quality repair containing non-hazardous components may be cheaper to be removed and dumped. Their environmental tolls may be lower and the removed material may have alternative usage. These issues, however, depend upon the type of the structure and varies between countries. Since these types of issues are dependent on the future legislations it is difficult to assume a reliable level for these kinds of cost entries. A material which is allowed to be used today may be forbidden in the future. Many polymer based materials which were allowed to be used 20 years ago are now considered as hazardous materials. Silica fume was hard to get read of some decades ago, but now is a coveted material within the concrete industry.

Two other very important components of the presented example are the discount rate and the length of the calculation period. The latter is highly depended on the models which predict the service life of the repair. The economical analysis will not be reliable if the models fail to predict the service life of the repair accurately. This may in some extent be considered as a risk. Furthermore, the selected repair system may cause another type of damage which is not regarded in the analysis. This can, as well as the former case, be regarded as a risk. These types of risk can be regarded as cost of failure and will be discussed later. The influence of the discount rate will be discussed next.

Figure A.2 shows discounting factor, equation 6.6.2 with $x_{i,j} = 1$, for different discount rates. Figure A.3 shows the discounting factor for periodical costs, equation 6.6.5 with $y_j = 1$ and $m = 1$, for different discount rates. The curves are calculated for cost intervals $m = 1$ and $k = \text{Number of years} - 1$.

As can be observed, the discount rate has great influence on the factors. It is very important to consider this effect when comparing repair systems over a long period of time.

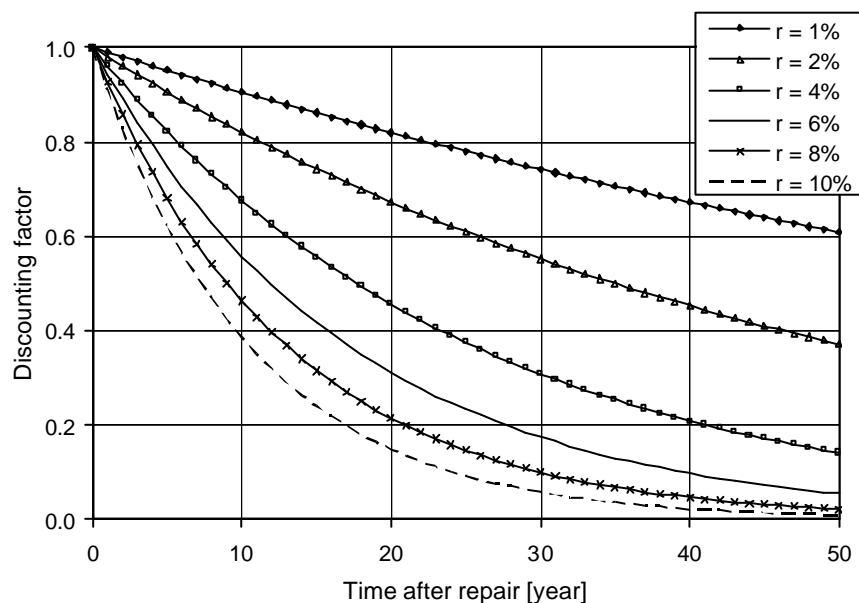

Figure A.2 Discounting factor, i.e. relative present value of a cost entry which occur some years after repair.

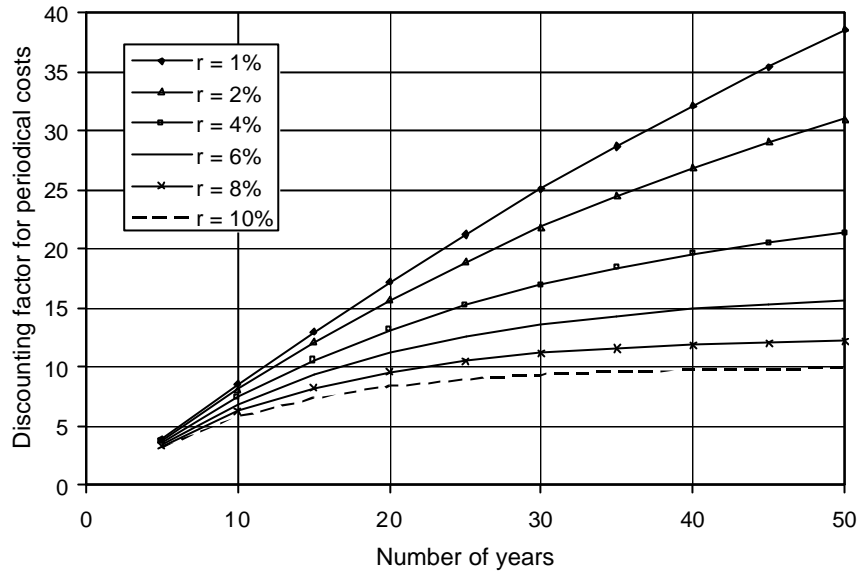

Figure A.3 Discounting factor for constant periodical costs, i.e. relative total present value of a cost entry which occurs each year during a number of years after repair.

The costs of the repair options in the above mentioned example are recalculated for several discount rates and the results are shown in figure A.4. The figure shows the total cost factor versus the discount rate. The total cost factor is the total cost calculated for $V_1 = V_2 = V_3 = 1$. The calculation algorithm is the same as in the example.

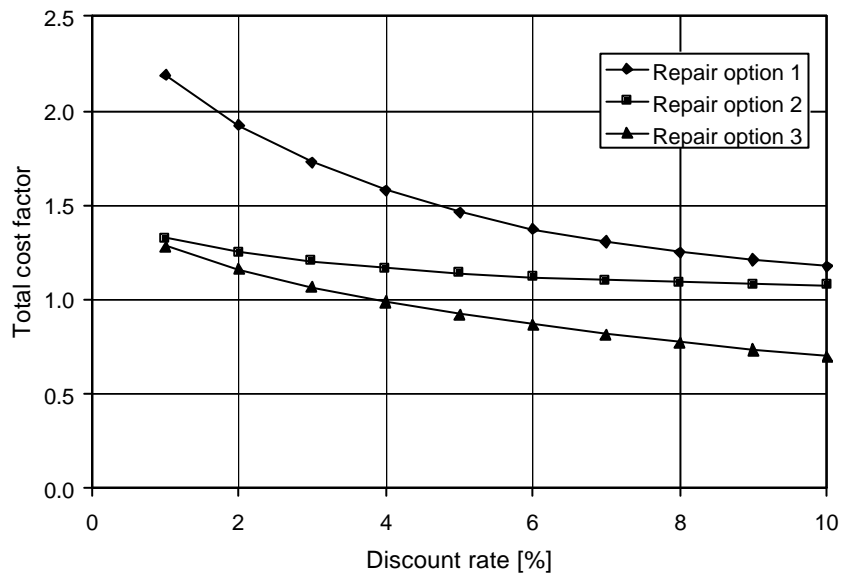

Figure A.4 Discounting factor for periodical costs, i.e. relative total present value of a cost entry which occurs each year during a number of years after repair.

Both repair option 1 and 3 shows great sensitivity to the discount rate. The following conclusions can be made if the assumptions made in the example are valid:

- It is beneficial to repair once and with high quality repair system, because if the repair fails it has to be done twice, or more, which can lead to much higher costs.

ANNEX 6 Evaluation with regard to economy. Application example

- It is beneficial to wait and then use a high quality repair instead of a rapid and non-appropriate repair.
- The results show that the repair failure may have great economical consequences because additional repairs increase the total cost.

The discount rate is not constant and fluctuates. The rate varies between countries and between companies. Some examples can be found in reference [8].

ANNEX 7

CONSIDERATIONS TO NON-TECHNICAL ISSUES (NTI)

Abstract

This ANNEX is related to paragraph 7 in the Main Document.

The Manual focuses on technical questions, such as durability, structural capacity, execution of work. Also questions of less technical content but still with profound technical background are treated, such as impact of repair work on environment, and cost of repair. There are, however, other questions to consider, that are of purely non-technical nature. Such questions are discussed in this ANNEX.

CONTENTS

1	Introduction	4
2	Overview of Non-Technical Issues	5
3	Incorporation of Non-Technical Issues within REHABCON Manual.....	7
4	Description on various non-technical issues	7
4.1	Economic and Financial Evaluation.....	7
4.1.1	Procurement and type of contract	7
4.1.2	Strength of local economy.....	8
4.1.3	Improvement of asset value	8
4.1.4	Whole life costing.....	8
4.1.5	Cost versus benefit to society.....	8
4.1.6	Loss of revenue during the course of repairs or rehabilitation works	9
4.1.7	Indirect economic benefits	9
4.1.8	User cost	9
4.1.9	Public confidence	9
4.2	Social and Cultural Issues	10
4.2.1	Target groups	10
4.2.2	Education and training.....	10
4.2.3	Aesthetics	10
4.2.4	Social perception.....	10
4.2.5	Social alarm.....	10
4.2.6	Reputation.....	11
4.2.7	Media and Press.....	11
4.2.8	Government policies and initiatives	11
4.2.9	Legal issues	11
4.2.10	Health and safety requirements	11
4.2.11	Insurance and future liabilities	12
4.2.12	Working environment.....	12
4.2.13	Repair time	12
4.2.14	Risk and safety	13
4.3	Environmental Issues.....	13
4.3.1	Global Environment	13
4.3.2	Local and site (neighbourhood) issues for the built and rural environment	13
4.3.3	Internal environment within facility.....	14
	Ranking of NTI for specific repair object/repair method.....	15

1 Introduction

Although concrete is a very durable material, it is not maintenance free. The current age of much of the existing infrastructure requires decisions to be made and priorities assigned for repair, maintenance or replacement of these assets.

The financial resources available to governments, local authorities and commercial organisations are not infinite and require difficult decisions to be made in respect of their allocation for repair and maintenance of the existing structures. Clearly these decisions must consider the technical aspects and the physical condition of the structure in question and the way these factors influence the functional performance of the asset, but in many cases they also need to embrace the wider political, environmental and socio-economic issues as well.

Figure 1 illustrates the primary headings under which matters are often broadly grouped. These apply to both the construction phase and to the processes for through-life management of an asset. The Functional factors are often referred to as being technical issues, whereas the other topics concerned with Economic, Socio-cultural and Environmental factors are sometimes referred to collectively as being non-technical issues.

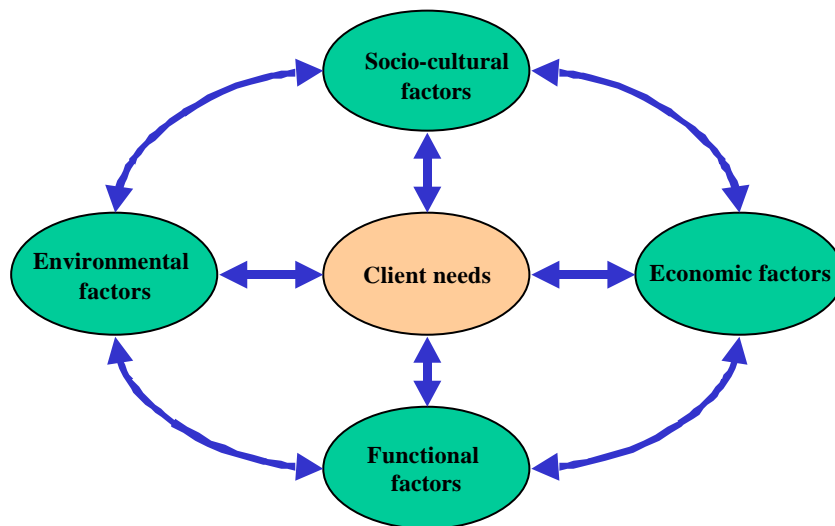

Figure 1. Components of sustainable construction for provision of new assets and facilities, as well as for the management of their through-life performance.

2 Overview of Non-Technical Issues

Table 1 address selected non-technical issues and provides some insight as to where their influence might be in the decision making process, with the relevant points being identified in Figure 2 via the markers A to G.

Primary Classification of Requirement	Non-Technical Issue (NTI)	Stage in Decision Making Process						
		A	B	C	D	E	F	G
Economic and Financial	Procurement and type of contract	X						X
	Strength of local economy	X						
	Improvement of asset values			X				
	Effect on third parties	X					X	
	Whole-life cost		X			X	X	X
	Cost versus benefit to society		X		X	X	X	X
	User cost			X	X	X	X	X
	Public confidence			X			X	
Social and Cultural	Target groups			X	X	X		
	Education and training	X				X		
	Aesthetics			X	X	X	X	
	Social perception			X			X	
	Consultation			X				
	Social alarm	X					X	
	Reputation			X			X	
	Media and press	X		X			X	
	Government policies and initiatives		X					X
	Labour union aspects			X	X	X	X	
	Legal issues			X	X	X	X	
	Health and safety requirements			X				X
	Insurance and future liabilities		X	X			X	
	Working environment			X	X	X	X	
Repair time			X	X	X	X		
Risk and safety	X		X					
Environment	Global environment	X		X	X	X	X	X
	Neighbourhood issues			X	X	X	X	X
	Internal environment		X					X

Table 1. Some aspects of non-technical issues and their interaction in the REHABCON decision making model illustrated in Figure 4.

Figure 4, taken in conjunction with Table 1, illustrates where various non-technical issues might impact on different stages and aspects of the decision making process.

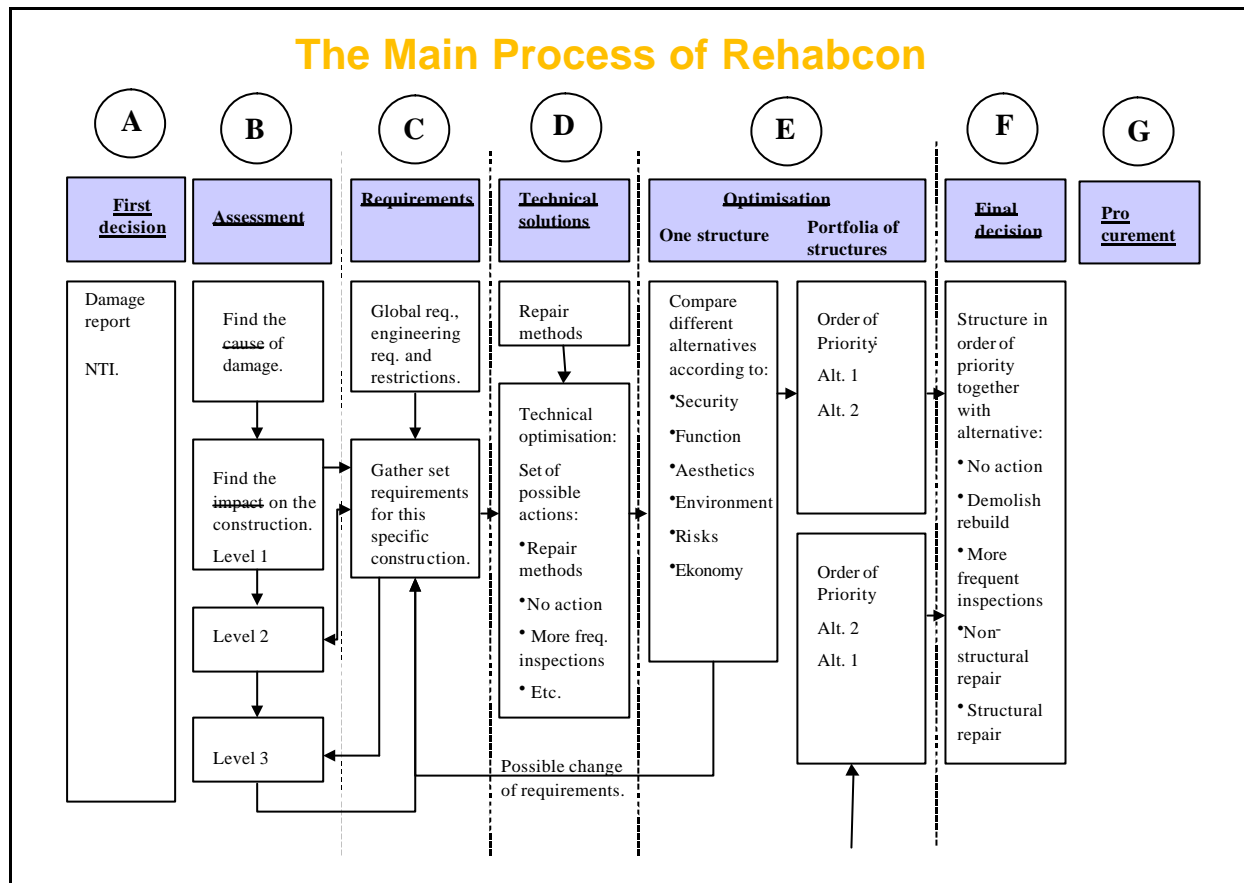

Figure 4. Potential interaction of non-technical issues and the overall decision making model for REHABCON

The non-technical issues relating to the rehabilitation of concrete structures can be broken down into the following six main subject areas. These issues need to be considered for all repair and rehabilitation schemes. However, their influence in different schemes will vary. The subject areas are :

- Ownership (public or private)
- Type of structure (bridge, office building, dam, etc)
- Location (rural, urban, site of special scientific interest, etc)
- Size and geometry of structure
- Importance (eg, listed structure)
- Other

The breakdown given here is for convenience only. Considerable overlap exists between these subject areas. For example, environmental issues will have cost implications, but they may also be part of a political agenda.

The object of compiling this list is to flag up the possible range of non-technical issues that may need to be taken into account in identifying the optimum solution. It is not a comprehensive list and other factors may arise for particular schemes. The list of issues should be drawn up for each specific structure, along with some measure of their importance in the particular context.

Because of the large range of structure types and conditions being covered within the scope of the REHABCON project it is not possible to be prescriptive in how these issues should be considered. For some schemes, non-technical issues will have little influence on the decision-making process. For others, the process will be straight-forward, in that non-technical issues may act as constraints on the potential solutions and may, for example, result in the elimination of particular options. Others have costs associated with them that can be taken into account through an economic evaluation. In all cases engineering judgement will be required.

3 Incorporation of Non-Technical Issues within REHABCON Manual

It is difficult to validate the non-technical issues as they vary from client to client and also from object to object. The non-technical issues must more and more be addressed in the decision processes in the future planning for a repair. As it is difficult to quantify the non-technical issues some type of weighting system can be one method for the decision. In ANNEX A a ranking system of Non-technical Issues for specific repair object/repair method are given.

4 Description on various non-technical issues

4.1 Economic and Financial Evaluation

Economic issues are crucial to decisions on repair and should be considered for each option under review. The weighting of the issues will differ, both in respect of the option and in respect of client needs. It is important to consider future business needs, as unplanned change of use impacts adversely on earlier calculations and may render whole-life cost information irrelevant.

4.1.1 Procurement and type of contract

The size, nature and management of the structure will influence not only the type and method of repair, but potentially also the form of contract to be used. For large scale refurbishment and repair of aging infrastructure, the public private partnership route is being chosen more frequently. The type of contract drawn up for this method of procurement is very different to the arrangement used for an in-house repair facility.

The preferred procurement route will also depend on the technical knowledge and ability of the Client and his advisors.

4.1.2 Strength of local economy

The method of procurement and type of works undertaken can increase the skill base and technical capabilities of the company and therefore have an effect upon its competitiveness in the marketplace. Competitive advantage does have financial consequences, although precise quantification of these may not be possible. These factors may have an effect upon the strength of the local economy and the wealth of the local area.

4.1.3 Improvement of asset value

Maintaining or improving the value of the asset in question can be a key factor in a decision to intervene made on a commercial basis. Factors which affect this value will not solely be technical ones such as the presence of cracking, but also by the perceptions held by users of the asset and perhaps more widely by the general public. Such perceptions may be very powerful. Even if an asset retains its structural integrity and its functional ability, but looks shabby or dilapidated, it may well be considered to be in an unsatisfactory condition by users and the public.

4.1.4 Whole life costing

Consideration should be given in any financial decision making process to the use of whole-life costing. Such considerations are mandatory in many countries for any government procurement, and are increasingly requested by private clients. Whole life cost equations are relevant both to new build and refurbishment or rehabilitation and their use enables the client to demonstrate best value procurement. The use of whole-life costing should enable clients to avoid low initial costs leading to higher through-life maintenance costs in the future. This impacts on sustainability and careful consideration of whole-life costing is likely to reduce the environmental impact of work over the lifetime of the structure.

Costs to be considered should include the following:

- **Initial construction cost**

This includes all the costs associated with design, construction, testing, supervision, commissioning, inspection, etc required to establish an operational asset. Other secondary economic issues should also be considered such as the training of staff required to operate and maintain the asset.

- **Future maintenance cost**

This would include the cost of future routine maintenance and on-going repairs or related works. If an option with cheaper initial costs but with higher risks of structural failure in the future is considered (eg. do nothing) then the associated costs (taking into account the probability of occurrence) need to be considered. This might include collapse of structure, accidents, fatalities and injuries, potential emergency works etc.

4.1.5 Cost versus benefit to society

The cost for the user during the period when repairs are underway and causing disruption to the users of the facility or the public more generally can have an impact on the choice of the repair method used (eg taking account of traffic delay costs and sustainability impacts). This is currently a very decisive factor in some repair works, such as those upon highway and rail structures. In highway and bridge works, for example, traffic delay costs are generally incorporated in the economic evaluation and are often the dominating factor. The quality of the rehabilitated structure also affects third party costs. If, for example, a bridge has low

functionality it can have an impact on vehicle operating costs and additional factors such as traffic safety.

The overall economic benefits or disbenefits to society can also play an important role in the decision-making process. For example, the upgrading of rural infrastructure can be used to encourage investment and promote regional economic development. This can also have major political impact. If these processes are applied in areas of low economic activity, the beneficial effect can be dramatic.

4.1.6 Loss of revenue during the course of repairs or rehabilitation works

This is a real cost to the owner and should be taken into account. Examples are loss of rental income whilst a building is being repaired, loss of tolls whilst bridge works are undertaken, etc. For work upon infrastructure (bridges, roads, rail) where *lane rental* or other contractual mechanisms are being employed to reflect the impact of the works upon the travelling public and to provide an incentive to the contractor undertaking the works, this could be the critical factor in influencing the choice of rehabilitation scheme.

4.1.7 Indirect economic benefits

Indirect economic benefits may result from a decision to repair or replace ageing or damaged infrastructure. For example, a decision to renovate and upgrade a footbridge to one able to take motorised traffic might create new industry or markets for an isolated community. This consideration may carry more weight for governments or civic authorities making decisions on infrastructure in less favoured regions of a country or in the European Union. In these circumstances political factors may well be more important than financial ones.

4.1.8 User cost

The delay cost experienced by users of the asset during the repair period can have a significant impact on the choice of the repair method to be used. In addition the quality or upgrading of an object can have a bearing upon user cost. For example, if a road or bridge has a low degree of functionality this can have an impact upon factors such as traffic safety.

Consideration of user cost is more likely to influence decisions on the nature of the repair or rehabilitation method to be adopted, or even whether to carry out the works at all. This is currently a very decisive factor in some repair works, especially those upon highway and rail structures. When traffic delay costs and sustainability impacts are incorporated into the economic and environmental evaluation, they generally become the dominating factor.

4.1.9 Public confidence

If a building or some other form of structure gives the impression of being damaged or in bad condition, it can impact negatively upon user confidence. Whilst the structure might still be technically safe, the public may not perceive it be so. This can be extremely costly in the long run, as public perception, rather than the actual technical condition of the asset, will dictate use of a facility and this may have an adverse effect upon the economy of an area or region. These factors will therefore impact upon any decision about whether to repair or replace.

4.2 Social and Cultural Issues

4.2.1 Target groups

Who benefits from the repair works? Is it:

- the owner (what does he get out of it, presumably a long-term benefit)
- the contractor (can presumably demonstrate good practice which will have an impact on his future business)
- the user (who needs a fast repair and is concerned about aesthetics etc)
- or some other group?

This can have an impact on whether or not to repair and also on the repair method selected.

Users are likely to be increasingly involved in the decision process as there is an acknowledged requirement for public consultation.

4.2.2 Education and training

At a general level and somewhat indirectly, improvements in the education of consultants and contractors in Europe (and also their clients) might potentially improve their competitiveness inside and outside Europe. Training, coupled with better education and knowledge obtained from the manuals from the EU-projects CONTECVET and REHABCON, would be expected to improve the chance of choosing the right solution for the structure as one would be more likely to establish the correct cause of damage.

4.2.3 Aesthetics

Today aesthetics often play a very important role not only in the choice of repair method but also on the decision as to when to repair. For example, the upgrading of the appearance of a car park can be of great importance to the surrounding neighbourhood and to the attractiveness and prosperity of the businesses affected. Such actions have been used to act as a catalyst for improvements to the vitality of the whole surrounding area.

4.2.4 Social perception

The repair of structures carried out as part of a regional regeneration scheme can have great impact upon the social perceptions of the area. It can be in the owners' interest to enhance positive social perceptions for example by undertaking cosmetic repair or upgrading within the area. Because society is investing in the neighbourhood, in the long run these actions can have a positive influence upon the level of inhabitancy in dwellings blocks or other types of buildings or in the overall attractiveness of the neighbourhood.

4.2.5 Social alarm

Social alarm can detract from, or even negate, the potential benefits of rehabilitation schemes, particularly when they are carried out in conjunction with regional regeneration. Income from loss of usage will have a direct impact on the value of repair work.

The public can be alarmed by inappropriate or badly implemented repair work, or by their perception of the safety of a structure. Care needs to be exercised when proposing the use materials or new innovative methods with unknown (at the time of selection) long-term behaviour. Previous problems, for example with high alumina cement, have caused a certain degree of social alarm and blight of property when the difficulties and problems have become general knowledge. In such circumstances it is very important that appropriate investigation are made of the affected structures and that there is provision of relevant information to owners and the public.

4.2.6 Reputation

An area or a building can have a poor reputation because of its condition. This can be a social reason for making a political decision upon the upgrading and general improvement of the area to enhance its social status. This is a very important social influence that government and certain other owners can have.

4.2.7 Media and Press

Media interest in a construction or repair project can have an important role, especially where decisions are being made principally on the basis of political influence. This can be used to raise public awareness, encourage participation and consultation, etc.

4.2.8 Government policies and initiatives

Considerable influence is exerted by local and national government targets for social or regional development, reduction of road casualties, sustainability, reduction in construction waste, etc. There may be political priorities which have great importance especially on the decision when and how to repair, potentially over-riding some of the technical requirements.

In some situations, such as work on a very major development or nationally important asset, for labour union aspects to be considered in the planning process and in the decision on the repair method and material to be used.

4.2.9 Legal issues

Legal implications and responsibilities can also influence the decisions to be made, especially on when to repair or to upgrade infrastructure assets such as bridges for example. The owner and others involved with the maintenance or repair of a structure typically have a duty of care to the users of the facility and possibly also more widely to the public. This is not only for what may be done, but also be for what might not have been done. Consider the situation where cracked or spalled concrete has not been removed from a structure and there is a risk of falling debris causing injury or worse to the public or users. In these circumstances not removing the hazard, an act of omission, could be a failure to discharge the duty of care.

Environmental issues can also be important and there may well be direct legally enforceable requirements concerned with emissions to atmosphere or to the water environment when the repair or rehabilitation works are being carried out. For example, it is no longer acceptable for wash-out water from concrete mixers to be discharged directly into the environment. Such wastes are now generally re-cycled into the works processes. Alternatively they would have to be treated and neutralised before release.

On a broader front there may well be wider range of legal implications to be considered, such as those arising from planning laws, consultation requirements, environmental impact legislation, access for utilities, health and safety regulations etc. Some of these issues have been drawn out separately in this report.

4.2.10 Health and safety requirements

It should be recognised that health and safety regulations are becoming progressively more stringent. There is also the expectation that risk assessments will have been performed to seek to identify problems and issues that might arise. If risks are considered as too large for direct acceptance, the expectation is that efforts should be made to look for adequate counter measures. When planning counter measures, the mentioned techniques for the recognition of possible hazards are very helpful. The aim is to detect those events or processes, where with a

small effort, a significant benefit can be obtained. Possible measures can be technical or administrative and can fall within the following strategies:

- *Reduce* the cause of the risk
- *Avoid* the risk by changing the concept or the objectives
- *Control* the risks by using suitable alarm systems, vigilance, inspections, etc
- *Overcome* the risks by providing an adequate capacity.

4.2.11 Insurance and future liabilities

Insurance of assets during the progress of the repair or rehabilitation works can influence the contractor's decision on how he plans to carrying out the works. A potential quandary might arise from whether the contractor should use a robust and a reliable repair method proven through many years of years of experience or should he instead use a new cheaper alternative, but with which there is less experience.

In addition there could no doubt be issues and uncertainties about the long term durability and performance of the new system. It is essential to consider ongoing liability and the duty of care that the designer and contractor owe to the owner, the users of the asset and the general public. All rehabilitation work must be considered in terms of ongoing maintenance and management strategies, as this might affect the repair type, form of contract, proportioning of risk etc.

4.2.12 Working environment

The working environment and how it affects the workers, as well as others such as the general public, is becoming more and more important. Aspects and issues that may have a bearing upon this include:

- Building and work traditions
- Health and safety obligations
- Legal obligations
- Business culture and ability of business to endure / survive and prosper
- Reputation
- Training, education and personnel development
- Trade unionisation / organisation of labour

4.2.13 Repair time

The decision on which repair method is to be used can be strongly influenced by the working time allowed to complete the task. Fast track concrete pavement works on an airport is one example. Many other examples exist in the area of transport, eg highway and rail works, where minimising possession time can often be a most important factor.

These issues also need to be considered as part of the economical evaluation of the technical options, for example by introducing traffic delay costs, lane rental costs , etc as well as the implications of the use of bonuses and penalties etc. Many of these factors have been mentioned above

4.2.14 Risk and safety

The risk and safety for all concerned parties (site staff during execution of repair, users and public during and after repair) will be one of the important issues in respect of the decision on when to repair. There may be legal requirements and government targets to comply with.

4.3 Environmental Issues

As with economic and financial evaluations, there are two main divisions which might be employed as a basis for considering the environmental impact of proposed repair or rehabilitation works:

- Direct impacts – those associated with the materials used and wastes produced / emissions to the environment (atmosphere, water, noise etc) etc during the works.
- Indirect / consequential impacts – such as those associated with traffic delays etc. Studies have shown that these can have a far greater magnitude than the direct impacts.

When seeking to make an evaluation of environmental impact there are several levels that need to be considered: these are explored in the following sections.

4.3.1 Global Environment

Consideration of these high level factors is difficult and requires the use of an accepted methodology, such as the Ecopoints evaluation system produced by BRE (refer Appendix C). The methodology would, for example, be seeking to make an evaluation of the anticipated effects of the proposed repair or rehabilitation works upon climate change, acid deposition, ozone depletion, toxic air pollution, fossil fuel depletion, marine environment pollution, habitat and ecosystems, as well as factors such as the need to preserve primary natural resources by using re-cycled construction materials and wastes in the works.

4.3.2 Local and site (neighbourhood) issues for the built and rural environment

The issues for the built and rural environment might involve consideration of the following:

- Use of natural resources
- Wastes - minimisation, recycling and re-use and disposal
- Energy – employed during manufacture, transport and when in use
- Emissions to environment (atmosphere, water, noise etc)
- Natural habitats and ecosystems
- Life cycle analysis

Consideration should be given to the effects of the repair works upon the surrounding neighbourhood. For example, compaction of concrete and repair materials by the use of vibration equipment (eg. poker vibrators etc) is one factor that causes disturbance to neighbours by virtue of the noise this equipment produces when repair work is being performed. Breaking out of defective concrete by percussive tools is also a very noisy operation. Many countries now have legally enforced restrictions on noise levels.

There is a European policy for reducing the presence of vibration in the working environment, to avoid problems such as the industrial disease ‘white-finger’ associated with the long-term use of vibration tools (eg. poker vibrators, breakers, percussive drills, etc). This

can have an impact on the choice of repair method and the material used. For example, the use of self-compacting concretes has the benefit that it removes the need to introduce vibration energy to achieve compaction. This is one form of response to meeting the legislative requirements.

Dust from the work is also another factor that can cause considerable public nuisance.

Leaching of dangerous material or discharge of wastes (see legal implications above) could have significant impact on the local environment.

Transport of the materials and wastes from repair work needs to be undertaken in an environmental friendly way wherever possible.

4.3.3 Internal environment within facility

These issues will generally be concerned with the health and the comfort of the occupants on issues relating to the working and living environmental, with performance factors generally concerning issues such as thermal, relative humidity, vibration, acoustic measures, etc.

5 ANNEX A Ranking of NTI for specific repair object/repair method

Non-technical issues: ranking NTI for specific repair object/repair method

Primary Classification of Requirement	Non-Technical Issue (NTI)	Level of importance Indicator			
		1 very low	2 low	3 high	4 very high
Economic and Financial	Procurement and type of contract				
	Strength of local economy				
	Improvement of asset values				
	Effect on third parties				
	Whole-life cost				
	Cost versus benefit to society				
	User cost				
Public confidence					
Social and Cultural	Target groups				
	Education and training				
	Aesthetics				
	Social perception				
	Consultation				
	Social alarm				
	Reputation				
	Media and press				
	Government policies and initiatives				
	Labour union aspects				
	Legal issues				
	Health and safety requirements				
	Insurance and future liabilities				
	Working environment				
Repair time					
Risk and safety					
Environment	Global environment				
	Neighbourhood issues				
	Internal environment				



**LUNDS TEKNISKA
HÖGSKOLA**
Lunds universitet