



LUND UNIVERSITY

Material properties related to fire spalling of concrete

Jansson, Robert

2008

[Link to publication](#)

Citation for published version (APA):

Jansson, R. (2008). *Material properties related to fire spalling of concrete*. [Licentiate Thesis, Division of Building Materials]. Division of Building Materials, LTH, Lund University.

Total number of authors:

1

General rights

Unless other specific re-use rights are stated the following general rights apply:

Copyright and moral rights for the publications made accessible in the public portal are retained by the authors and/or other copyright owners and it is a condition of accessing publications that users recognise and abide by the legal requirements associated with these rights.

- Users may download and print one copy of any publication from the public portal for the purpose of private study or research.
- You may not further distribute the material or use it for any profit-making activity or commercial gain
- You may freely distribute the URL identifying the publication in the public portal

Read more about Creative commons licenses: <https://creativecommons.org/licenses/>

Take down policy

If you believe that this document breaches copyright please contact us providing details, and we will remove access to the work immediately and investigate your claim.

LUND UNIVERSITY

PO Box 117
221 00 Lund
+46 46-222 00 00

LUND INSTITUTE OF TECHNOLOGY
LUND UNIVERSITY

Division of Building Materials

Material properties related to fire spalling of concrete

Robert Jansson

ISRN LUTVDG/TVBM--08/3143--SE(1-62)
ISSN 0348-7911 TVBM

Lund Institute of Technology
Division of Building Materials
Box 118
SE-221 00 Lund, Sweden

Telephone: 46-46-2227415
Telefax: 46-46-2224427
www.byggnadsmaterial.lth.se

Abstract

Despite almost 100 years of research, the fundamentals of fire spalling of concrete are not yet fully understood. Many different theories exist, each trying to describe the coupling between different phenomenon leading to fire spalling. Some of these phenomenon have been investigated and are presented in this thesis.

The thermal properties at high temperature have been investigated using the Transient Plane Source (TPS) technique. Measurements of temperature in the cross-section of self-compacting concrete with the addition of polypropylene fibres (PP-fibres) during fire exposure are presented. A verification calculation, based on the measured values of temperature in the cross-section of the fire exposed concrete, was compared with results from a full-scale fire test with the same concrete. Good correlation was obtained.

Using a measurement system consisting of oil filled steel pipes, the pressure inside the concrete during fire exposure, was measured. Results from pressure measurement tests on self compacting concrete show relatively low internal pressure before spalling. In fact, the pressure was highest in a specimen that did not spall during fire exposure. Conclusions from the tests were that pore pressure only played a secondary role in the spalling process of the concrete investigated. Thermal stresses were believed to be the primary reason for spalling.

With a small addition of polypropylene fibres (PP) in concrete the fire spalling can be limited or totally avoided. Comparative studies of concrete with and without PP- fibres were performed, and the function of PP-fibres was illustrated in small and large scale fire tests. When determining the free thermal expansion as a function of temperature a strain plateau was found in specimens containing PP-fibres. The plateau corresponds fairly well with the temperature where accelerated drying behaviour was shown. This is an indication that an accelerated drying creep phenomenon might be present. Further experimental work is needed to verify this postulate.

Key words: Copncrete, Thermal properties, Fire spalling, polypropylene fibres

List of publications

This thesis is based on the following publications:

- Publication I. Jansson R. "Measurement of Concrete Thermal Properties at High Temperature" Proceedings from the fib Task Group 4.3 workshop "Fire Design of Concrete Structures: What now? What next?", Milan, Italy, December 2-3, 2004
- Publication II. Jansson R. "Liquid/steam pressure measurement inside concrete exposed to fire" Proceedings from the 4th international workshop Structures in Fire, Aveiro, Portugal, 2006
- Publication III. Jansson R. Boström L. "Fire spalling: Theories and experiments" Proceedings from the fifth International RILEM Symposium on Self-Compacting Concrete, 3-5 September 2007, Ghent, Belgium
- Publication IV. Jansson R. Boström L. "Experimental study of the Influence of Polypropylene Fibres on Material Properties and Fire Spalling of Concrete" Proceedings from the fib Task Group 4.3 workshop "Fire Design of Concrete Structures – From Materials Modelling to Structural Performance" Coimbra, Portugal, November 8-9, 2007

In addition to the publications included in the thesis the author has also contributed to the following publications:

- Publication V. Jansson R. "Measurement of the Thermal Properties" Proceedings from the 10th international Fire science & Engineering Conference (Interflam '04), Edinburgh, Scotland, 2004
- Publication VI. Boström L., Jansson R. "Spalling of Concrete for Tunnels" Proceedings from the 10th international Fire science & Engineering Conference (Interflam '04), Edinburgh, Scotland, 2004
- Publication VII. Jansson R. "Measurement of Thermal Properties at High Temperatures- Brandforsk project 328-031" SP Report 2004-46, Borås, Sweden, 2004
- Publication VIII. Jansson R., Boström L. "Experimental Methods for Determination of Spalling" Proceedings from the fib Task Group 4.3 workshop "Fire Design of Concrete Structures: What now? What next?", Milan, Italy, December 2-3, 2004
- Publication IX. Boström L., Jansson R. "Spalling of Self Compacting Concrete" Proceedings from the 4th international workshop Structures in Fire, Aveiro, Portugal, 2006
- Publication X. Boström L., Jansson R. "Fire Resistance" Chapter 4.6 in the report Durability of Self-Compacting Concrete, RILEM TC 205-DSC: State-of-the-Art Report, RILEM Report 38, 2007
- Publication XI. Boström L., Jansson R. "Fire spalling of Self-Compacting Concrete" Proceedings from the fifth International RILEM Symposium on Self-Compacting Concrete, 3-5 September 2007, Ghent, Belgium
- Publication XII. Hjolman M., Boström L., Jansson R. "Overview of Testing of Concrete and Concrete Protection Systems for Tunnels in Sweden" Proceedings from the fib Task Group 4.3 workshop "Fire Design of Concrete Structures – From Materials Modelling to Structural Performance" Coimbra, Portugal, November 8-9, 2007

Preface

The work presented in this thesis has been conducted mainly with the support from the Swedish Research Council for Environment, Agricultural Sciences and Spatial Planning, FORMAS, (registration number: 243-204-1992). Some work conducted within other research projects at SP Technical Research Institute of Sweden, Department of Fire Technology, has also been included in the thesis. These research projects have been supported by Brandforsk (project 328-031) and Swedish Road Administration (registration number: AL 90B 2005:16378).

I have been enrolled at Lunds University, Department of Building Materials with Professor Lars-Olof Nilsson as the responsible supervisor. I would like to thank Professor Lars-Olof Nilsson and Dr. Lars Wadsö for providing an excellent breeding ground for critical thought by organising the monthly PhD days at the Department of Building Materials. The discussions and wide spectrum of subjects treated have really inspired my personal and professional development.

Supervisor, manager, colleague and friend on site at SP Fire Technology has been Dr. Lars Boström who I specially thank for sometime asking the short but important question “Why?”.

I would also like to thank Dr. Yngve Anderberg for, among other things, reminding me to mention the well known fact that dried ordinary low strength concrete usually does not spall in the same manner as denser concrete during fire exposure. This is very important to remember.

The technicians at SP Fire Technology are also worthy of all my gratitude together with my German “slave” Simon Fritz who did an excellent job during core drilling and fire testing as part of his summer internship in 2006 and summer position in 2007.

Further my French friends at CSTB, Dr. Pierre Pimienta and Jean-Christophe Mideguia, must be recognised for their kindness and very serious approach to those parts of the thesis in which they have participated. Many detailed discussions have lead to even more new ideas.

Finally, I would like to thank my partner, Margaret Simonson, for among many other things sometimes asking me the important question “What do you mean?”

List of contents

Abstract	iii
List of publications	v
Preface	vii
List of contents	ix
1 Introduction	1
1.1 Background	1
1.1.1 Concrete and fire	1
1.2 The purpose of this work	5
1.3 Limitations of the work	5
2 Spalling Theories	7
2.1 Under which circumstances does concrete spall?	7
2.2 Fire spalling theories	10
2.3 Summary	17
3 Experimental study	19
3.1 Capillary saturation	19
3.2 Fire resistance testing	21
3.2.1 Small furnace tests	21
3.2.2 Large furnace tests	24
3.3 Moisture pressure measurements	28
3.4 Thermal characteristics of concrete	29
3.5 Drying tests	34
3.6 Permeability	35
3.7 Speed of sound	37
3.8 Thermal expansion	38
4 Resume of articles	41
4.1 Article I: Measurement of Concrete Thermal Properties at High Temperature	41
4.2 Article II: Liquid/steam pressure measurement inside concrete exposed to fire	41
4.3 Article III: Fire spalling: Theories and experiments	42
4.4 Article IV: Experimental study of the influence of polypropylene fibres on material properties and fire spalling of concrete	42
5 Discussion	43
Hypothesis A: Pressure effect from moisture	45
Hypothesis B: Effect of moisture on mechanical properties	46
Hypothesis C: Drying creep effect	49
6 Conclusions	51
7 Future research	53
8 References	55

1 Introduction

1.1 Background

Concrete is used extensively as a building material. Long experience has proven that traditional reinforced concrete has both good mechanical properties and good fire properties. Modern applications have led to the development and use of new types of concrete. Fire spalling of concrete is not a new phenomenon but renewed focus has been set on the problem due to the fact that in some new applications certain new types of concrete have been shown to spall severely compared to traditional concrete.

Sometimes, when concrete is exposed to fire, material from the hot fire exposed surface is flaked away in a more or less violent manner. Under some circumstances, the whole cross-section of an element or detail exposed from more than one direction can disintegrate instantaneously, e.g. the web of a beam. The mechanisms leading to surface flaking of an element or instantaneous explosion of a web are not necessarily the same, although the term used to describe this behaviour is “spalling” throughout this thesis. Many researchers divide spalling into several sub-categories, depending on how violent it is or whether it is located in the aggregate or in the corner of the construction. The definition used in this thesis is in line with the definition made by Preston & White (1934), i.e., a “spall” is a flake from the surface. Spalls must fly off, i.e., they must form suddenly with enough violence to make at least something of a “pop” or audible noise.

If a concrete structure exhibits spalling during a fire test simulating a fire that reaches the flashover phase, it usually starts between 3-30 minutes from the start of the exposure. At slower heat exposure, the spalling behaviour may start later.

One might reasonably consider how common fire spalling is. In an inquiry made by The Concrete Society Committee of Fire Resistance over 80 % of nearly 100 fire accidents in concrete buildings reported mentioned the occurrence of fire spalling, Malhotra (1984). An important conclusion from the study was that none of the investigated events led to collapse of the structure. Fire investigations at SP, e.g., Boström (2006), on fires under concrete road bridges also show that while surface spalling is common on fire exposed old concrete, none of the bridges investigated were close to collapse.

1.1.1 Concrete and fire

In 1854, the fact that concrete with flint aggregate would exhibit the following behaviour: “if there were flintstones in it the concrete would split, and yield under the action of fire”, was described by Barret (1854).

Some years later Thaddeus Hyatt (1878) performed a large number of tests on concrete beams with different types of reinforcement. He also compared the thermal expansion of wrought iron and concrete and concluded that it was almost the same. Concrete in combination with iron was shown to be an excellent material in a fire situation. The insulating properties of concrete were good and the function of the elements was maintained during prolonged fire exposure. Some of the tested concretes include something as modern as different types of fibres and he concluded that not even asbestos fibres improved the fire resistance. Thaddeus Hyatt's (1878) experiments also show that the moisture content in concrete contributed to keeping the temperature down during fire exposure.

The first systematic attempt to categorise different kinds of fire spalling of concrete was probably made by Gary (1917) in his review of work conducted between 1910-16. He found from fire tests on specially built houses, that fire spalling could occur in the following forms:

- *Aggregate spalling* - crater formed spalling attributed to the mineralogical character of the aggregate,
- *Surface spalling* – disc shaped violent flaking, especially in pressure stressed walls, probably caused by water damp,
- *Corner spalling* – violent spalling of corners (by later researchers, Khoury (2000) described as non-violent), probably caused by water damp as well as temperature stresses due to bilateral fast heating up, and
- *Explosive spalling* – very violent spalling of large, up to 1 m², pieces from walls. Some pieces were thrown 12 meters by the force. Gary (1917) had no explanation for this type of spalling.

During the early 20th century a large effort was put into fire testing of large un-reinforced and reinforced concrete test specimens. As a reaction to this, Lea (1920) performed a series of small scale material tests to understand the fundamentals of the material behaviour of steel and concrete at high temperatures. According to Lea, it was unwise to spend money on large scale tests before the fundamentals were understood. He investigated the thermal behaviour of different concrete mixes and also the residual compressive and tensile strength on unloaded specimens after heat treatment up to 700 °C. A conclusion from the study was that the internal temperature in a fire exposed concrete cross-section can vary considerably for concretes made with different aggregates.

As a part of a fire investigation after a fire in a storage building made of concrete, Nils Sundius (1931) studied the changes in concrete after a fire using microscopy. He found that physical changes such as crack growth in the cement paste, were induced by the expulsion of water. He also found large cracks parallel to the heated surface, which he concluded could lead to flaking.

In a Swedish publication by Sönerberg (1952), it was hypothesised that concrete manufactured using the “modern” method of machine vibration of concrete, in contrast to traditional manually compacted concrete, leads to reduced fire resistance. The reason for this was, according to Sönerberg, that free and chemically bound water was more restricted from leaving the concrete structure during fire exposure in “modern” concrete. This resulted in raising of the steam pressure until the surface layer was spalled off.

A handbook for the residual assessment of fire exposed concrete was published by the Swedish Tariff Association (1959). A more modern source of information regarding residual assessment is a special issue of the Fire Safety Journal (Vol. 16 No.4 1990) where the report “Reparability of Fire Damaged Structures” by the committee CIB W14, was published.

A detailed examination of the effects of a fire in a storage house in Stockholm in 1966 showed severe fire spalling of the concrete at some locations, Lindblad et al.(1966), as shown in Figure 1. The fire occurred during the construction of the building and it was concluded in the fire investigation that if the flat slab construction had been loaded with its working load, it would have collapsed.

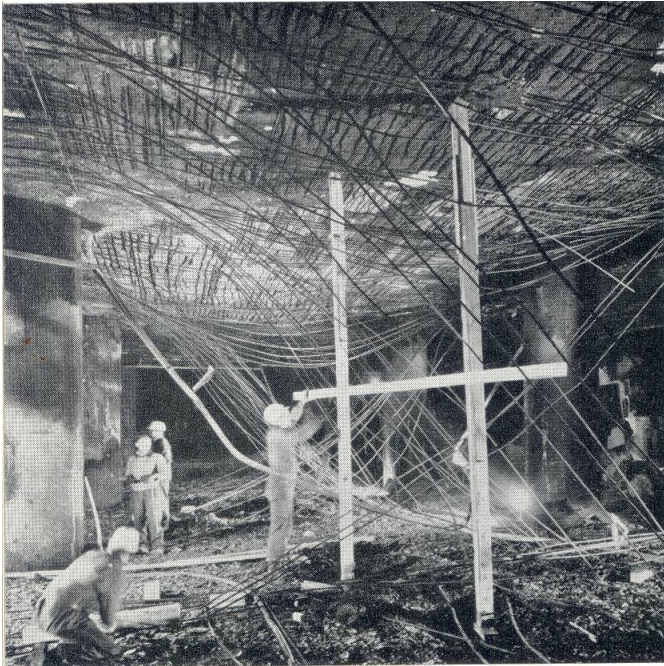

Figure 1 Severe damage by spalling, bottom reinforcement partly fallen down , reproduced from Lindblad et al. (1966)

During the late sixties and seventies, research on concrete at high temperatures was intense. Some noteworthy investigations were performed on:

- thermal properties by Zoldners (1968), Harmathy (1970) and Ödeen & Nordström (1972)
- compressive strength by Abrams (1968)
- tensile strength by Thelandersson (1972)
- transient creep by Schneider (1976) and Anderberg & Thelandersson (1976)
- fire spalling phenomenon by Harmathy (1965), Meyer-Ottens (1972), Dougill (1972), Waubke & Schneider (1973), Zhukov (1976) and Copier (1979)
- fire spalling of light weight concrete by Shirayama (1976) and Copier (1979)
- modelling of heat and moisture transport by Bennet et al. (1976) and Bazant & Thonguthai (1979).

During the late seventies and until the present day there has been continuous work in the technical committees of RILEM on the subject of concrete at high temperature. Some important publications from the committees include:

- “Properties of Materials at High Temperatures - Concrete”, Schneider (1985), a report including a compilation and review of experimental data.
- “Mechanical Testing of Concrete at High Temperatures”, Schneider & Schwesinger (1990), which includes a discussion of some important aspects of testing concrete at high temperatures.
- The test methods published in Materials and Structures by RILEM TC 129 MHT and TC 200 HTC:
 - RILEM TC 200 HTC “Test methods for mechanical properties of concrete at high temperatures - Part 1: Introduction”, Materials and Structures (2007) 40:841–853

- RILEM TC 200 HTC “Test methods for mechanical properties of concrete at high temperatures - Part 2: Stress-strain relation”, *Materials and Structures* (2007) 40:855–864
- RILEM TC 129 MHT “Test methods for mechanical properties of concrete at high temperatures - Part 3: Compressive strength for service and accident conditions”, *Materials and Structures*, Vol. 28, 1995 pp. 410-414
- RILEM TC 129 MHT “Test methods for mechanical properties of concrete at high temperatures - Part 4: Tensile strength for service and accident conditions”, *Materials and Structures*, Vol. 33, May 2000, pp. 219-223
- RILEM TC 129 MHT “Test methods for mechanical properties of concrete at high temperatures - Part 5: Modulus of elasticity for service and accident conditions”, *Materials and Structures*, Vol. 37, March 2004, pp. 139-144
- RILEM TC 129 MHT “Test methods for mechanical properties of concrete at high temperatures - Part 6: Thermal strain”, *Materials and Structures*, Supplement March 1997, pp. 17-21
- RILEM TC 129 MHT “Test methods for mechanical properties of concrete at high temperatures - Part 7: Transient creep for service and accident conditions”, *Materials and Structures*, Vol. 31, June 1998, pp. 290-295
- RILEM TC 129 MHT “Test methods for mechanical properties of concrete at high temperatures - Part 8: Steady-state creep and creep recovery for service and accident conditions”, *Materials and Structures*, Vol. 33, January-February 2000, pp. 6-13
- RILEM TC 129 MHT “Test methods for mechanical properties of concrete at high temperatures - Part 9: Shrinkage for service and accident conditions”, *Materials and Structures*, Vol. 33, May 2000, pp. 224-228
- RILEM TC 200 HTC “Test methods for mechanical properties of concrete at high temperatures - Part 10: Restraint stress”, *Materials and Structures*, Vol. 38, Dec. 2005, pp. 913-919
- RILEM TC 200 HTC “Test methods for mechanical properties of concrete at high temperatures - Part 11: Relaxation” *Materials and Structures* (2007) 40:449–458

During the past three decades several handbooks and guidelines on designing concrete for fire resistance have been published, including:

- PCI: Design for Fire Resistance of Precast Prestressed Concrete, Gustafsson et. al. (1977)
- Fire Safety Engineering, Pettersson & Ödeen (1978, available in Swedish only)
- Beton Brandschutz Handbuch, Kordina & Meyer-Ottens (1981)
- ACI: Guide on Determining of Fire Endurance of Concrete Elements (1981)
- CEB/FIP Model Code 90: Fire Design of Concrete Structures (1991)
- Fire Safety Engineering of concrete structures, Anderberg & Pettersson (1991, available in Swedish only)
- Fire safety Design & Concrete, Harmathy (1993)
- Concrete at High Temperatures – Material Properties and Mathematical Models, Bazant & Kaplan (1996)
- Eurocode 2: Design of Concrete Structures – Part 1-2: General Rules- Structural fire design (2004)
- *fib*: Fire Design of Concrete Structures – Materials, structures and modelling (2007)

During the eighties and nineties, some investigations of high strength concrete at high temperatures pointed out that dense concrete is more sensitive to spalling, Hertz (1984), Sanjayan & Stocks (1993), Ali et. al. (1996). The sensitivity to fire spalling of high strength concrete has also been observed in several tunnel fires as described by Khoury (2000). The most well known is probably the fire in the Channel Tunnel in 1996. In some areas during that fire, the whole cross-section of the 110 MPa (mature) HPC was spalled away so the grout was exposed. In another fire, in the Great Belt tunnel in 1994, up to 68% of the cross section of the 76 MPa (28 days) HPC was destroyed by spalling.

1.2 The purpose of this work

The purpose of the work presented in this thesis was to study fire spalling of concrete. The aim was initially to develop a theoretical method for the prediction of fire spalling. Due to the magnitude of this task it was decided to focus this first thesis work on experimental investigations and their bearing on existing theoretical models with an aim towards developing new and improved theoretical models in the next phase of this work.

Studies have been performed of an experimental nature with the aim of investigating some properties related to fire spalling. In particular, the role of moisture in the fire spalling process was investigated. Ultimately it is hoped that the work presented will provide a sound basis for future theoretical modelling of fire spalling.

1.3 Limitations of the work

Given the fact that fire spalling of concrete is highly dependent on a number of parameters including the moisture of the concrete, the aggregate, the composition of the concrete paste, the presence or absence of an external load, etc, it has not been possible to study all these parameters given the limited time available. A number of issues have been focussed on and tests designed to minimise variation of the other parameters. Aggregate spalling and the non-violent degeneration of concrete in the later phases of fire exposure, so called falling-off of concrete caused by gravity, is not dealt with in this thesis.

2 Spalling Theories

2.1 Under which circumstances does concrete spall?

It is well known that concrete with low strength and low moisture content seldom spalls during fire exposure. One example of this is that the concrete slabs (mounted as filling material between test specimens on the horizontal furnace at SP), with cubic strength approximately 30 MPa, do not spall even when the fire exposure is very severe. ,

During the early 1970's, a questionnaire about fire spalling was sent out to 20 different laboratories, Malhotra (1984). Replies were received from 13 of the laboratories and only a minority had not experienced spalling. Six factors that influenced the occurrence of spalling were identified, i.e. the aggregate type and size, concrete density, age, moisture, and restraint to expansion. This list was also refined and graded from most important to least important as: **the nature of the aggregate, free moisture, and restraint to expansion.**

The nature of the aggregate influences the occurrence of fire spalling in several ways. The structure and the mineral composition are the most important factors influencing the thermal expansion of the aggregate according to Zoldners (1968). An important factor is the magnitude of quartz in the rock material. Quartzite and sandstone with high quartz content exhibit high thermal expansion in contrast to limestone without quartz which has a low thermal expansion coefficient. At 573 °C, quartz undergoes a sudden thermal expansion when α -quartz transforms to β -quartz. This expansion is non-reversible and can be used as an indicator of the magnitude of the temperature exposure in post fire investigations. Air-dry rock has a higher thermal expansion coefficient than water saturated rock. The difference is 10 % according to Dettling as cited by Zoldners (1968). Logically this difference must be dependant on the porosity of the rock material.

Moisture content plays an important role in the phenomenon leading to fire spalling. If the moisture content of the concrete is low, the probability of spalling is low as concluded by Meyer-Ottens (1972) and Copier (1979). Whether it is the absence of free moisture or the method of reducing moisture that limits spalling is a interesting question. A forced drying processes or long drying time changes the concrete so identical specimens with and without a high moisture content are hard to manufacture. A drying process, in an externally dry climate, induces micro cracks by shrinkage of the cement past. In contrast, when continuous hydration is dominant in reducing moisture, as in the case of concrete with low water/cement ratio, the pore structure changes. Independent of the drying method, the process of drying changes the concrete sample fundamentally, i.e., it is not possible to have two identical specimens with different moisture contents. Despite the inherent uncertainty concerning why moisture content is important in spalling, moisture content does appear to be an indicator of the spalling risk. Under a certain moisture content some authors regards concrete as "safe" from explosive spalling. In Eurocode 2 (EN 1992-1-2:2004) a limiting value of 3 % moisture content by weight is recommended although the value can be changed in the national annex. Also Hertz (2003) and Bushev et al. (1970) point out the limit of 3 %.

Restraint to expansion has also been identified as a key factor. Copier (1979) states that when a compressive stress is present, spalling is promoted, but the size of the compressive stress is less important. This conclusion was also drawn by Boström & Jansson (2007) when testing self compacting concrete, fire exposed from one side.

Concrete which is exposed to a fire from more than one side is more sensitive to spalling. Probably the most well-known experimental series dealing with this issue was conducted by Meyer-Ottens (1972) at the University of Braunschweig. One conclusion from that study was that thin cross-sections and high load, promote spalling. This nomogram of the influence of load and thickness on the spalling risk from the study has since then been widely cited in the literature and was also included in earlier versions of the Eurocode 2 (ENV 1992-1-2:1995), see Figure 2.

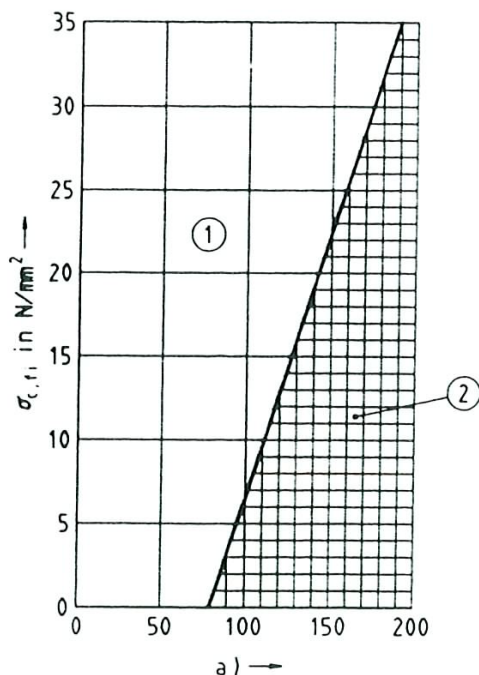

Figure 2 The risk of spalling in two side exposed cross-sections. The X-axis is the thickness in mm while the Y-axis, $\sigma_{c,fi}$, is the compressive stress in the fire situation. Area (1) denotes where there is a risk of explosive spalling, while area (2) shows where explosive spalling is unlikely to occur. (Reproduced from Eurocode 2: ENV 1992-1-2:1995).

This nomogram is omitted from the most recent version of Eurocode 2 (EN 1992-1-2:2004), probably due to the fact that these two factors, thickness and load, are not the only important parameters influencing spalling. Tests at SP, conducted by Bengtsson (1997, on beams with 80 mm webs, which corresponds to the boundary between where explosive spalling would be likely or unlikely to occur according to Meyer-Ottens (see Figure 2), exhibited severe spalling with ensuing collapse, see Figure 3. Further, an unloaded specimen spalled severely. The age of the test specimens were 4-5 months and one of the test specimens was pre-dried at 90-120°C for 6.5 hours. The extra drying was performed two days before the fire test and the mean moisture content by weight was measured as 3.1% in a specimen preconditioned the same way and with the same thickness as the web, i.e., $80 \times 250 \times 250 \text{ mm}^3$. This did not eliminate the spalling behaviour. Four and a half years later one more test was performed on a beam moulded at

the same time. During this test, no spalling was seen during 60 minutes of standard fire exposure.

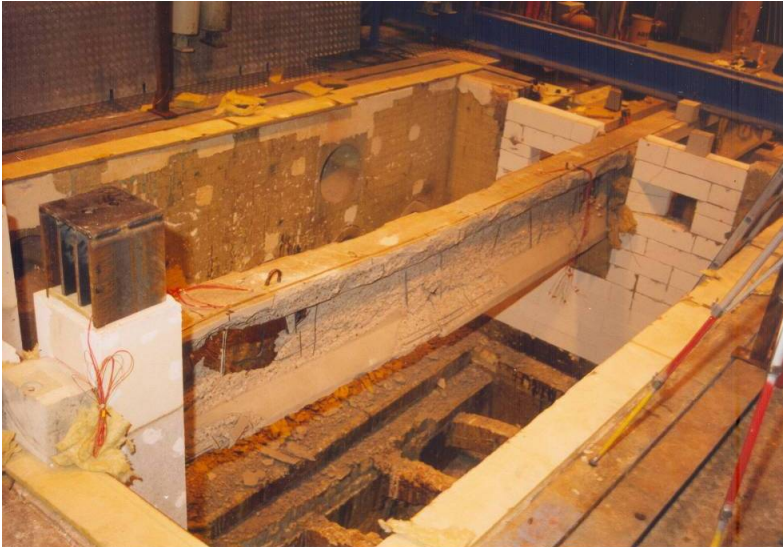

Figure 3 Spalled beam with slender cross-section, Bengtsson (1997)

These results illustrate the fundamental difficulty in predicting spalling. Test objects, produced at the same time and exposed to the same type of fire exposure after different drying processes behave differently under the influence of a fire.

It is, however, clear that the following parameters influence the propensity of concrete to spall, Swedish Concrete Association (2004), based on experience from extensive fire tests:

- External factors, i.e.,
 - Fire scenario (time temperature curve)
 - Heat exposure (one-, two-, three-, or four-sided exposure)
 - External load
- Dimensions and reinforcement, i.e.,
 - Outer geometry
 - Concrete cover thickness and reinforcement
- Concrete composition and properties, i.e.,
 - Aggregate (type and size)
 - Cement and filler (type and amount)
 - Air content
 - Fibre content
 - Moisture content
 - Permeability
 - Strength properties

Two of the above identified parameters are the aggregate size and fibre addition. In Article IV of this thesis the influence of aggregate size and poly propylene (PP) fibre addition on spalling, is discussed. The concretes with maximum aggregate size 25 mm almost always spalled more than the similar concretes with maximum aggregate size 16 mm and concrete with PP-fibres spalled less than concrete without fibre addition, see Figure 4.

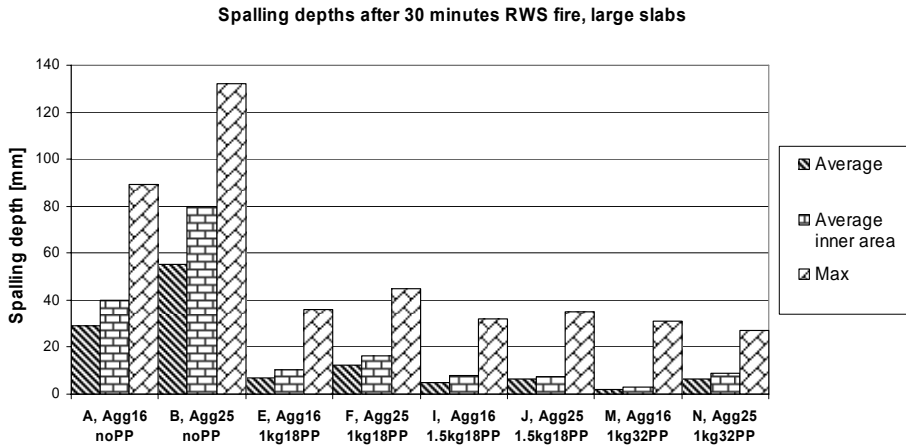

Figure 4 Comparison of spalling depth during one-sided exposure and different aggregate sizes and PP- fibre additions. More details about the concretes and test conditions can be seen in Article IV of this thesis.

The fact that there are numerous parameters which effect the propensity of concrete to spall has lead to the postulation of several theoretical explanations to spalling. Due to the complex nature of spalling, these theories represent a simplification of the real phenomenon based on observations of spalling behaviour. This means that none of the existing theories have been able to reliably predict spalling under all conditions. They do, however, provide an interesting starting point for understanding the significance of the various parameters listed above. The next part of this chapter provides a short description of the most well established theories, rounded off with a discussion of a more complex approach which includes aspects of several theories.

2.2 Fire spalling theories

Some pioneering work on fire spalling has been performed in Germany. By performing tests on thermal expansion and changes in the structure of the aggregate during heating, Endell (1929) concluded that the driving force for spalling was the sudden volumetric change of the quartzitic components of the aggregate at 500 °C. Bottke (1931) theorised that the stresses caused by differential thermal expansion in a cross-section lead to fire spalling. He also concluded that the difference between the thermal expansion of concrete and the reinforcement intensified the spalling behaviour. In a thesis produced at the University of Braunschweig, Hasenjäger (1935) summarised the available data at that time and concluded that fire spalling was caused by:

- Rapid heating of concrete
- Exceeding of the tensile strength by one sided strain
- Rapid structure and volume change in the aggregate
- Pressure from liberation of water vapour and gases from the aggregate and the cement paste

As seen in the list above, Hasenjäger (1935) identified two types of stresses leading to the spalling phenomena: thermal stresses and pressure from moisture. The relative importance of these two factors has since been the subject of intense discussion by the scientific community.

To illustrate the whole palette of spalling theories, a survey performed by Malhotra (1984) provides an overview of which theories various researchers consider to be the primary and secondary causes of spalling during the 60's and 70's. The different causes are summarised in Table 1.

Table 1 Main spalling theories with sub groups, Malhotra (1984)

1) Moisture	1a) Vapour pressure
	1b) Moisture clogging
	1c) Vapour pressure enhanced by frictional resistance
2) Stress	2a) Initial compression
	2b) Initial compression + thermal stress
	2c) Initial compression + thermal stress + stress caused by frictional resistance
3) Cracking	3a) Aggregate expansion
	3b) Internal cracks
	3c) Reinforcement expansion

In Table 2, the different theories are graded by different researchers.

Table 2 Highlighted theories by different researchers, Malhotra (1984)

Researcher	Main factors	Secondary factors
1) Saito	2a, 2b, 2c	1a
2) Harmathy	1b	-
3) Meyer-Ottens	1c, 2b	2c, 3c
4) Dougill & Sertmehmetoglu	1b, 3b	2a
5) Akhtaruzzaman and Sullivan	1a	Dense surface layer
6) Gustaferro	1a	3a
7) Copier	2a, 1a	--

As seen in the above overview, there is some disagreement concerning the origin of spalling.

Moisture is clearly an important factor. One classical approach to the role of moisture was formulated by Shorter & Harmathy (1961), i.e., the **Moisture Clog Theory**. When a concrete specimen is heated, the steam pressure in the pores rises close to the surface. The pressure gradient then drives moisture not only out of the specimen but also towards the inner colder regions. When the steam meets a neighbouring colder layer it will condense. This process will continue, moving further into the cross-section, until a fully saturated region of "considerable thickness", Harmathy (1965), will be created. This region is the so called "moisture clog". When the moisture clog is created, further movement of steam inwards towards the colder regions is restricted which will lead to the situation shown in Figure 5. The figure is obviously a simplification because in a real situation the temperature and pressure fields will not be linear, but the main point is that the highest pressure will be developed at the boundary between the moisture clog and the steam moving inwards, and when (or if) this pressure exceeds the tensile strength of the concrete, a piece will spall away.

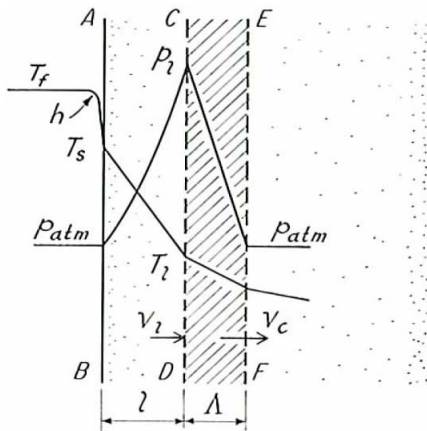

Figure 5 The fully developed moisture clog, reproduced from Harmathy (1965).

The transient temperature development in the cement matrix of a normal concrete does not typically, as one might expect, exhibit a plateau at 100 °C (i.e., the boiling point of water under normal pressure and temperature) as seen in some test results. This plateau when it exists is often an experimental anomaly due to the fact that a cavity around the thermocouple becomes water filled and the thermocouple measures the temperature inside the cavity. The cavity can be natural in the cement matrix or can be a result of cracking during heating. When using small, unshielded welded thermocouples mounted during moulding as done in the worked presented in this thesis, see Figure 6., This plateau behaviour is very seldom seen.



Figure 6 Welded thermocouple wire, diameter 0.5 mm.

The physical explanation for the absence of a distinct boiling plateau is twofold. First the boiling point of water is pressure dependant, at a higher pressure the boiling point is higher. As an example, if the pressure is two atmospheres (which is not unusual in fire exposed concrete) the boiling point for ordinary water on a flat surface is 120°C. As described by Theladersson (1974), the capillary forces acting on the water inside a porous media will also lead to a higher evaporation temperature, as the surface tension is temperature dependant. This effect is naturally more pronounced in dense concrete with

less capillary pores. The evaporation temperature of water is therefore dependant on the pore size as shown in Figure 7.

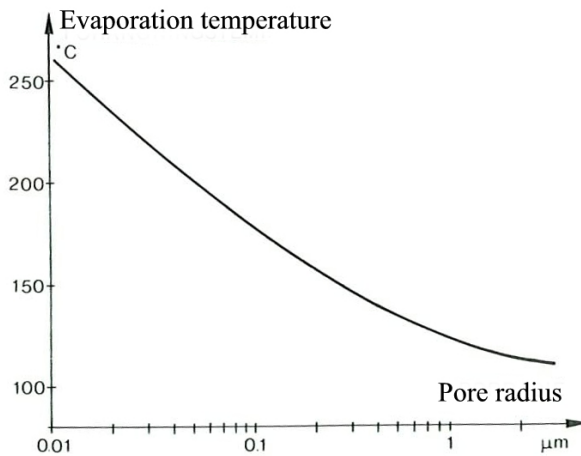

Figure 7 Evaporation temperature as a function of the pore radius, Waubke (1973).

These two effects (pore size and pore pressure) result in a variable boiling point for water in concrete under the effect of a fire. This is recognised in the Eurocode 2, EN 1992-1-2:2004, where the latent heat of evaporation is superimposed on the specific heat in a temperature interval, see Figure 8. The use of the superimposed latent heat as in the Eurocode was shown to give good results in a calculation described in Article I of this thesis.

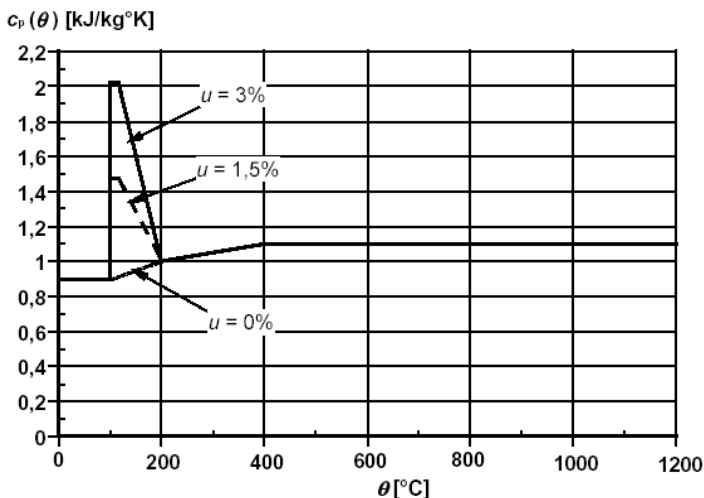

Figure 8 Latent heat of evaporation is superimposed on the specific heat capacity c_p in a temperature interval from 100 °C to 200 °C, reproduced from Eurocode 2 (EN 1992-1-2:2004).

The presence of moisture is also the driving force in the **Hydraulic Spalling Theory**. According to this hypothesis, spalling is caused by the hydraulic fracture of a saturated pore, Khoylou (1997), Breunese & Fellingner (2004). The thermal expansion of water is higher than the available volume in the surrounding porous skeleton. If a closed pore is

occupied by more than 32 % water, the water will expand during heating from room temperature and the whole pore will be filled. The air present in the pore will be forced into solution in the water and, due to the very low compressibility of water, the hydraulic pressure will rise very rapidly when the whole volume is filled. In fact this principle is used as the activation mechanism for sprinklers with bulb activation, where a glass container is filled with water and a bubble. When the temperature rises sufficiently the water expands and the air is forced into solution in the water until the whole bulb is filled and breaks due to the build up of hydraulic pressure. The above analysis is valid for a closed pore system. In a real system some moisture transport will be present, but this will be restricted in low permeability concrete, meaning that hydraulic pressure could provide at least a partial explanation for documented spalling depending on the permeability of the concrete.

Spalling theories based on **Frictional Forces** during vapour flow inside concrete have been proposed by Waubke (1966), Meyer-Ottens (1972) and Waubke & Schneider (1973). The flow of vapour in concrete will give rise to wall friction which results in tensile stresses in the capillary system. The fundamental idea of the work by Waubke & Schneider (1973) was to conduct a reverse calculation, Schneider (2007) assuming that all moisture must be expelled during heating. A theoretical calculation, including a comparison of the influence of different parameters on this evacuation, then concluded that frictional stresses originating from vapour flow during fire exposure, made spalling probable.

Thermal Stresses created by restrained thermal expansion is one of the most widely recognised spalling theories. Compressive stresses close to the surface were proposed by Sato (1965) to be the main driving force for fire spalling. Sato postulated that these stresses originated from thermal expansion close to the surface that is restrained by the inner, colder part of the structure. According to this theory, the stresses are highest when the thermal gradient is high. He based his conclusions on an analysis of the stresses assuming elastic material, a clear simplification. This analysis does not include the fact that the transient thermal creep will reduce the stresses during heating. Sato's theory predicted that spalling will take place within 30 minutes during a standard fire exposure. This has been confirmed by experiments. Similarly, the unfavourable effect of pre-stress or external compressive load on spalling could be explained with his theory (he superimposed the extra stress upon the thermal stress). The effect of moisture on spalling is explained by Sato (1965) as being a result of higher thermal gradients close to the surface when much moisture is present.

The theory by Sato (1965) was, according to Dougill (1971), incomplete. The major objections were that concrete is not a linear elastic material and failure does not necessarily occur at a point where the compressive stress reaches its maximum value. Further, the theory does not explain violent, rapid, spalling behaviour. According to Connolly (1995), Dougill noted that the stress field during the early stages of heating is analogous with the stress field produced during a splitting test of a cylinder in a stiff testing machine, see Figure 9

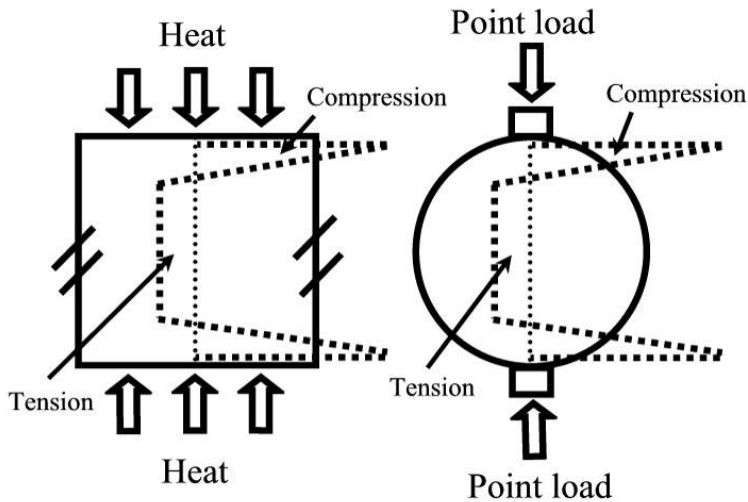

Figure 9 Similar stress fields from two sided heating and splitting test of a cylinder, Connolly (1995).

Another comparison made by Dougill was that explosive spalling is the same mode of failure as violent failure exhibited when testing a concrete (with a strain softening region) specimen in a flexible testing machine, Dougill (1972). When concrete is heated from two sides, the thermal expansion is restricted by the stiffness of the unheated inner regions. The inner regions under tension are analogous to the flexible testing machine and the outer regions in compression are analogous with the test specimen in a compressive test. The strain softening behaviour under compression close to the surface at high temperatures, along with the “spring” effect of the internal tension region, leads to violent failure of the whole cross-section when the peak stress is reached. Based on a literature review and an experimental study, Copier (1979) concluded that compressive stresses in the outer layer of a cross-section can give rise to spalling but he considered it unlikely that this could explain the most serious form of spalling. However, Bazant (2005) concluded that the main reason for spalling is a “brittle fracture and delamination buckling caused by compressive biaxial thermal stresses parallel to the heated surface”. A similar explanation was given by Preston and White (1934) when describing the mechanism of spalling in heated clay. As shown in Figure 10, the starting point of spalling in clay is hypothesised to be a initial flaw, lamination or weakness in the material.

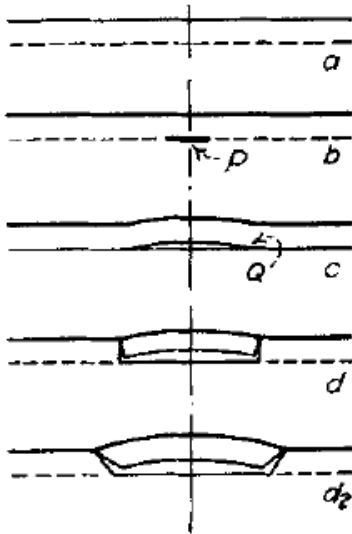

Figure 10 Mechanism of thermal spalling during sudden heating of clay reproduced from Preston and White (1934). The dotted line is the heat wave and point P is a initial flaw, lamination or weakness in the material. The behaviour in d_2 is more probable than d.

Even Hasenjäger (1935) suggested the exceeding of the tensile strength by one sided strain as a plausible explanation for spalling. According to Bazant (2005), the development of high pore pressure may only serve as a trigger for spalling, not the main driving force. The reason for this conclusion was that pore pressures high enough to trigger spalling have never been recorded experimentally. If a crack were to be opened by pore pressure, the available volume for the water would immediately rise by several orders of magnitude. In this situation, when additional water cannot flow into the crack at once, the pore pressure must drop to close to zero. During an experimental study, Arita et al. (2002) recorded the sound of internal cracking before spalling occurred (no cracks were seen on the surface). The conclusion from this experimental series and a numerical analysis was that the spalling process starts with cracks parallel to the surface layer followed by surface buckling leading to spalling. The numerical simulation of the heat and mass transfer and stresses during the experiments showed only small pore pressures compared with the thermal stresses.

A mix of **Thermal and Moisture Induced Stresses** has been proposed as the reason for spalling by Zhukov (1976). He describes the spalling process as the development of an unstable crack inside the concrete, that develops up to the surface of the specimen. The crack growth is ascribed to internal compressive stresses, compressive stresses caused by external load, and tension stresses caused by steam generation. The cumulative process leading to spalling is illustrated in Figure 11. Note in the figure that the region where the crack is initiated is where the compressive stresses from thermal expansion and external load are vertical while tension stresses are horizontal.

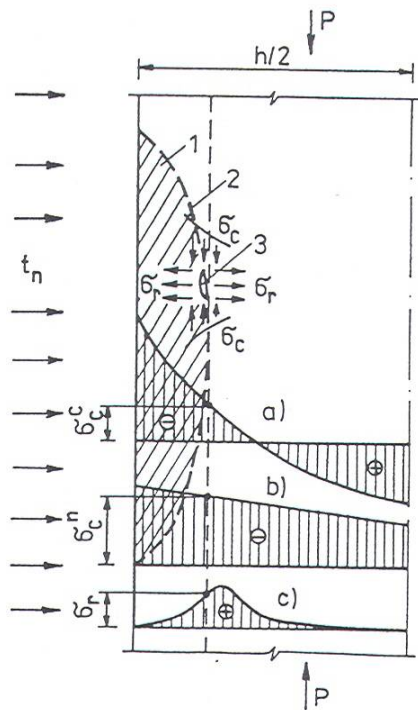

Figure 11 Development of an unstable crack leading to fire spalling, reproduced from Zhukov (1976). Notation: a) internal stresses, b) external load stresses, c) steam generated stresses, 1- piece of spalled concrete, 2 - trajectory of the crack development, 3 - crack.

There are a number of sophisticated numerical models which aim to describe the mechanisms leading to fire spalling of concrete. A research team in Italy has worked intensely with a hygro-thermo-chemo-mechanical model called the “Padua” model, Gawin et al. (2006). This volume averaging numerical model, along with others of the same type, Tenchev et al. (2001), Shamalta et al. (2005), aim at predicting the occurrence of spalling. The models are generally based on thermodynamically reasonable principles but are still on highly fundamental level, i.e., in their present state the numerical models cannot provide a reliable substitute to fire testing for the determination or prediction of fire spalling of concrete.

2.3 Summary

The theoretical explanations for spalling described above overlap to a significant degree. Almost all theories contain some reference to the importance of moisture as either the driving force for spalling or one of several driving forces. The main theories are:

- Moisture Clog Theory
- Hydraulic Spalling Theory
- Frictional Forces Theory
- Thermal Stresses
- Thermal and Moisture Induces Stresses Theory

None of these theories fully explain spalling in all situations. Indeed, as discussed in Article III, several of these theories probably interact to cause spalling. Most significant, however, is that all theories have been developed based on an understanding of underlying transport phenomena but are very difficult to confirm experimentally as they require the measurement of physical properties or transient phenomena that are often affected by intrusive measurement techniques.

The next chapter deals with a variety of experimental investigations that have been conducted to characterise the spalling behaviour of different types of concrete and experimental investigations that aim to measure underlying physical parameters or transient phenomena in an effort to confirm or refute some of the various theories that have been presented above.

3 Experimental study

The various theories explained in the previous chapter lack experimental validation. It is not possible to determine which of the proposed mechanisms, or combinations thereof, are correct without such experimental support. In the work presented in this thesis a number of different experimental techniques or combinations of techniques have been used to investigate the validity of the various theories. These experimental techniques and some results are described below.

3.1 Capillary saturation

The degree of capillary saturation at room temperature, i.e., the proportion of the capillaries that is initially filled with water, is a factor that influences moisture transport. Further, the evolution of pore pressure during fire exposure is naturally linked with the initial degree of capillary saturation, Connolly (1995).

Concrete filled plastic pipes were used to represent the two sided drying of large slabs used in the spalling tests described in Article IV. The aim was to investigate whether differences in capillary saturation could give any clue to how PP- fibres can reduce spalling. The plastic tubes were 300 mm long, had a diameter of 45 mm and were open at both ends. They were stored under the same conditions as the large specimens that they represented. Close to the day of the fire test of the large specimens, the cylinders inside the plastic tubes were sliced into 2 cm thick slices, to determine the capillary saturation profiles. The thickness of 2 cm was chosen as this was the smallest size possible with the slicing method chosen. To minimize the heating of the specimen during slicing, the specimen was first notched a couple of mm with a diamond disc, see Figure 12, and then cut using an axe, see Figure 13.



Figure 12 The author is notching of the specimens.



Figure 13 The author is slicing of the specimens where the notch is.

The sliced test specimens were then used to determine of the degree of capillary saturation according to the method described by Hedenblad and Nilsson (1985). The specimen was first weighed, then the underside of the specimen was placed in contact with a water surface and evaporation protection was attached to the top of the sample before capillary suction began. The specimen was kept in contact with the water surface until it was capillary saturated, i.e. when no change in weight over time could be seen. At this point the weight was recorded and the specimen was dried at 105 °C. The degree of capillary saturation was then determined using the following formula:

$$S_{cap} = \frac{m_w - m_0}{m_{cap} - m_0}$$

S_{cap} = the degree of capillary saturation

m_w = the mass of the sample in the moist state (initial state)

m_{cap} = the mass of the sample after capillary suction

m_0 = the mass of the sample in the dry state

In Article IV it was concluded that PP-fibres in concrete modify the degree of capillary saturation, see Figure 14. The results of the degree of capillary saturation measurements indicate that the specimens containing PP-fibres show a higher degree of capillary saturation close to the surface to be fire tested (0-20 mm). It can also be seen that close to the surface to be fire tested, the sequence from lowest to highest degree of capillary saturation is the same for those concrete types with maximum aggregate size 16 mm as for those with maximum size 25 mm. In both cases the order from lowest to highest is: concrete without PP-fibres, 1 kg 32 µm PP-fibres, 1 kg 18 µm PP-fibres and 1.5 kg 18 µm PP-fibres. Almost the same order from lowest to highest was also seen when determination of the average moisture content in cubes, 150 × 150 mm², was performed, shown in Table 3. To summarise, the results from this limited study indicated that PP-fibres restricted drying. There is no obvious connection between this results and the anti-spalling function of PP- fibres.

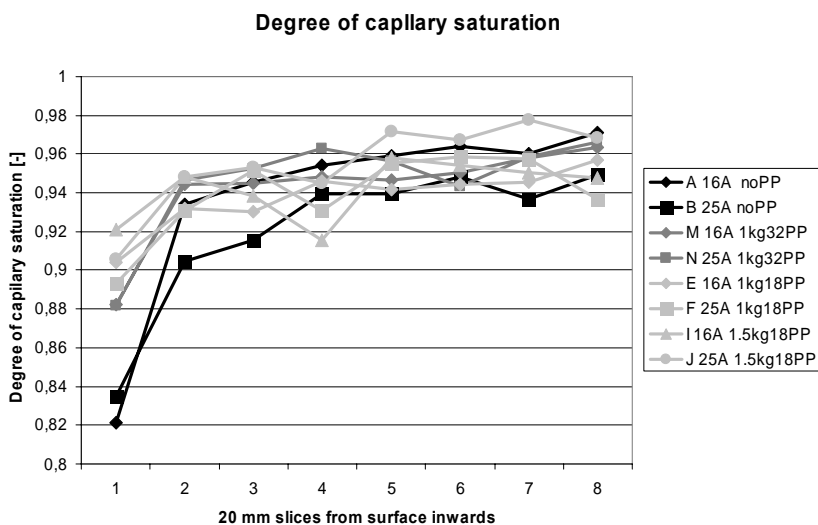

Figure 14 Results from capillary saturation tests. A description of the tested concretes and storage conditions can be seen in Article IV.

Table 3 Average moisture content (% by dry weight) in cubes ($150 \times 150 \text{ mm}^2$).

Max aggregate size 16 mm	Moisture content in cubes [%]	Max aggregate size 25 mm	Moisture content in cubes [%]
A	5.1	B	5.2
M (1 kg 32 μm PP-fibres)	5.8	N (1 kg 32 μm PP-fibres)	4.9
E (1 kg 18 μm PP-fibres)	6.1	F (1 kg 18 μm PP-fibres)	5.4
I (1.5 kg 18 μm PP-fibres)	5.8	J (1.5 kg 18 μm PP-fibres)	6.0

3.2 Fire resistance testing

3.2.1 Small furnace tests

As shown in Article IV of this thesis some of the spalling tests were performed using a small furnace. The furnace had inner dimensions of $500 \times 400 \times 525 \text{ mm}^3$ with an opening of $500 \times 400 \text{ mm}^2$ on the top of the furnace. The specimens to be tested covered the opening, i.e. the fire exposure was one-sided only (from below the test specimen).

When testing according to the European standard, EN 1363-1, the furnace temperature is measured using plate thermometers. The use of plate thermometers in furnace testing has revolutionised such testing relative to the use of traditional shielded thermocouples. This has led to smaller differences in fire exposure from different furnaces, i.e. the time a construction can survive a fire is less dependent of the furnace that is used.

In the small scale furnace used in this project, it was not possible to include a plate thermometer in the actual tests due to the shadow effect of the plate on the specimen. This is not important in a large furnace test but in the small furnace when the exposed surface

is $500 \times 400 \text{ mm}^2$ and the plate thermometer is $100 \times 100 \text{ mm}^2$, the shadow effect is significant. However, in an attempt to adjust the thermal exposure to a standard fire test (EN 1363-1) the furnace was calibrated using a plate thermometer and a “standard” concrete test sample. The calibration was performed by regulating the furnace according to a plate thermometer and simultaneously measuring the temperature with a 1 mm shielded type K thermocouple, see Figure 15.

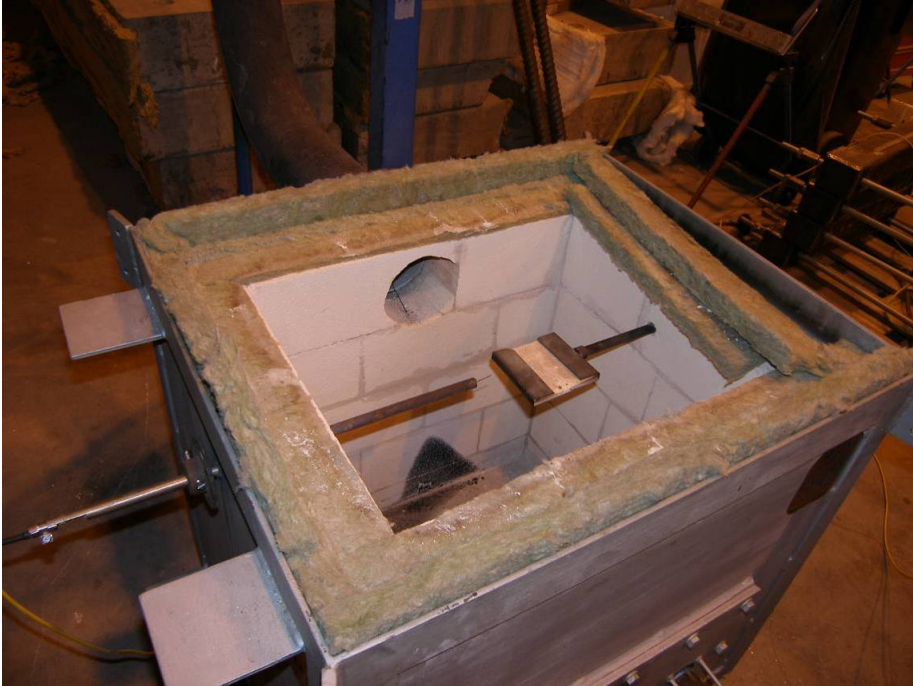

Figure 15 Comparison test between a 1 mm shielded typ K thermocouple and a plate thermometer.

The difference in temperature readings between the two temperature measurement devices is shown in Figure 16.

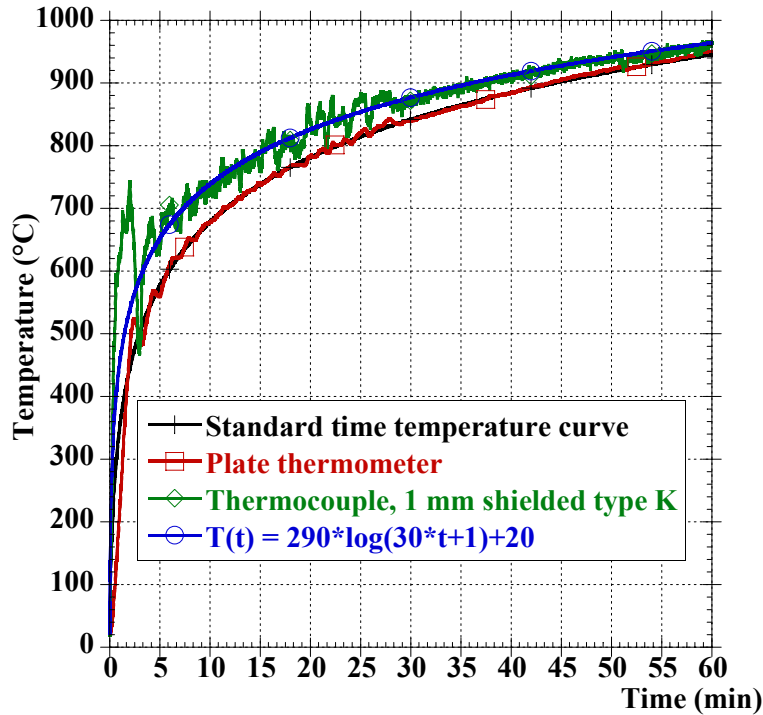

Figure 16: Temperatures measured in the small furnace during calibration using different measurement devices.

Based on the results of the calibration, a specific fire curve was devised for the small furnace used in this work using a 1 mm shielded thermocouple to control the furnace. One should note that this curve is specific to this furnace configuration and cannot be generalised to other furnaces (even if they are the same size) without re-calibration. The fire curve for the small furnace, based on a 1 mm shielded thermocouple, was fitted to the following curve:

$$T(t) = 290 \times \log(30 \times t + 1) + 20 \quad [^{\circ}\text{C}]$$

T = temperature

t = time in minutes

The temperature was also measured inside the test specimens during the fire tests. This was accomplished using thermocouples with a welded tip as the measuring point. The thermocouples were placed in the concrete during moulding at a distance of 10 mm and 40 mm from the surface exposed to the fire.

All tests were performed on specimens loaded in compression. The load level was 10 % of the cube compressive strength as tested prior to the fire test. Post-stressing was performed using four Dywidag bars, thickness 28 mm, inserted into the concrete. The applied load was monitored using four load cells, two on each side of the specimen. The loading system is shown in Figure 17.

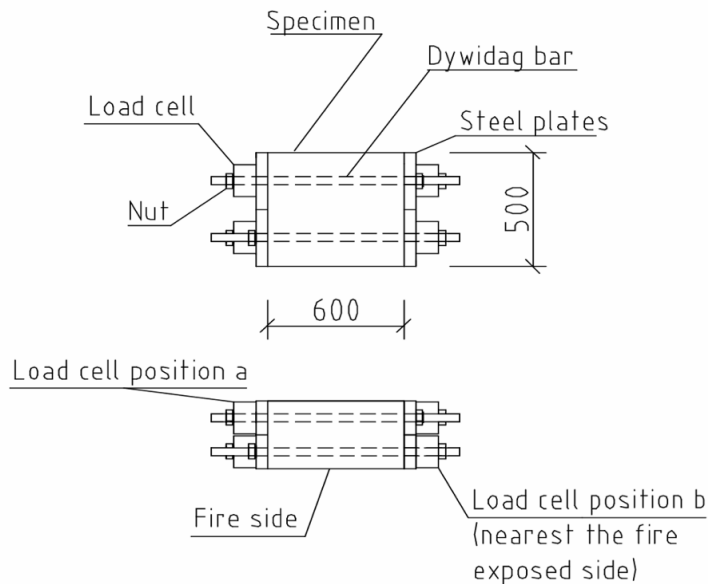

Figure 17 The loading system for small slabs.

The tensile stress in the bars was measured with load cells connected to an MGC Plus system and a computer for data collection.

If the results from these tests are compared with the results from the large scale test using standard fire exposure (EN 1363-1), it can be seen that the spalling is generally less severe on the small furnace. The reason for the difference is believed to be the significantly greater boundary effects on small specimens during the later stages of fire exposure. These boundary effects are probably negligible during the early stages of the exposure. Some proof of this can be seen when comparing the times when spalling starts during the two tests using small slabs of concrete A and the single test using a large slab of concrete A as described in Article IV. During the two small scale tests spalling starts after 7.75 minutes and 8.47 minutes which shall be compared with the spalling start 8 minutes during the test on the large slab. When the spalling then continues to a certain depth the boundary effects will be different for the large scale test relative to the small scale test. To summarise, small slabs in the used experimental setup can be used *both* to conduct an investigation of the risk for explosive spalling during one dimensional fire exposure, and to provide an indication of whether it is necessary to investigate the spalling depth in a larger slab to verify large scale performance.

3.2.2 Large furnace tests

The furnace used in the large slab test series, described in Article IV, had inner dimensions of $5 \times 3 \times 2 \text{ m}^3$ with a horizontal opening at the top of the furnace of $5 \times 3 \text{ m}^2$. The specimens to be tested, with the dimensions $1200 \times 1700 \times 300 \text{ mm}^3$, covered the opening, i.e. the fire exposure was one sided only, from below. The large slabs were tested in two separate furnace runs, one with the RWS fire exposure and one with the standard fire exposure specified in the European standard EN 1363-1 (1999), see Figure 18.

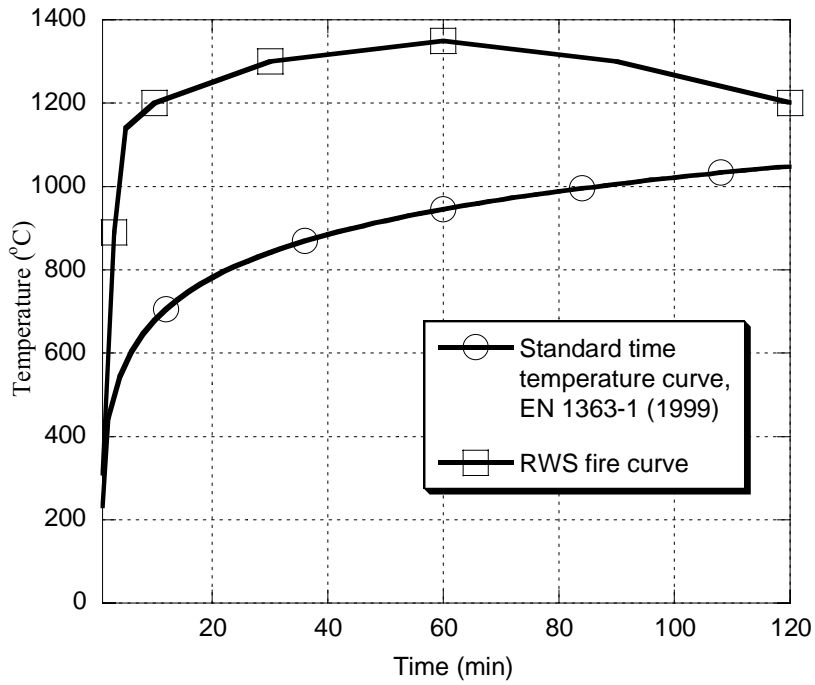

Figure 18 Temperature curves used for fire testing.

The location of the test specimens on the furnace in the two tests is shown in Figure 19 and Figure 20. The specimens were connected two-by-two, with the internal loading system described below, i.e., in Figure 19, A and B, E and F etc. are connected.

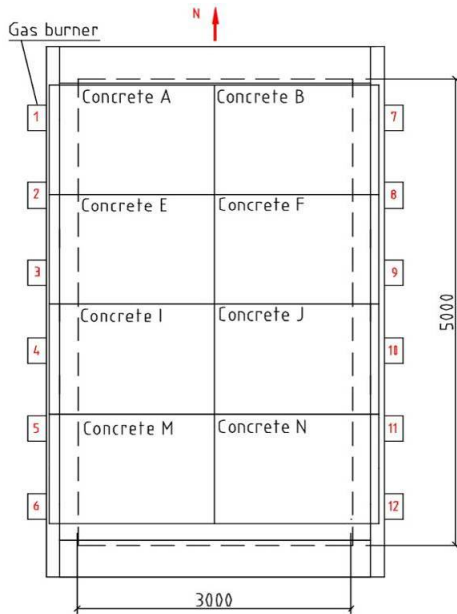

Figure 19 The location of test specimen during the RWS test as seen from above.

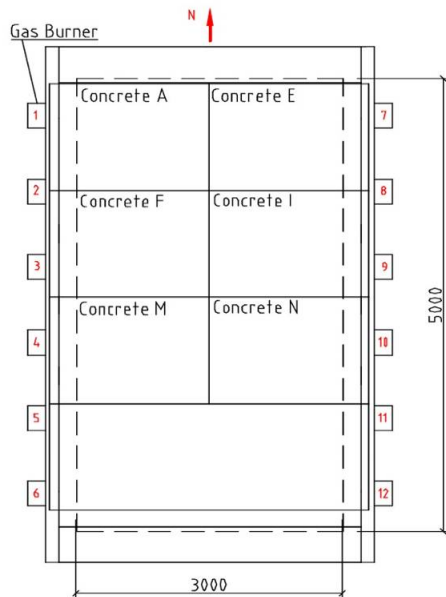

Figure 20: The location of test specimen during the EN 1363-1 test as seen from above.

The load was close to 10 % of the cube compressive strength of that concrete with the lowest strength in the pair. Post-stressing was performed using eight Dywidag bars with a diameter of 28 mm, inserted into the concrete. The applied load was monitored using four load cells during the fire test. A drawing of the loading system is shown in Figure 21. Figure 22 shows a photo of the loading system during a fire test. Some results from the large scale tests described in Article IV can be seen in Figure 4. The results show that PP-fibres reduce fire spalling.

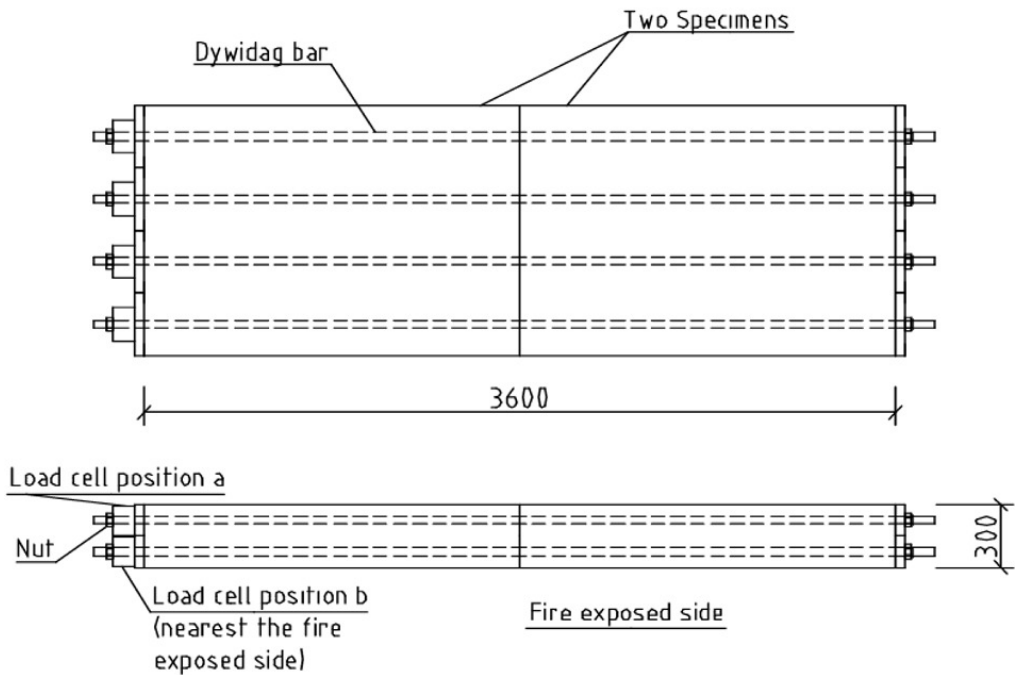

Figure 21: Loading system for a pair of large test specimens.



Figure 22: The loading system on the side without load cells during fire test.

3.3 Moisture pressure measurements

In the experiments described in articles II and III, indirect measurements of the moisture pressure during fire exposure were performed. The pressure cannot be strictly defined as a vapour pressure in all situations because at a certain depth the crack and capillary pore system may be fully saturated. If this is the case, the pressure measured with the system used will be a liquid pressure. An experimental indication of the presence of a fully saturated zone is that liquid water is literally pouring out of the non-fire-exposed side when a concrete cross-section is fire tested from one side.

In the approach used in this thesis, the pressure is conducted out of the specimen in a small pipe so that the pressure can be measured outside of the sample. This is a more cost effective method than embedded sensors because the pressure sensor can be reused and the working conditions for the sensor are more stable. The actual measurement in a pipe system can be conducted either as a vapour pressure measurement, using an empty pipe as performed by Kalifa et al. (2000) and Kusterle et al. (2004), or as a fluid pressure measurement, using oil as the pressure conductor, as performed by Harada and Terai (1997). Oil was used in the pipe during the present experiments to limit the compressible volume that is always present in an air filled system.

During casting of the concrete specimens, thin steel pipes, with an inner diameter of 2 mm and wall thickness of 0.2 mm, were inserted into the concrete. One end of each steel pipe was placed at different depths from the surface to be fire tested. The pipe extended from the measurement point through the test specimen, exiting on the cold side. To ensure that no concrete, i.e. cement paste, would fill the pipes, thin welding bars were inserted into the pipes during casting.

When the fire tests were conducted, the welding bars inside the steel pipes were removed and the pipes were filled with high temperature resistant silicone oil, Sil 300, produced by Haake. The filling of the pipes was conducted by inserting a thin needle and syringe and carefully injecting oil from the bottom of the pipe to ensure that no air was trapped. Outside the concrete, the steel pipes were connected to a pressure gauge using a T-junction. The pressure gauges that were used were of the type P8AP/100bar from Hottinger Baldwin Messtechnik GmbH. A photo of the pressure gauges and the T-junctions are shown in Figure 23.

This method was devised to measure the internal pressure in the concrete prior to spalling in an effort to confirm or refute the Moisture Clog Theory. In Articles II and III in this thesis, it was concluded that the pore pressure played only a secondary role in the spalling process of the investigated self compacting concrete, because the maximum pressure was fairly low.

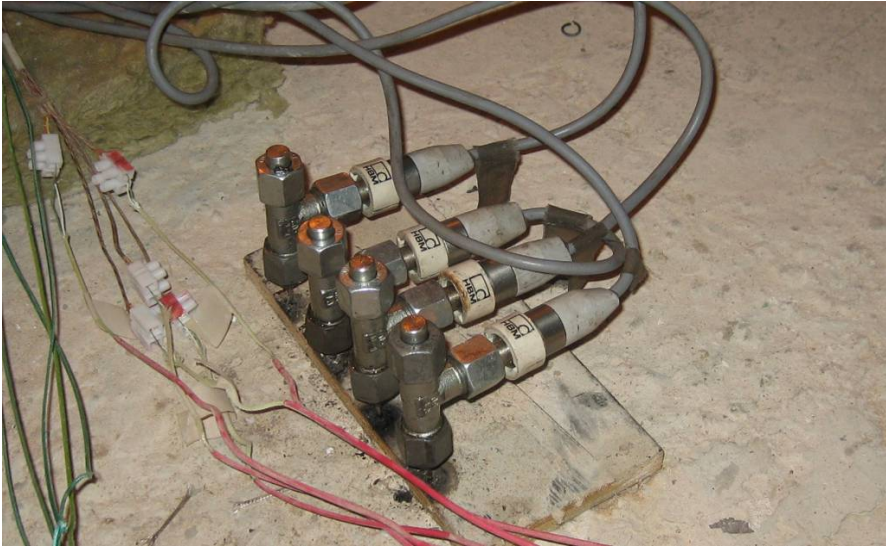

Figure 23 The pressure gauges and the T-junctions used in the pressure measurement system.

3.4 Thermal characteristics of concrete

The Transient Plane Source (TPS) method is a transient method for the determination of the thermal conductivity, thermal diffusivity and specific heat, simultaneously. The method was developed by Gustafsson (1991) at the Chalmers University of Technology in Sweden.

When a measurement according to the basic TPS method is performed, a flat round hot disc sensor is placed between two “slices” of a specific material, see Figure 24. The sensor consists of a thin nickel foil spiral, 10 μm , which is sandwiched between two sheets of electrical insulation material.

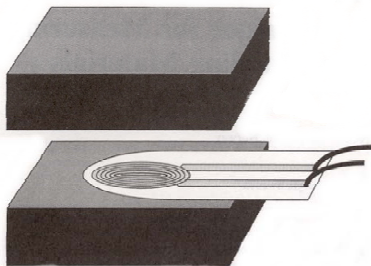

Figure 24 Test setup for a measurement according to the TPS method, Gustafsson and Long (1995)

The hot disc sensor acts as a constant effect generator and a resistance thermometer at the same time. The measurement starts when a stepwise power pulse is applied to the sensor. When a constant electrical effect is applied, the temperature in the sensor rises and heat starts to flow to the tested material. The time dependent resistance rise is then recorded

and converted using the temperature coefficient for the resistivity of Nickel, to a temperature response curve, see Figure 25.

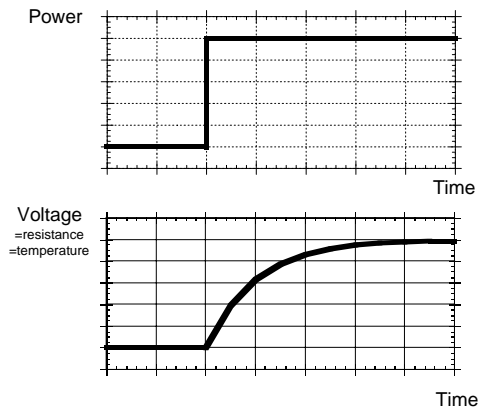

Figure 25 When the stepwise power pulse is applied the change in voltage is recorded and converted to resistance and thereafter temperature

The temperature rise in the sensor is a direct response to the thermal properties of the tested material. If the material has good insulation properties, i.e., low conductivity and diffusivity, the temperature of the sensor will rise rapidly when a given amount of heating effect is applied. If, on the other hand, the material has good conducting properties the applied heat will be transported faster inside the material and the temperature will not rise as rapidly as in the test of the insulating material. The separation of thermal diffusivity and thermal conductivity in a measurement is conducted using a calculation software. The calculation is based on the principle that the early part of the heating is similar to heating of an infinite slab, i.e. one dimensional, while the latter part of the heating is close to a point source, i.e. three dimensional. Once the thermal diffusivity and thermal conductivity are known, the volumetric specific heat can be calculated.

When measurements are made using the TPS method, the test specimen must have a uniform internal temperature distribution. A temperature drift recording, which is the start-up for every measurement, is used to confirm this. If the temperature recording shows a systematic drift in any direction, the possibility exists to compensate for this in the software, although the accuracy of the measurement may be reduced considerably and it is not recommended. The measurements at high temperatures shown in Article I in this thesis have been performed inside a muffle furnace.

One limitation of this method is that it is not possible to measure phase transitions. For material like concrete, the fundamental specific heat is not sufficient to describe the amount of energy that is needed to heat a piece of the material due to the fact that the material undergoes chemical reactions and conversions during heating. Despite this limitation the methodology seems promising even for use in materials like concrete provided the effect of evaporation of water or other phase transitions at very high fire temperatures, for example the melting of concrete, is added when doing a temperature calculation based on measured thermal data. An example of this type of calculation is given in Article I.

When the energy needed for reactions and conversions is included in the specific heat, it is usually referred to as the “apparent specific heat”, Harmathy (1993), Bazant & Kaplan,

1996), Schneider & Horvat (2003). The “apparent” specific heat is shown in equation 3.1 below.

$$c_p = \left(\frac{\partial H}{\partial T} \right)_p + \Delta H_r \left(\frac{\partial \xi}{\partial T} \right)_{p,T} \quad (3.1)$$

The first term is the sensitive heat contribution to the specific heat (i.e., the fundamental specific heat as defined by thermodynamics) and the second term is the contribution from chemical reactions. The second term can be a sum of different chemical processes or phase changes which occur in the concrete. In this case, ΔH_r is the enthalpy change for each elementary reaction, and ξ is the reaction progress variable ($0 < \xi < 1$). Thus, the term $\frac{\partial \xi}{\partial T}$ provides information concerning how the reaction has progressed during any given temperature change. Several processes can occur in the same temperature interval.

Examples of reactions that can be included in the “apparent specific heat” can be seen in **Fel! Hittar inte referenskölla.**, Schneider & Diederichs (1981). Note that the concrete, in the example shown, includes quartzite or limestone aggregate and blast furnace slag cement.

Table 4 Examples of reactions in a concrete during heating, Schneider & Diederichs (1981).

<i>Temperature (°C)</i>	<i>Transformation or decomposition reaction</i>	<i>Heat of transformation or decomposition per unit mass (kJ/kg)</i>	<i>Mass of material transformed or decomposed per m³ of concrete (kg/m³)</i>	<i>Heat of transformation or decomposition per m³ of concrete (kJ/m³)</i>
30-120	Release of evaporable water	Heat of evaporation of water, 2238 kJ/kg (endothermic reaction)	130 kg water	290 MJ
30-300	Dehydration of non-evaporable or chemically bound water in cement gel	Heat of hydration of β -C ₂ S, 250 kJ/kg (endothermic reaction)	78 kg hardened cement paste	20 MJ
120-600	Release of remainder of evaporable and non-evaporable water	Heat of hydration not less than 2238 kJ/kg (endothermic reaction)	About 60 kg water	135 MJ
450-550	Decomposition of Ca(OH) ₂ = CaO + H ₂ O	Heat of decomposition of Ca(OH) ₂ , 1000 kJ/kg (endothermic reaction)	Not more than 40 kg Ca(OH) ₂	40 MJ
570	Transformation of α - to β -quartz	Heat of transformation of SiO ₂ , 5.9 kJ/kg (endothermic reaction)	1500 kg SiO ₂ in quartzite concrete, 200 kg SiO ₂ in limestone concrete	8.8 MJ, 1.2 MJ
600-700	Decomposition of CSH and formation of β -C ₂ S	Heat of decomposition 500 kJ/kg (endothermic reaction)	240 kg C ₂ S in hardened cement paste	120 MJ
780	Recrystallisation of unhydrated cement	Heat of recrystallization, 50 kJ/kg (exothermic reaction)	100 kg unhydrated blast furnace slag cement	5 MJ

600-900	Decarbonation of limestone aggregate	Heat of decomposition, 1637 kJ/kg (endothermic reaction)	1440 kg CaCO ₃	2360 MJ
1100-1200	Melting of concrete	Heat of melting, 750 kJ/kg (endothermic reaction)	2100 kg quartzite concrete, 1500 kg limestone concrete	1575 MJ, 1125 MJ

An example, found in Article I, of results from measurements of the thermal conductivity with the TPS method is shown in Figure 26. The test was performed on pre-dried specimens, dried at 105°C. The thermal cycle starts with the highest value at 20°C and then decreasing with increasing temperature. Measurements performed during the cooling down cycle shows an almost constant value.

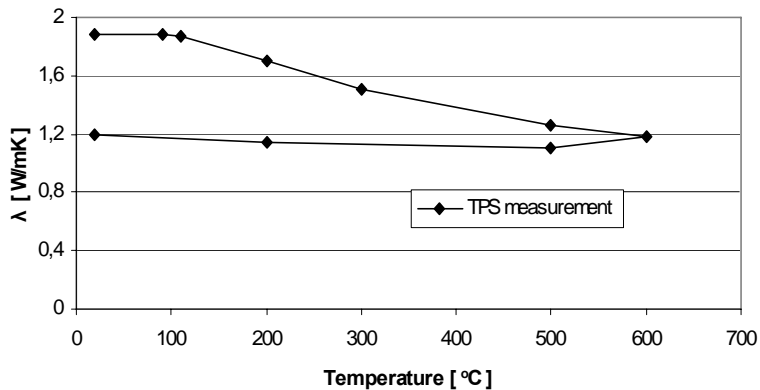

Figure 26 The thermal conductivity for the tested concrete at different temperatures and place in the heating cycle. The heating cycle starts at the highest conductivity value at 20°C.

To determine whether the thermal properties measured with the TPS method were relevant, a temperature calculation using the TPS data was compared with the temperatures measured during a fire test. The boundary conditions in the calculation were the temperature measured at the depth of 10 mm from the surface while those at the depths of 25 mm and 50 mm from the surface were used for comparisons between the calculated values and temperature measurements. The results, shown in Figure 27, show a good correlation between measured and calculated temperatures. More details concerning the calculations can be found in Article I.

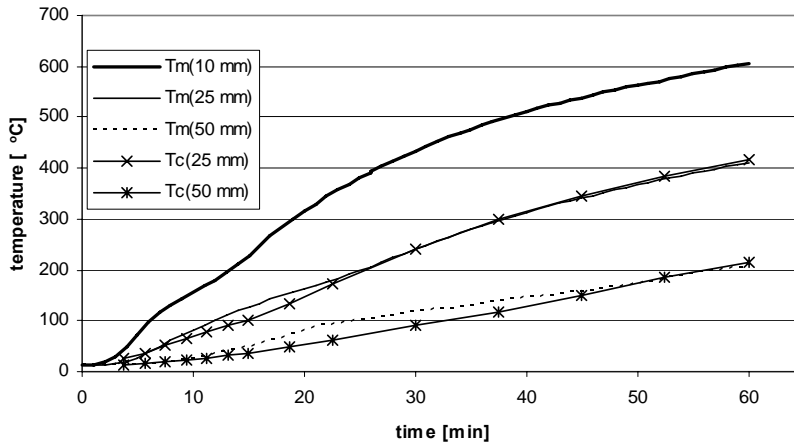

Figure 27 Temperature curves at different depths. Tm is measured temperature and Tc is the calculated temperature.

3.5 Drying tests

Transient drying tests were performed in an electrical tube furnace as shown in Figure 28. When performing a test, the specimen is hung on a wire attached to a balance. The balance is connected to a computer for data collection.

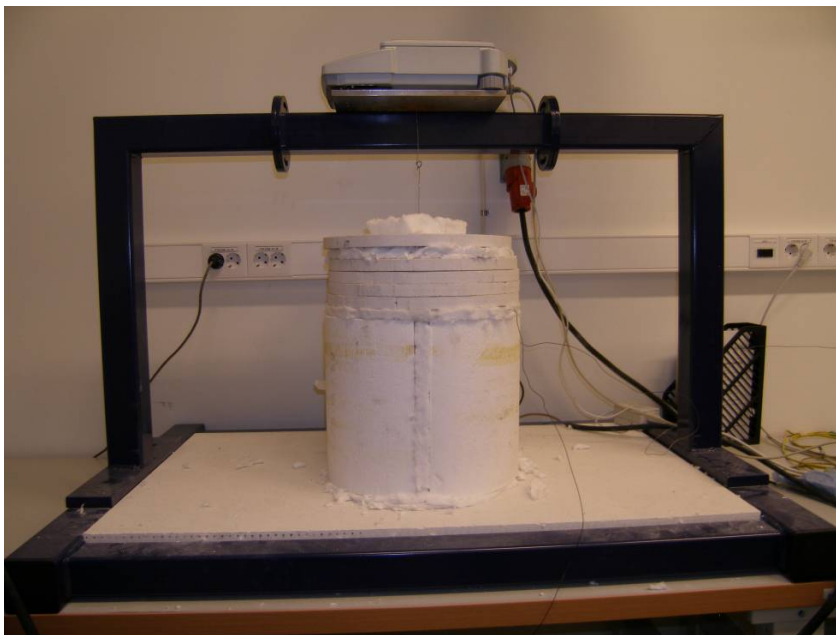

Figure 28 Balance and furnace used to measure transient drying.

The electrical effect to the tube furnace is automatically adjusted to obtain a ramp temperature function. This is recorded using a thermocouple placed a few mm from the middle of the test specimen. With this arrangement the actual surface temperature is not measured but as most of the experiments are of comparative nature this is a minor problem.

Results from the weight loss measurements, during exposure to a heating ramp of $2^{\circ}\text{C}/\text{minute}$, are shown in Figure 29. As seen in the figure the weight loss before reaching 100°C (a few mm from the middle of the test specimen) is limited. This is due to the thermal inertia of the material, i.e. the inner core is colder than the heated exterior, and low permeability of the sample leading to restricted moisture flow. The derivatives of these curves can be seen in Figure 37 in the discussion chapter.

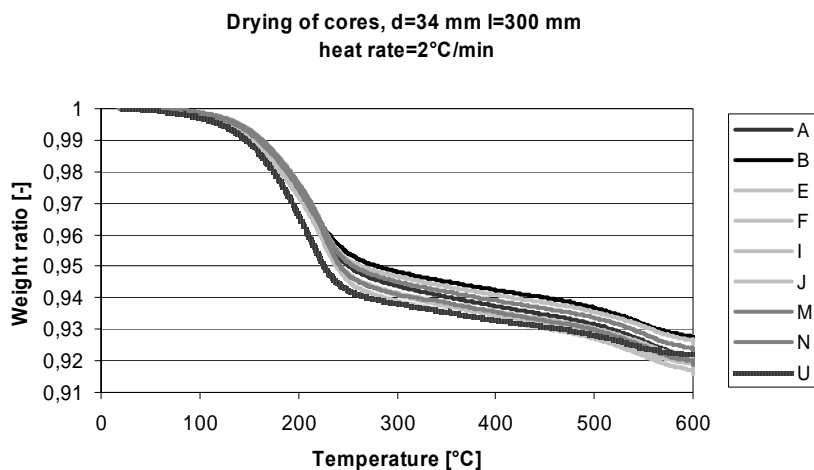

Figure 29 The weight loss of 34 mm cores at the heating rate of 2°C/minute normalised relative to the original weight.

3.6 Permeability

The Cembureau method was used to measure the gas permeability both before and after heating (residual testing). Nitrogen gas was used with a differential pressure of 0.2 MPa and the intrinsic permeability was calculated according the following formula, Neville (1996):

$$K = \frac{2qp_0L\eta}{A(p^2 - p_a^2)}$$

K = intrinsic permeability coefficient [m^2]

q = volume flow [m^3/s]

p_o = pressure at which the volume flow rate is measured [Pa]

L = thickness of specimen[m]

η = dynamic viscosity [Ns/m^2] (nitrogen = 1.76×10^{-5})

A = cross-sectional are of the specimen [m^2]

p = inlet pressure [Pa]

p_a = outlet pressure [Pa]

The only inlet pressure used was 0.2 MPa, so no estimation of the Klinkenberg effect (so called “slip flow”) could be made. The Klinkenberg effect was not explored as these tests were conducted mainly to provide comparative data between the different types of concrete studied.

The specimens used in the tests were cylinders, diameter 150 mm and height 48 mm, sawed from cores a couple of days after casting. After sawing, both cut surfaces were ground smooth using a diamond grinder. The specimens were then wiped clean from all free moisture and put inside plastic bags until tested.



Figure 30 The Cembureau test equipment for measurement of gas permeability.

In Article IV an investigation of the influence of the heating scenario on the *apparent* residual permeability was performed. The results from this type of permeability experiment after rapid heat exposure from all sides should not be seen as intrinsic material data, as there will not be a uniform crack pattern produced throughout the specimen. This method gives, therefore, only an indication of the effect of heating on the apparent permeability, not a measure of the absolute permeability of the sample. This means that the results provide information concerning an increase in the presence of cracks, but not of their distribution in the sample.

Heating of test specimens to 400 °C with different heating rates does not influence the residual permeability, i.e. the ratio of the permeability from the specimen heated with a thermal shock to that of a sample heated at a rate of 1 °C per minute, does not vary significantly when comparing before heating and after heating. When the same experiment was repeated using the oven pre-heated to 600 °C, however, the specimen exposed to thermal shock exhibits more cracks than the specimen heated slowly. The specimen exposed to a thermal shock has twice the residual permeability as the specimen that has been heated slowly. Cracks close to the edges could be seen on the specimen exposed to thermal shock. This is probably the reason why pore pressure measurements on slowly heated specimens are often higher than fire exposed specimens. This also indicates that the mechanical properties close to the surface where spalling occurs are not easily examined with traditional slow heating methods. The depth of the surface cracking that was indicated by the permeability test was not investigated in this project but could be further analysed using microscopy.

3.7 Speed of sound

The speed of sound is related to the dynamic elastic modulus of the material, i.e., the speed of sound is higher in a stiffer material. The elastic modulus for concrete decreases almost linearly from room temperature to between 800 °C to 1000 °C, when it is almost zero according to Eurocode 2 (2004). This is a measure of internal cracking.

The cylindrical test specimens used in the drying tests were also tested in a speed of sound apparatus, see Figure 31 and Figure 32. When conducting these experiments, a contact gel is put on the sensors and the apparatus is calibrated against a reference material with a known speed of sound.

The speed of sound was tested before heating the specimen during the drying test and directly after cooling down to room temperature. Results, further described in Article IV, show that concrete with PP- fibres exhibits a smaller loss of elastic modulus after heating to 600 °C with a heating rate of 5 °C/minute than concrete without PP-fibres. An example of the results from these measurements is shown in Figure 33. This figure is reproduced from Article IV and shows the difference in speed of sound between specimens with and without PP- fibres. In specimens without PP- fibres, the reduction in the speed of sound is larger than in specimens with PP-fibres.



Figure 31 The contact gel, reference material and speed of sound apparatus.



Figure 32 The speed of sound sensors.

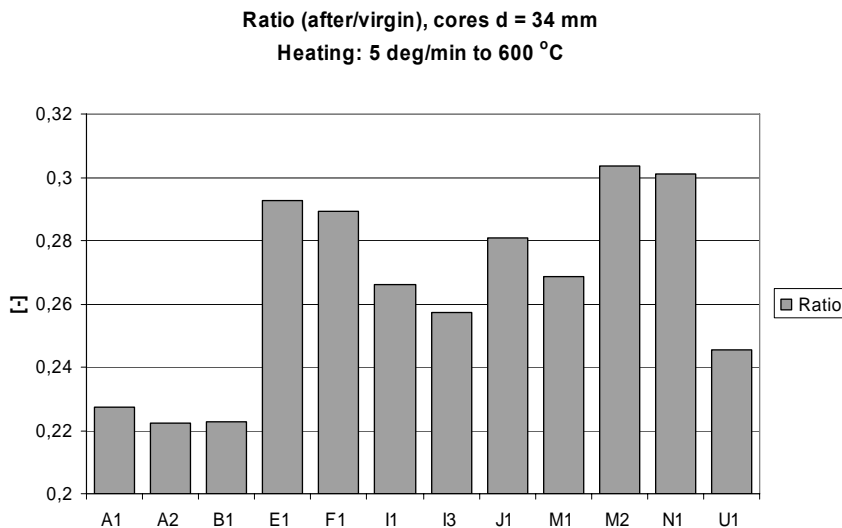

Figure 33 Speed of sound ratio (after/virgin), cores d=34 mm, heating: 5 °/min up to 600 °C. Specimen A and B and U do not contain PP- fibres. U is a reference concrete with higher w/c ratio.

3.8 Thermal expansion

As shown in Article IV tests of the free thermal expansion of concrete types A, E and I were performed at Centre Scientifique et Technique du Bâtiment (CSTB) in France. The equipment used is built to fulfil the requirements outlined in the RILEM TC 129 MHT “Test methods for mechanical properties of concrete at high temperatures- Part 6: Thermal strain”, (1997). The thermal expansion was measured on cylinders with a diameter of 104 mm and length 300 mm. The cylinders were placed in a cylindrical furnace and a strain measurement system was attached. Both the longitudinal and radial

expansion were measured, each with three strain gauges. The heating rate was 1°C/minute up to the maximum temperature of 600°C. The measurement system, shown in Figure 34, is described in more detail by Hager (2004).



Figure 34 The equipment for measurements of mechanical properties at high temperature at CSTB in France.

Test results from the thermal expansion measurements on concrete types A, E and I show, when looking at the whole temperature scale, quite similar results for the different concretes. This is expected because the only difference between the concretes is the amount of PP-fibres added and the major driving force for expansion is the aggregate which is the same in all mixes.

There is one interesting difference although it is small. At around 200-250°C the thermal expansion decreases to zero or close to zero for concretes E and I. After this decrease there is an increased expansion rate between 250-300 °C compared to concrete A, so at 300°C the total strain is almost the same as before the strain plateau. Concrete A is free from PP-fibres while concrete E contains 1 kg/m³ 18 µm PP-fibres and I includes 1.5 kg/m³ 18 µm PP-fibres. Further, the decrease is highest for the highest content of PP-fibres. The behaviour can be seen both in the longitudinal and radial direction of the tested cylinders, as shown in Figure 35 and Figure 36.

Free thermal expansion, longitudinal direction

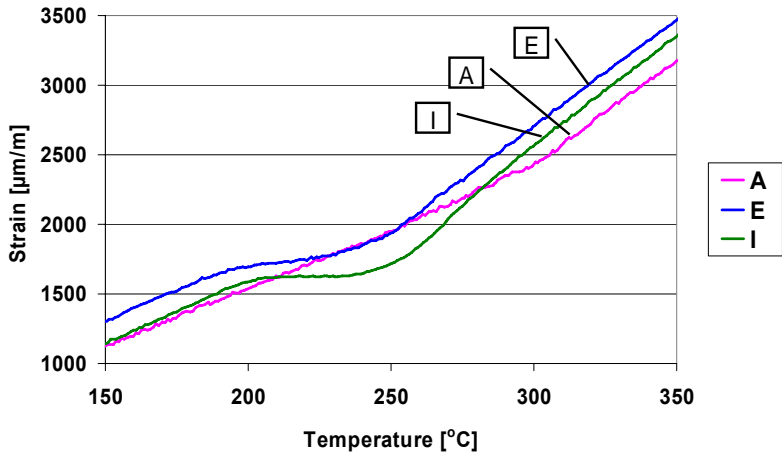

Figure 35 The free thermal expansion in the longitudinal direction, the strain plateau.

Free thermal expansion, radial direction

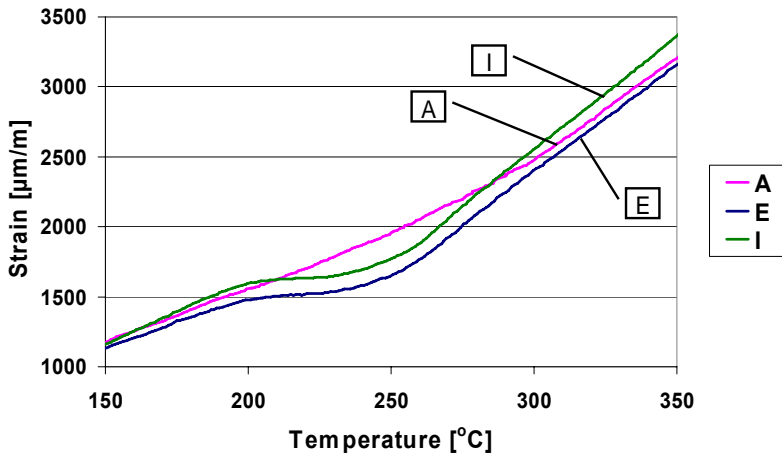

Figure 36 The free thermal expansion in the radial direction, the strain plateau.

4 Resume of articles

4.1 Article I: Measurement of Concrete Thermal Properties at High Temperature

The spread of heat and the shape of the temperature profile in a concrete structure govern all the processes involved in the phenomenon of fire spalling. Therefore, a thorough knowledge of the thermal properties of the material is fundamental to our understanding of fire spalling of concrete.

In this article, the use of the Transient Plane Source (TPS) method to measure the thermal properties at high temperature was investigated. With the TPS method, the thermal conductivity, thermal diffusivity and volumetric specific heat can be determined simultaneously. This is done by applying a heat pulse to the material when the material is in thermal equilibrium. The resulting temperature increase in the sensor gives an indication of the thermal properties of the material and allows the calculation of these properties.

During fire exposure the material is never in thermal equilibrium with the surroundings and the effect of moisture, both by evaporation and transport, on the temperature is always present. Thus, the practical application of the measured properties, requires that the effect of the evaporation and transport of moisture is added to the calculation. This can be done by adding the moisture effect to the specific heat, as described in the Eurocode 2 (2004).

A calculation of the temperature, based on thermal data from TPS experiments, has also been presented in this article. This was found to correspond well with temperatures measured during a large scale fire test on the same type of concrete. This confirms the utility of TPS measurements of the thermal properties of concrete in predicting large scale performance of concrete specimens.

4.2 Article II: Liquid/steam pressure measurement inside concrete exposed to fire

When heating concrete, the moisture in the porous network will expand and evaporate. This will induce pressure in the capillary system. According to Harmathy (1965), the pressure developed is the driving force for the build up of the moisture clog and spalling by internal pressure, as described in more detail in a previous chapter. If the moisture indeed governs the spalling behaviour, it should be possible to confirm this by measuring high pressure inside the concrete immediately prior to spalling.

Using a measurement system consisting of oil filled steel pipes, the pressure inside the concrete during fire exposure, was measured. Results from pressure measurement tests on self compacting concrete show relatively low internal pressure before spalling. In fact, the pressure was highest in a specimen that did not spall during fire exposure. Conclusions from the tests were that pore pressure only played a secondary role in the spalling process of the concrete investigated. Thermal stresses were believed to be the primary reason for spalling.

4.3 Article III: Fire spalling: Theories and experiments

An overview of the most common spalling theories is given in this article. A more detailed overview of the different theories can be seen in chapter 2 of this thesis. The theories illustrated include:

- Moisture Clog,
- Hydraulic theory, and
- Thermal stresses.

One important aspect discussed in this article is the relationship between drying creep and moisture transport. It is clear from the literature that drying creep releases thermal stresses in the material due to expansion. If moisture transport is restricted this reduces the impact of such creep and stresses increase.

It is suggested that this may be the explanation for fire spalling of dense concrete, i.e., that stress relaxing moisture release is restricted.

4.4 Article IV: Experimental study of the influence of polypropylene fibres on material properties and fire spalling of concrete

This article focuses on the effect of polypropylene (PP) fibres in concrete. The influence of PP-fibres on the following was investigated:

- Moisture content and degree of capillary saturation
- Fire spalling, thermal exposure with standard fire or RWS fire
- Drying, an example of drying of 34 mm cores during a temperature rise at 2°C/min was shown
- Speed of sound, the change of speed of sound in 34 mm thick cores after heating to 600°C with the heating rate 5°C/min
- Free thermal strain during heating of 100 mm thick cylinders with a temperature rise of 1°C/min

Tests to determine the role of the heating rate on the residual permeability of a concrete without PP-fibres were also performed.

Results from the study shows that PP-fibres:

- reduce or prevent fire spalling
- modify the capillary saturation close to the surface of concrete
- limit the internal destruction at moderate heating, 5°C per minute
- modify the drying behaviour at high temperature
- introduce a plateau in the free thermal strain curve.

It was also found that concrete without PP-fibres heated by a thermal shock to 600°C had twice the residual permeability of concrete heated at a heating rate of 1°C per minute to the same target temperature. The same test performed with a target temperature of 400°C did not reveal any measurable difference. The influence of cracking during fast temperature rise was illustrated in this manner.

5 Discussion

Concrete with a small addition of PP-fibres is less sensitive to fire spalling, and the probability of fire spalling is reduced. This is a well known fact in the research community which is illustrated in Article IV of this thesis. What is then the role of PP-fibres? Only by answering this fundamental question can we hope to optimise fibre use and design in concrete to minimise the risk of fire spalling. Without such knowledge the application of PP-fibres to concrete can at best be a trial and error process. Schneider and Horvath (2003) summarise the various theories presently discussed in the literature as being based on an improvement of the permeability of the concrete due to:

- the formation of capillary pores when the fibres melt and burn,
- the development of diffusion open transition zones near the fibres,
- additional micro pores, which develop during the addition and mixing of fibres in the concrete mix, or
- additional micro cracks at the tip of the PP-fibres which develops during heating and melting.

Common to all these theories is that moisture transport is facilitated. One example, from article IV, of this modification of the moisture transport is shown in Figure 37 where the concrete samples with PP-fibres, E, F, I, J, M and N exhibit a clearly marked peak in the drying rate at a surface temperature of approximately 220°C. The comparable concretes without PP fibres, A and B have a lower and earlier peak. Concrete U is a reference concrete with w/c 0.62 compared with w/c 0.40 for the rest of the samples. Due to the heating conditions, with heating of 2°C/minute and the fact that the temperature is measured 2 mm from the surface so as not to disturb the weight measurement, the real surface temperature where the actual process of amplified drying is taking place is probably lower, i.e., approximately 200°C.

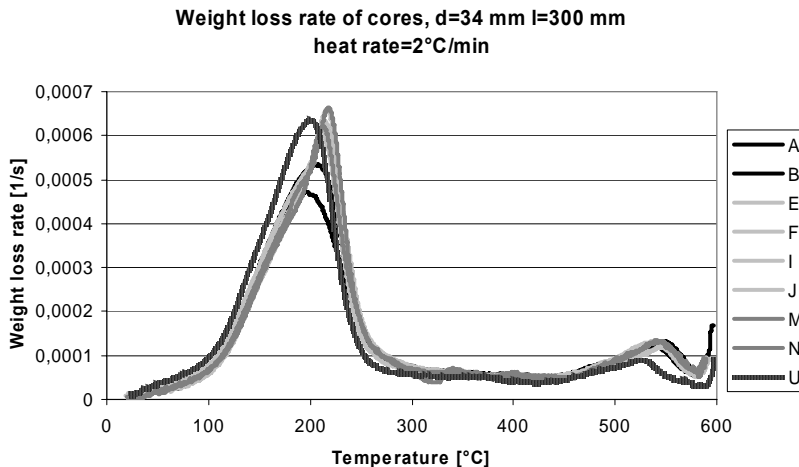

Figure 37 Drying rate of w/c=0.40 concretes with and without PP-fibres (see Article IV for more details). A and B are concrete without PP-fibres; E, F, I and J contain 18µm fibres; M and N contain 32 µm fibres; and U is a reference concrete with w/c=0.62. These curves correspond to the derivative of the curves shown in Figure 29.

The experiment was not conducted under flash-over fire conditions, where the heating rates are very much higher, but they indicates that PP-fibres modify moisture transport.

Similar results showing that PP-fibres modify the drying behaviour were presented by Kalifa et al. (2001) when testing concrete mixes and by Saravanta & Mikkola (1994) when testing mortar mixes.

If, in the following discussion, it is assumed that high moisture transport reduces spalling, the anti-spalling function of fibres in heated concrete may be due to one of the following three hypotheses:

- Hypothesis A. reduction of “breaking” pressures in the capillary pores
- Hypothesis B. modification of the mechanical properties, E-modulus, strength and fracture energy in the spalling zone
- Hypothesis C. local stress relaxation in the spalling zone due to drying creep.

These three different possible explanations (hypotheses) will be discussed in more detail below. Common for the three hypotheses is that a zone close to the surface, the so called “critical zone” as shown in Figure 38, will be affected by the presence or movement of moisture.

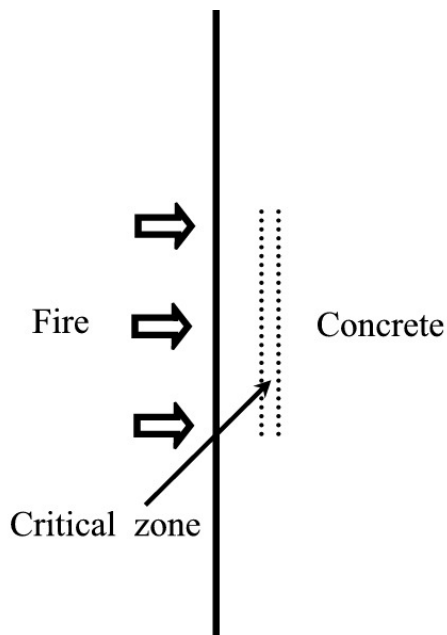

Figure 38 Zone affected by moisture presence or movement.

According to all three hypotheses, this zone will be where the spalling crack ultimately occurs which leads to the type of surface spalling, the results of which are shown in Figure 39.



Figure 39 Spalled material from the surfaces of three different concretes.

Let us now discuss these three hypotheses individually.

Hypothesis A: Pressure effect from moisture

As PP-fibres aid moisture transport the moisture pressure in heated concrete containing fibres is decreased.

The pressure effect from moisture, which was suggested early by Hasenjäger (1935), still seems to be the most common theory of the origin of spalling. As discussed in a chapter 2, the moisture clog phenomenon can increase the pore pressure and under certain circumstances liquid pressure initiated spalling, so called hydraulic spalling, might occur. During heating liquid moisture will expand and, at higher temperatures, evaporate. During evaporation at atmospheric pressure, i.e. at 100°C, the volumetric expansion from liquid to steam is approximately 1600 times. If there is insufficient space available to accommodate this expansion the pressure will rise.

In an experimental study by Kalifa et al. (2001) it was concluded that PP-fibres in concrete reduce the pore pressure by increasing the permeability of concrete at high temperatures. The specimens without the addition of PP-fibres reached 4 MPa which was higher than specimens with fibres. The heating scenario entailed the exposure of the specimen to a radiant heater with a temperature of 600°C which resulted in a heating less than the standard fire curve. None of the tested specimens spalled during the heat exposure.

In the experimental study described in Article II of this thesis, the measured pressure inside concrete that did not spall during heating was higher than the pressure in the concrete exhibiting spalling. The conclusion from that test series on self compacting concrete was that thermal stresses were the primary mechanism for spalling of the investigated self compacting concrete and that pore pressure was only secondary, Jansson (2006).

In a previous study Mindeguia et al. (2007) used the same test setup as Kalifa et al. (2001) to investigate the influence of the heating severity on pore pressure in concrete. The heating scenarios used entailed the exposure of the specimens to a heating panel at 600°C and 800°C as well as standard time temperature exposure, ISO 834. The specimen used for the heating panel tests were 30 × 30 × 12 cm and the ISO 834 specimens 70 × 60 × 15 cm. The maximum measured pressure in a concrete with w/c= 0.54 was 1.5 MPa during exposure to a heating panel at 600°C and approximately 0.2 MPa during exposure

to a heating panel at 800°C. No spalling occurred during these heating panel tests. When the same concrete was tested with ISO 834 exposure it spalled and the maximum pressure was only approximately 0.2 MPa. A similar behaviour was recorded in a concrete with $w/c = 0.38$. Conclusions from the tests were that the origin of spalling was not the pore pressure. Slow heating led to high pore pressure and no spalling, while fast heating led to low pore pressure and spalling. These findings are in line with the experimental results concerning residual permeability shown in Article IV where it was shown that rapid heating led to an increase in surface cracking.

The above discussion illustrates that although PP-fibres reduce the pore pressure, the pore pressure alone is not the mechanism for spalling. One should note that this discussion is only valid for one-sided fire exposure of concrete samples. When concrete is exposed from two or more sides the role of pore pressure may be much more important, see for example Figure 3 in Chapter 2.1.

Hypothesis B: Effect of moisture on mechanical properties

The presence of moisture influences the mechanical properties. PP-fibres facilitate moisture transport, peaking around 200°C, i.e., the evacuation of moisture at high temperatures from the critical zone shown in Figure 38 might be faster if the concrete contains PP- fibres. Important then is to consider whether the presence of trapped moisture during heating is unfavourable from a mechanical viewpoint.

At room temperature, Pihlajavaara (1974) showed that the presence of moisture reduces the flexural strength of cement mortar, Figure 40. The tests were performed on specimens in moisture equilibrium with their surroundings.

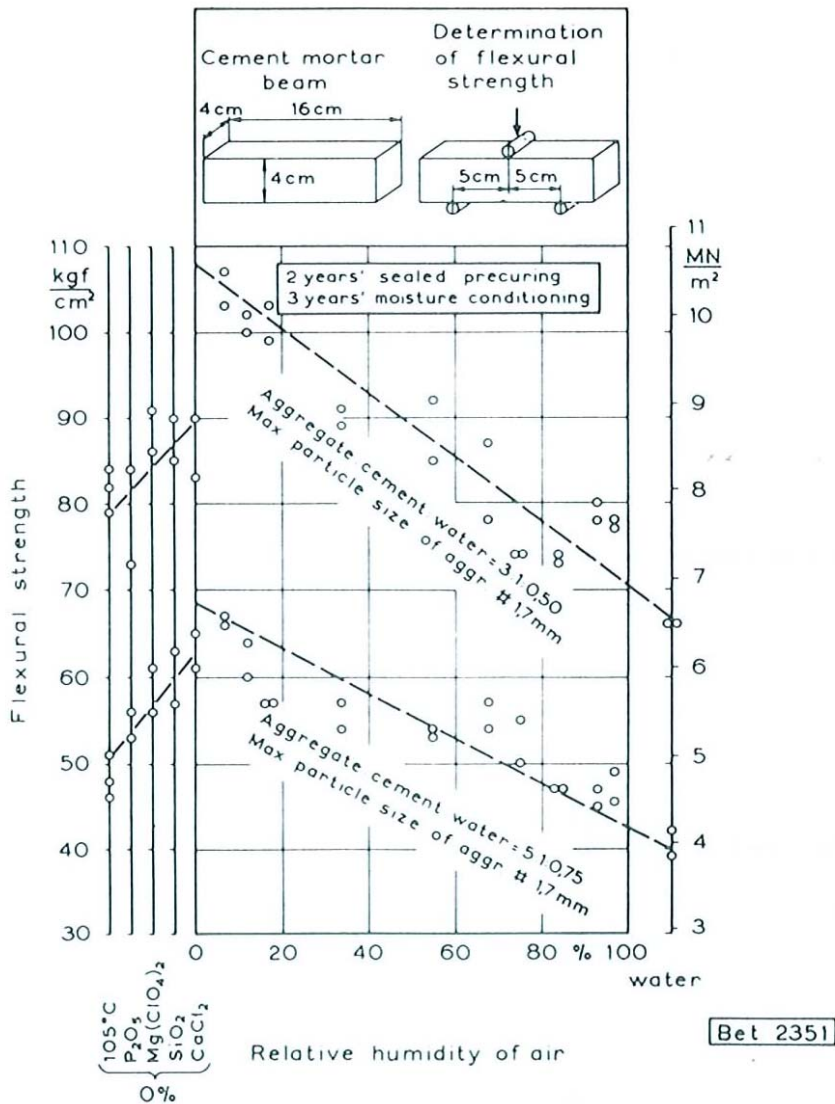

Figure 40 The effect of relative humidity on the flexural strength, reproduced from Pihlajavaara (1974).

The mechanical properties cannot be determined locally in a rapidly heated specimen, containing trapped moisture. However, an indication of the effect of trapped moisture during heating can be seen from experiments conducted on specimens heated and tested under sealed conditions.

A literature review conducted by Lankard et al. (1971) shows that the compressive strength of concrete heated under sealed conditions exhibits a dramatic decrease, see Figure 41. The same conclusion was drawn by Schneider & Horvat (2003) when reviewing results from Berto & Polivka (1972). These results show a 30 % reduction of the compressive strength when testing a sealed specimen compared to an unsealed specimen at 150°C.

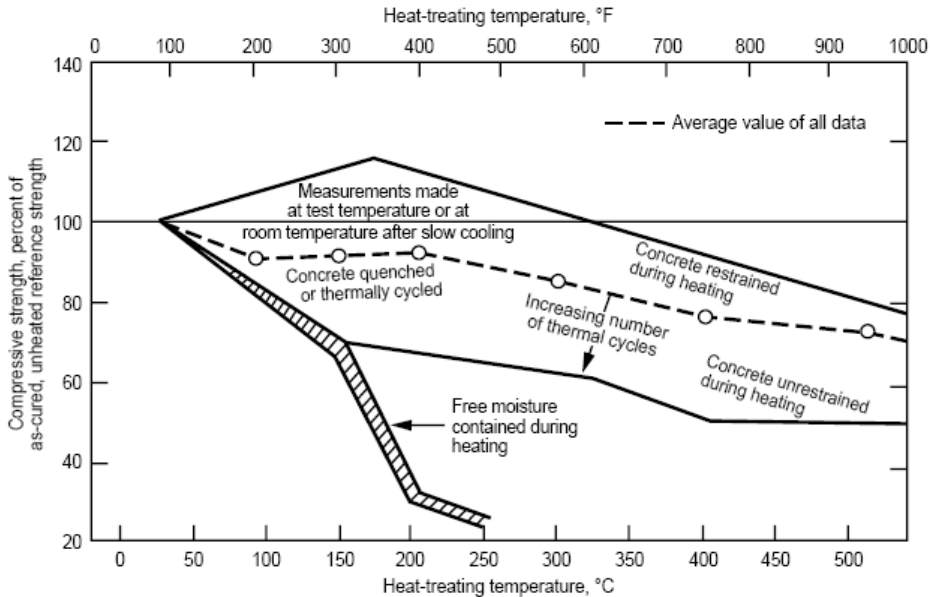

Figure 41 Compressive strength of concrete heated under different conditions, reproduced from Lankard et al. (1971)

At room temperature, the Young's modulus is much higher when more moisture is present, Betonghandbok Material (1982). This is explained by the fact that pore water is almost incompressible and, if it is not easily moved by the pressure, the Young's modulus will increase. It is highly plausible that a situation will arise when the moisture transport from the gel pores to the capillary pores and further transport away from the high pressure zone will be restricted during heating and the critical zone shown in Figure 38 will become stiff.

According to Zhang et al. (2002), the loss of moisture from concrete due to heating always leads to a decrease in brittleness. This conclusion was based on the heating and drying of notched beams in a test program including heating to different temperatures for a variety of heating times.

A stiff cement matrix zone around an expanding aggregate can be the reason for the development of a crack parallel to the fire exposed surface. When PP-fibres are present the moisture kept at a high temperature in the critical zone will be reduced, leading to less stiffness and less cracking. This plausible effect has not been experimentally verified.

Very few experiments to measure the E-modulus during sealed conditions can be found in the literature and the conclusions are not consistent. Schneider & Horvat (2003) conclude based on six test series, four performed under sealed conditions and two unsealed, that sealing of the specimens did not have a significant effect on the E-modulus for limestone concretes. In tests performed by Lankard et al. (1971) on gravel concrete, however, the effect of sealed conditions was dramatic. When the temperature was 100°C the E-modulus was reduced by 50 %.

Hypothesis C: Drying creep effect

As shown previously, PP-fibres facilitate moisture transport peaking at around 200°C. Thus the evacuation of moisture at high temperatures from the critical zone shown in Figure 38 will be faster if the concrete contains PP- fibres. Hypothesis B dealt with the effect of the presence of moisture on mechanical properties. In this discussion, the effect of moisture transport from the critical region will be discussed.

During first time heating of a loaded specimen the strain components can be described as in **Fel! Hittar inte referenskölla.** The total strain is divided into the components: thermal expansion, transient strain, creep strain, and elastic strain. In an analogy to this description, the transient strain will, in a given situation of restrained thermal expansion during heating, relax the stresses originated from thermal expansion. This is very important in the behaviour of heated concrete.

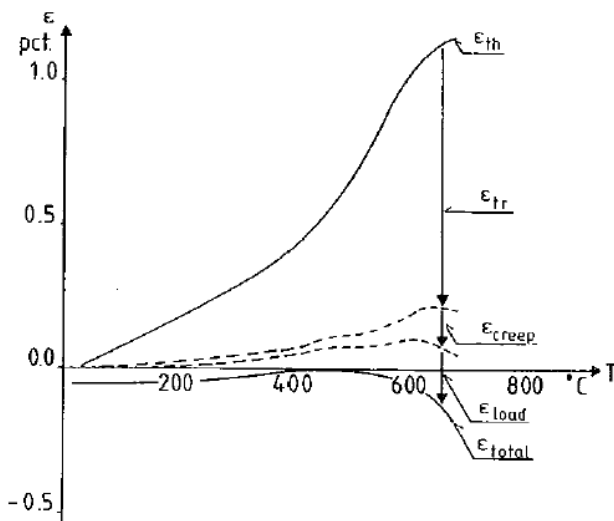

Figure 42 Strain components during first time heating and constant load. Total strain (ϵ_{total}) seen as a sum of the thermal expansion (ϵ_{th}), transient strain (ϵ_{tr}), creep strain (ϵ_{creep}) and elastic strain (ϵ_{load}) (reproduced from Anderberg & Thelandersson (1976)).

The nature of the transient strain in a heated unsealed specimen is, according to Khoury et al. (2002), a mixture of “transitional thermal creep” (TTC) and drying creep, i.e., in **Fel! Hittar inte referenskölla.**, $\epsilon_{tr} = TTC + \text{drying creep}$. The TTC component was first found by Hansen & Eriksson (1966) when they tested loaded and unloaded cement paste and mortar specimens submerged in water and heated to 100 °C. These experiments illustrated that a specimen first loaded and then heated exhibited greater deformation than a specimen first heated and then loaded. The fact that the tests were performed under water lead to the conclusion that transitional thermal creep is a different phenomenon to drying creep.

How much of the transient strain originates from TTC relative to drying creep during a test such as that shown in **Fel! Hittar inte referenskölla.**, has never been determined. According to Bazant & Kaplan (1996) the drying creep (also called “the Pickett effect”) is totally dominant. The drying creep component was also highlighted by Thelandersson

(1982) as a highly important phenomenon during heating. In a recent experimental study, Petkovski & Crouch (2008) concluded, from tests on concrete under partly sealed conditions, that the Load Induced Thermal Strain (LITS) in concrete is reduced if the moisture movement is restricted, i.e., if drying creep is minimised, thereby confirming the importance of drying creep in transient strain. LITS is the difference between heating without load relative to heating under load, minus the initial elastic strain.

The strain plateau shown in the “free thermal strain” experiments, presented in Article IV, might be an indication of an accelerated drying creep phenomena. A free thermal strain experiment during heating does not really represent free expansion. Stresses from thermal expansion are found in the cross-section of a heated specimen with a thermal gradient; compressive stresses near the surface and tensile stresses further from the surface of the specimen, Bazant et al. (1996). These stresses arise due to the fact that the inner colder regions in the core will expand slightly less during the heat exposure and to a certain degree restrain the outer hotter region. When the outer region approaches approximately 200°C, the drying creep phenomenon promoted by PP- fibres appears to relax some of the compressive stresses, which are mainly from expansion of the aggregate. Bazant et al. (1996) proposed a hypothesis that the creep viscosity (creep) is a function of the micro diffusion flux of water between the gel pores and the capillary pores. According to this theory the mechanism promoting creep is the flow out of or in to the gel pores and this flow is dependent on temperature and relative humidity. Any drainage of the capillary pores promoted by the presence of PP- fibres will probably create a flow from the gel pores to the capillary pores, thereby promoting creep. This effect of PP- fibres on the “free” thermal expansion must be investigated further.

Drying of concrete during heating leads to drying creep which relaxes stresses in the material. Thus, in a material with low permeability the drying is restricted and higher stresses will occur. When PP-fibres are present, an extra “relaxation” peak in the material around 200°C, will be present, which indicates that the PP-fibres may facilitate drying creep.

In summary, the effect of PP- fibres might be a mixture of the three hypotheses presented above. In the case that all three are valid their relative significance will be different for different concrete compositions and moisture contents, but during the experiments performed in this experimental study, the pressure effect in the capillaries from moisture is believed to be of only secondary importance. All three hypotheses require further study in order to be confirmed or refuted. Indeed, their relative importance in different types of concrete (as discussed above) cannot be determined before their very basis in fact has been established.

6 Conclusions

The objective of the work presented in this thesis has been to investigate some properties of concrete and their relationship to fire spalling. In particular, the thermal properties and the role of moisture in the fire spalling process have been focused on.

It is clear that the heat exposure is in some way involved in the spalling processes, therefore the thermal properties are important. The thermal properties, i.e., thermal conductivity, thermal diffusivity and the volumetric specific heat, at high temperatures were investigated using the TPS method. A temperature calculation based on the measured values for a specific concrete was compared to the temperature measurements conducted during a large scale test on a concrete slab of the same concrete. The results from the calculations corresponded well to the temperatures measured during the test.

Another important issue that is often addressed in the literature as important to the mechanism of fire spalling of concrete is the pressure in the capillary system. In certain circumstances this might be the case, as for an example when the heat exposure is from more the one side, but based on measurements of pressure performed in this project it is concluded that during one-sided fire exposure, the spalling initiator was not the pressure in the investigated concrete.

A theory concerning the role of moisture in fire spalling based on experiments performed on concrete with and without PP- fibres, was presented. It was shown in small and large scale fire experiments that PP- fibres reduced spalling. A plausible explanation of the spalling retarding mechanism of PP- fibres is that the addition of fibres promotes moisture transport at temperatures around 200°C. This peak in moisture transport was shown in drying experiments and the effect on thermal expansion was clearly seen as a plateau in the free thermal expansion curve. Based on these observations and references in the literature a theory based on two phenomena for the function of PP- fibres in high temperature concrete, was presented. A possible third phenomena, the pressure in the capillary system, was concluded to be only secondary in the investigated concretes, see above).

First, the presence of PP- fibres leads to a lower degree of saturation of the material. It was found in the literature that the compressive strength is reduced if moisture is kept inside and from a parallel to room temperature behaviour it is plausible that the Young's modulus rises relative to saturation. This is not yet confirmed in high temperature experiments. The second phenomenon in the theory is that the moisture transport amplified by PP- fibres leads to a relaxation of thermal stresses by drying creep.

7 Future research

The work presented in this thesis was originally intended to have a focus on theoretical modelling of fire spalling in concrete. As stated in the introduction it rapidly became clear that a significant amount of experimental data is needed before realistic models can be developed to the point where it is meaningful to conduct extensive modelling with any degree of accuracy. This thesis presents some important experimental results and test methods to improve our understanding of fire spalling and will provide the basis for model development in the future. Further experimental data is however needed concerning, e.g., creep, fracture mechanics, chemical processes in concrete and moisture transport in general.

Further, the phenomenon of fire spalling and the spalling reducing effect of PP- fibres are not yet understood in detail. As the role of moisture in fire spalling is often highlighted in this thesis and in the research community, the next step in this research area should be to investigate the three hypothesises presented experimentally. Both the local moisture transport close to the surface and the effect of trapped moisture at high temperature. The test methods developed in this work could be further improved by comparison to alternative methods including the use of fiber optic sensors for pressure measurement. Such sensors have been applied in a limited number of applications but initial results are highly promising. Presently many pressure measurements from different sources in the literature are still contradictory. Optical fibers may represent our first real opportunity to resolve such contradictions and ultimately understand the relationship between moisture transport, pressure and spalling.

Another method which has recently received some attention is the use of NMR (Nuclear Magnetic Resonance spectroscopy) at high temperatures to register the transport of moisture during a heating cycle. This method is in its infancy but could be used to confirm or refute one of the oldest and most well-established theories to explain fire spalling, i.e. the moisture clog theory. As presented in this thesis, some aspects of this theory is questionable and experimental resolution of its validity would provide a benchmark for further research.

As our understanding of fire spalling improves yet further models should be developed and validation of these models against relevant experimental data performed. Well defined models of fire spalling in concrete would facilitate the development of new, designer, formulations for specific future applications.

8 References

Abrams M. S. (1968) “*Compressive strength of concrete at temperatures to 1600 F*”, Temperature and Concrete, ACI Publication SP 25, 1968

ACI: Guide on Determining of Fire Endurance of Concrete Elements (1981), REPORT NO ACI 216R.81 Concrete International February, 1981

Ali. F. A., Connolly R., Sullivan P. J. E., (1996) “*Spalling of High Strength Concrete at Elevated Temperatures*” J. Applied Fire Science, Vol 6(1) pp. 3-14, 1996-97

Anderberg Y. & Pettersson O. (1991) ” Fire Safety Engineering of concrete structures” (in Swedish) Byggeforskningsrådet, November, 1991

Anderberg Y. & Thelandersson S. (1976) “*Stress and deformation characteristics of concrete at high temperatures*”, Lund Institute of Technology, Bulletin 54, Sweden, 1976

Arita, Harada, Miyamoto (2002) “*Thermal spalling of high-performance concrete during fire*” Second International Workshop Structures in Fire – Christchurch – March 2002

Barret (1854) “*On the French and other methods of constructing iron floors*”, Civil Engineering and Architect’s Journal, Vol XVII, 1854, pp 94

Bazant Z. P. (1970) “*Delayed thermal dilation of cement past and concrete due to mass transport*” Nuclear Engineering and Design 14 (1970) 308-318

Bazant Z. P. & Thonguthai W. (1979) “*Pore Pressure in Heated Concrete Walls: Theoretical Prediction*” Mag. Of Conc. Research, June 1979

Bazant Z. P., Kaplan M. F. (1996) “*Concrete at High Temperatures- Material properties and mathematical models*” Book published by Longman Group Limited 1996

Bazant, Z. P.(2005) “*Concrete Creep at High Temperature and its Interaction with Fracture: Recent Progress*”, Concreep-7 Conference: Creep, Shrinkage and Durability of Concrete and Concrete Structures, pp 449–460, 2005

Bengtsson O. (1997) “*Fire exposed concrete beams with slender cross-section*” (in Swedish), Brandforsk Projekt 273-941, SP Report 1997:35, 1997

Bennet J, Claesson J., Thelandersson S (1976) ”*Calculations of Temperature, moisture and Pressure Distributions in Concrete Exposed to Fire*” Report from Department of Mathematical Physics and Division of Structural Mechanics, Lund, November 1976

Bertero V. V., Polvka M. (1972), “*Influence of thermal exposure on mechanical characteristic of concrete*” ACI Int. Sem. On Concrete for Nuclear Reactors, Berlin, ACI Publication SP-34, 1972 cited in Schneider U. & Horvat J.(2003) “*Behaviour of ordinary concrete at high temperature*”, Technische Universität Wien, Heft 9, 2003

Betonghandbok Material (1982) *Concrete Handbook. Materials* (in Swedish), Svensk Byggtjänst, second edition, 1982

Boström L. (2006) “*Investigation of damage to a bridge caused by a road tanker fire*” Brandposten No.34 2006: 28-29

Boström L. & Jansson R.(2007)“*Fire spalling of self-compacting concrete*” 5th International RILEM Symposium on Self-Compacting Concrete, 3-5 September 2007, Ghent, Belgium

Bottke (1931) “*Verhalten von Eisenbetonbauten im Feuer“ Beton und Eisen“* 30, 1931 , cited in Meyer-Ottens C. (1972) “*Zur Frage der Abplatzungen an Betonbauteilen aus Normalbeton bei Brandbeanspruchung*”, PhD-thesis, Braunschweig, Germany, 1972.

Breunese A.J., Fellingner J. H. H. (2004) “*Spalling of Concrete - An Overview of Ongoing Research in the Netherlands*”, Workshop - Structures in Fire, Ottawa, May, 2004

Bushev V. P., Pchelintsev V. A., Fedorenko V. S., and Yakovlev A. I. (1970) “*Fire Resistance of Buildings*”. Book translated from Russian 1978, Amerind Publishing

Connolly R. J. (1995) “*The Spalling of Concrete in Fire*” PhD thesis, Ashton University, 1995

Consolazio, G. R.; McVay, M. C.; Rish, J. W. (1997) “*Measurement and Prediction of Pore Pressure in Cement Mortar Subjected to Elevated Temperature*” NIST SP 919; September 1997.International Workshop on Fire Performance of High-Strength Concrete. Proceedings, pp.125-148, 1997

Copier, W.J. (1979) “*Spalling of normalweight and lightweight concrete on exposure to fire*” Report 24(2), Heron, Holland, 1979.

Dal Pont S. & Ehrlicher A. (2004) “*Numerical and experimental analysis of chemical dehydration, heat and mass transfers in a concrete hollow cylinder submitted to high temperatures*” International Journal of Heat and Mass Transfer 47 (2004) pp. 135–147

Dougill J. W. (1965)“*Some effects on the thermal volume changes on the properties and behaviour of concrete*” Proceedings of the conference “The structure of concrete – and its behaviour under load” Cement and Concrete Association, London, September 1965

Dougill J. W. (1971) “*The effect of high temperature on strength of concrete with reference to thermal spalling*” PhD Thesis, London University, 1971

Dougill J. W. (1972) “*Modes of failure of concrete panels exposed to high temperature*” *Magazine of Concret Research*, Vol 24, No 79, June 1972

EN 1363-1 (1999) *Fire Resistance tests- Part 1: General requirements*, European Standard, August, 1999

Endell R. (1929) “*Versuche über Langen- und Gefügeänderung von Betonzuschlagstoffe und Zementmörteln unter Einwirkung von Temperaturen bis 1200 °C*” Detcher Ausschluss für Eisenbeton, Heft 60, Berlin, 1929, cited in Meyer-Ottens C. (1972) “*Zur Frage der Abplatzungen an Betonbauteilen aus Normalbeton bei Brandbeanspruchung*”, PhD-thesis, Braunschweig, Germany, 1972.

Eurocode 2 (1995) ENV 1992-1-2: *Design of Concrete Structures – Part 1-2: General Rules- Structural fire design*, November, 1995

Eurocode 2 (2004) EN 1992-1-2: *Design of Concrete Structures – Part 1-2: General Rules- Structural fire design*, December, 2004

Fib: Fire Design of Concrete Structures – Materials, structures and modelling (2007), State-of-the-art Report, fib Working Party 4.3-1, Bulletin 38

Gary, M.(1917), “*Fire tests on reinforced concrete buildings*”, Germany, 1917, cited in Meyer-Ottens C. (1972) “*Zur Frage der Abplatzungen an Betonbauteilen aus Normalbeton bei Brandbeanspruchung*”, PhD-thesis, Braunschweig, Germany, 1972.

Hager I. (2004) – “*Propriétés Mécaniques des Bétons à Haute Performance à Haute Température – Évolution des Principales Propriétés Mécaniques*”, Thèse de Doctorat, Ecole Nationale des Ponts et Chaussées, Paris, 2004, 172 pp.

Hansen, T. C. & Eriksson, L (1966) “*Temperature change effect on behaviour of cement paste, mortar and concrete under load*”, *ACI Journal* 63 (4) (1966) cited in Petovski M., Crouch R. S. (2008) “*Strains under transient hygro-thermal states in concrete loaded in multiaxial compression and heated to 250 °C*” *Cement and Concrete Research* 38, 2008

Gustafsson A. H. & Martin L. D. (1977) “*PCI: Design for Fire Resistance of Precast Prestressed Concrete*” *Prestress Concrete Institute*, USA, 1977

Gustafsson, S.E. (1991), “*Transient Plane Source (TPS) Technique for Thermal Conductivity and Thermal Diffusivity Measurements of Solid Materials*,” *Rev. Sci. Instrum.* 62(3), 1991, pp 797-804

Gustafsson, S.E. & Long, T. (1995), “*Transient Plane Source (TPS) Technique for Measuring Thermal Properties of Building Materials*,” Fire and Material, Vol. 19, 1995, pp. 43-49

Harada, K.; Terai, T. (1997) “*Heat and Mass Transfer in the Walls Subjected to Fire*”, U.S./Japan Government Cooperative Program on Natural Resources (UJNR). Fire Research and Safety. 13th Joint Panel Meeting. Volume 1. March 13-20, 1996, Gaithersburg, MD, Beall, K. A., Editor(s), pp 423-435, 1997.

Harmathy, T. Z.(1965), “*Effect of moisture on the fire endurance of building materials*”, Moisture in Materials in Relation to Fire Tests, ASTM Special Technical Publication No. 385, pp 74-95, 1965

Harmathy, T. Z.(1970), “*Thermal Properties of Concrete at Elevated Temperatures*”, Journal of Materials, Vol 5, No 1, March 1970

Harmathy T. Z. (1993) “*Fire Safety Design & Concrete*” Book published by Longman Group UK Limited 1993

Hasenjäger (1935) “*Über das Verhalten des Betons und Eisenbetons im Feuer und die Ausbildung von Dehnungsfugen im Eisenbetonbau*” Dissertation, Technische Hochschule Braunschweig 1935, , cited in Meyer-Ottens C. (1972) “*Zur Frage der Abplatzungen an Betonbauteilen aus Normalbeton bei Brandbeanspruchung*”, PhD-thesis, Braunschweig, Germany, 1972.

Hedenblad G. & Nilsson L. -O. (1985) “*Degree of Capillary Saturation –A tool for accurate determination of the moisture content in concrete*” Report TVBM-3022 (in Swedish), Lund, 1985, 69 pp.

Hertz K. (1984) “Explosion of Silica-fume Concrete” Fire Safety Journal, no 8,1984/85

Hertz K. (2003) “*Limits of Spalling of Fire-Exposed Concrete*” Fire Safety Journal 38, 2003

Hyatt T. (1878) , “*Portland-cement-concrete combined with iron, as a building material, with reference to economy of metal in construction, and for security against fire in the making of roofs, floors, and walking surfaces*” ,Printed for private circulation, Chiswick Press, 1877

Incropera F. S. & D. P. DeWitt (1996) “*Fundamentals of Heat and Mass Transfer*”. John Wiley & Sons 1996

Jansson R. (2006) “*Thermal stresses cause spalling*” Brandposten 33, 2006

Kalifa P.,Che’ne’ G. & Galle’ C. (2001)“*High-temperature behaviour of HPC with polypropylene fibres From spalling to microstructure*” Cement and Concrete Research 31 ,2001, pp. 1487–1499

- Kalifa P., Menneteau F.D., Quenard D. (2000)** “*Spalling and pore pressure in HPC at high temperatures*” *Cement and Concrete Research* 30 (2000) pp.1915-1927
- Khoylou N. (1997)** “*Modelling of moisture migration and spalling behaviour in non-uniformly heated concrete*”, PhD thesis, University of London, March, 1997
- Khoury G. (2000)** “*Effect of fire on concrete and concrete structures*”, *Prog. Struct. Engng Mater.* 2000; 2
- Khoury G. A., Majorana C. E., Pesavento F., Schrefler B. A. (2002)**, “*Modelling of Heated Concrete*” *Mag. of Conc. Research* No 2 2002
- Kordina K. & Meyer-Ottens C. (1981)** “*Beton Brandschutz Handbuch*“. Beton-Velag GmbH, Germany, 1981
- Kusterle W. et al. (2004)** “*Brandbeständigkeit von Faser-, Stahl- und Spannbeton*” Heft 544, Bundesministerium für Verkehr, Innovation und Technologie, Wien, pp.1-221, 2004
- Lankard D. R., Birkimer D. L., Fondriest F. F. & Snyter M. J. (1971)** “*Effects of moisture content on the structural properties of portland cement concrete exposed to 500 F*”. ACI Special Publication SP 25, Detroit 1971
- Lea F. C. (1920)** “*The effect of temperature on some of the properties of materials*”. *Engineering*, August 1920, pp. 293-298
- Lindblad Å., Pettersson O., Schmidt B. and Ödeen K. (1966)** “*Fire in storehouse 6 in the free port of Stockholm*” (in Swedish), Väg- och vattenbyggnadsverket nr 12, 1966
- Malhotra H. L. (1984)**, ‘*Spalling of Concrete in Fires*’, Construction Industry Research and Information Association, Technical Report No. 118, London 1984
- Meyer-Ottens C. (1972)**, *Zur Frage der Abplatzungen an Betonbauteilen aus Normalbeton bei Brandbeanspruchung*, PhD-thesis, Braunschweig, 1972
- Mindeguia J-C., Pimienta P., La Borderie C., Carre H. (2007)**, “*Experimental study of fire behaviour of different concretes – thermo – hydral and spalling analysis*” *fib Task Group 4.3 workshop “Fire Design of Concrete Structures – From Materials Modelling to Structural Performance”* Coimbra, Portugal, November 8-9, 2007
- Nekrasov K. D., Zhukov V.V. & Shevchenko V.I. (1967)** “*Investigation of heating large blocks of refractory concrete from one side*” *Refractories and Industrial Ceramics* Volume 8, Numbers 5-6 / May, 1967
- Neville A. M. (1977)** “*Properties of concrete*”. Pitman Publishing Limited, 1977

Neville A. M. (1996) *Properties of Concrete*. Fourth and final Edition, John Wiley & Sons, Inc, 1996

Odelson J. B., Kerr E. A., Vichit-Vadakan W. (2007) "Young's modulus of cement paste at elevated temperatures". *Cement and Concrete Research* 37 (2007) 258–263

Pettersson O. Ödeen K. (1978) "Fire Safety Engineering" (in Swedish), Lieber Förlag, 1978

Petkovski M., Crouch R. S. (2008) "Strains under transient hygro-thermal states in concrete loaded in multiaxial compression and heated to 250°C". *Cement and Concrete Research* 38, 2008

Phan T. L. (2002) "*High-Strength Concrete at High Temperature – An Overview*" Utilization of High Strength/High Performance Concrete, 6th International Symposium. Proceedings. Volume 1. June 2002, Leipzig, Germany, König, G.; Dehn, F.; Faust, T., Editor(s), 501-518 pp, 2002.

Powers T. C. & Brownyard T. L. (1948) "*Studies of the physical properties of hardened Portland cement paste*" Bulletin 22, Portland Cement Association, Chicago, March 1948

Preston F. W., White H. E. (1934) "*Observations on spalling*" *Journal of the American Ceramic Society*, Volume 17, Issue 1-12, Page 137-144, Dec 1934

Sanjayan G & Stocks L. J. (1993) "*Spalling of High-Strength Silica Fume Concrete in Fire*" *ACI Materials Journal*, Vol 90, Issue 2, 1993

Saravanta L. & Mikkola E., (1994) "*Fibre mortar composites under fire conditions: effects of ageing and moisture content of specimens*" *Materials and Structures*, 1994, 27, 532-538

Sato (1965) "*Explosive spalling of prestressed concrete in fire*". Fire resistance of prestressed concrete; proceedings of a symposium on the fire resistance of prestressed concrete, held under the auspices of the F.I.P. Commission on Fire resistance of prestressed concrete at Braunschweig, Germany June 1965,

Shekarchi M., Debicki G., Billard Y. & Coudert L. (2003) "*Heat and Mass Transfer of High Performance Concrete for Reactor Containment Under Severe Accident Conditions*" *Fire Technology*, 39, 63–71, 2003

Schneider U. (1976) "*Behaviour of concrete under thermal steady state and non-steady state conditions*" *Fire and Materials*, 1 (3), 1976

Schneider U. (1985) "*Properties at high temperatures: Concrete*" Editor: U. Schneider, Rilem committee 44-PHT, June 1985

Schneider U. (2007) Personal communication

Schneider U., Diederichs U. (1981) “*Physical Properties of Concrete from 20 C to melting*” Betongwerk + Fertigteile – Technik, Heft 3, 1981

Schneider U. & Horvat J.(2003) “*Behaviour of ordinary concrete at high temperature*”, Technische Universität Wien, Heft 9, 2003

Schneider U. & Schwesinger P., (1990) “*Mechanical Testing of Concrete at High Temperatures*” Editors: U. Schneider & P. Schwesinger , Rilem committee 74-THT, February 1990

Sellevoid E. J. & Bjøntegard Ø. (2006) ”*Coefficient of thermal expansion of cement paste and concrete: Mechanisms of moisture interaction*” Material and Structures (2006) 39:809-815

Shirayama K. (1976), “*Experimental study on explosive spalling of lightweight aggregate concrete in fire*”, Proceedings 10th Congress of International Association for Bridge and Structural Engineering, Tokyo, 1976

Shorter G. W. & Harmathy T. Z. (1961) “Proceedings, Institute of Civil Engineers, Vol. 20, 1961, p. 313 as cited to by **Harmathy, T. Z.(1965)**, “*Effect of moisture on the fire endurance of building materials*”, Moisture in Materials in Relation to Fire Tests, ASTM Special Technical Publication No. 385, pp 74-95, 1965.

Sundius N. (1931) “*Investigation of fire exposed concrete by microscopy*” in Swedish) Betong Häfte 2, 1931

Swedish Concrete Association (2004) “*Preliminary guidelines for avoiding fire spalling in fire exposed concrete structures*” (in Swedish) BETONG, May, 2004

Swedish Tariff Association (1959) “*Concrete and Fire*” (in Swedish), A book published by the Swedish Tariff Association, 1959

Sönnerberg S (1952) “*The fight against fire*” (in Swedish), A book published by Berneces Förlag AB, Malmö, Sweden, 1952

Thelandersson S. (1972) “*Effect of high temperatures on tensile strength of concrete*” Lund Institute of Technology, Bulletin 26, Sweden, 1972

Thelandersson S. (1974 a) “*Mechanical behaviour of concrete under torsional loading at transient, high temperature conditions*” Lund Institute of Technology, Bulletin 46, Sweden, 1974

Thelandersson S. (1974 b) ”*Betongkonstruktioner vid höga temperaturer -en översikt*” (in Swedish), VAST, September 1974

Thelandersson S. (1982)”*On the multi-axial behaviour of concrete exposed to high temperature*” Nuclear Engineering and Design 75, 1982, pp. 271-282

Waubke N. V. (1966) “*Transportphänomene in Betonporen*“, Dissertation, Technische Universität Braunschweig, 1966

Waubke N. V. (1973) “*Über eine physikalischen Gesetzmäßigkeit der Festigkeitsverluste von Portlandzementbetonen bei Temperaturen bis 100 °C*“ Sonderforschungsbereichs 148, Heft 2.. TU. Braunschweig, 1973, as cited by Thelandersson S. (1974 b)

Waubke N. V. & Schneider U. (1973) “*Tensile stress in concrete due to fast vapour flow*“, Proceedings of the international RILEM symposium “Pore Structure and Properties of Materials”, Prague, September, 1973

Yanko W. A. (2004) “*Experimental and numerical evaluation of concrete spalling during extreme thermal loading*” PhD thesis University of Florida 2004

Zhang B., Bicanic N., Pearce C., Phillips D. (2002) “*Relationship between brittleness and moisture loss of concrete exposed to high temperatures*” Cement and Concrete Research 32 (2002) 363–371

Zhukov V. V. (1976) “*Reasons of Explosive Spalling of Concrete by Fire*”, Beton i zhelezobeton (Concrete and Reinforcement Concrete), No. 3, 1976

Zoldners N. G. (1968) “*Thermal properties of concrete under sustained elevated temperatures*” Temperature and Concrete, ACI Publication SP 25, 1968

Ödeen, K. & Nordström, Å.(1972), “*Thermal properties for concrete at high temperatures*”, Statens Provningsanstalt, Brandtekniska Laboratoriet 1972:1, Stockholm

Publication I. Jansson R. "Measurement of Concrete Thermal Properties at High Temperature" Proceedings from the fib Task Group 4.3 workshop "Fire Design of Concrete Structures: What now? What next?", Milan, Italy, December 2-3, 2004

Measurement of Concrete Thermal Properties at High Temperature

Robert Jansson

M.Sc. Project Manager,
Fire Resistance
SP, Swedish National
Testing and Research
Institute, Fire Technology
Sweden

Summary

A method for the determination of concrete thermal properties at high temperature is examined in this paper. The so-called TPS Method (Transient Plane Source) makes it possible to simultaneously evaluate the thermal conductivity, thermal diffusivity and specific heat in the temperature range 30 – 1000 K.

The standard technique is briefly described, and some measurement carried out on self compacting concrete reinforced with polypropylene fibres are presented. The theoretical results based on the values of the thermal properties measured in the test turns out to be in satisfactory agreement with the measurements concerning a full-scale fire test. Finally, a comparison is made between the results obtained with TPS and those obtained with MDSC (Modulated Differential Scanning Calorimeter).

Keywords: self-compacting concrete; thermal properties.

1. Background

1.1 Introduction

The heat propagation in a material governs the chemical and structural degradation processes in a fire situation. Therefore the thermal properties of concrete are of fundamental interest when theoretical predictions of the behaviour in fire are done. In this short paper the use of a transient method for simultaneously determination of the thermal conductivity, thermal diffusivity and specific heat in self-compacting concrete is investigated. When using the Transient Plane Source (TPS) method a specimen in thermal equilibrium is exposed to a heat pulse and by using the recorded transient thermal response of the material and the geometrical data for the sensor a calculation of the thermal properties can be done.

1.2 Previous studies

Determination of the thermal properties of concrete at high temperature is not a new issue. As an example Ödeen and Nordström [1] performed measurements on

concrete at temperatures from room temperature up to 1000 °C. The measurements at high temperature were performed with the Stålhane-Pyk method (thermal conductivity) and a Dynatech calorimeter (specific heat). The thermal conductivity measurements show the typical decay at high temperatures. When the material is cooling after an exposure at high temperature the thermal conductivity is approximately constant, see Fig. 1.

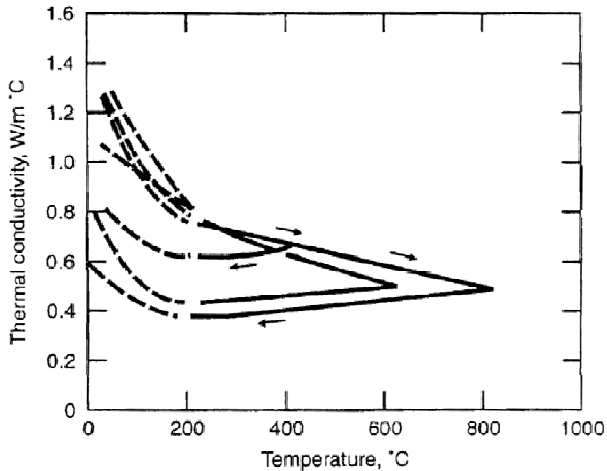

Fig. 1 - The temperature dependent thermal conductivity for concrete with w/c = 0.7 (Ödeen and Nordström 1972). The cooling phase is included in the diagram.

In the literature there exist several good compilations of data of the thermal properties for different qualities of concrete at high temperature [2,3,4]. One example, which shows the specific heat, is shown in Fig. 2.

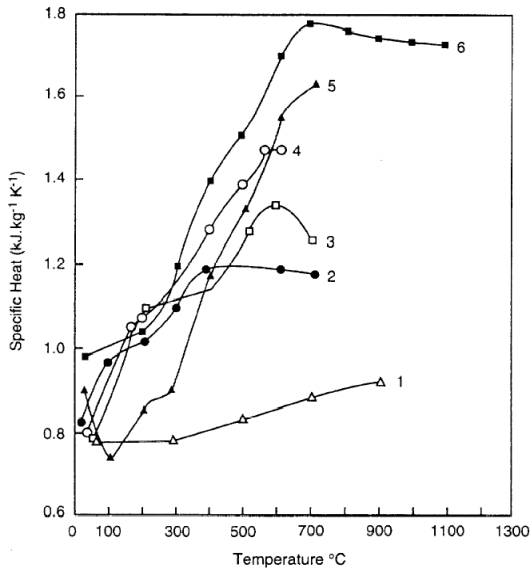

Fig. 2 - Effect of temperature on measured specific heat of various concretes. Compilation made by Bažant and Kaplan [4]. (1) granite aggregate concrete (Ödeen [5]); (2) limestone aggregate concrete (Collet and Tavernier [6]); (3) lime stone aggregate concrete (Harmathy and Allen [7]); (4) siliceous aggregate concrete (Harmathy and Allen [7]); (5) limestone aggregate concrete (Hildebrand, et al. [8]); (6) siliceous aggregate concrete (Hildebrand, et al. [8])

The prescribed values in the Eurocode 2 part 1-2 [9] are shown in Fig. 3. The thermal conductivity is described by an upper and lower limit.

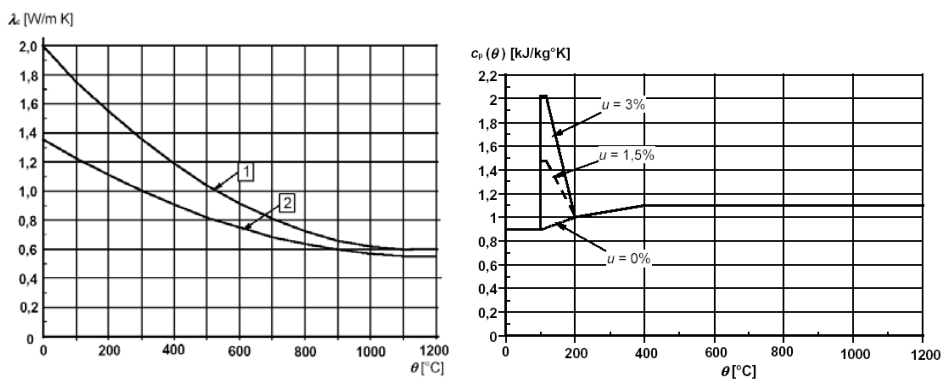

Fig. 3 - The thermal conductivity (3a) and specific heat(3b) of concrete according to Eurocode 2 part 1-2 [9].

2. Experimental procedure

2.1 Test method

The basic idea behind the TPS method is to apply a constant heating effect and measure the temperature response in the same sensor.

When a measurement according to the TPS method is performed a flat round hot disc sensor is placed between two pieces of material, see Fig. 4. The sensor consists of a thin nickel foil spiral, 10 μm , which is sandwiched between two sheets of electrical insulation material. When the temperature is below 500 K the insulation material is Kapton with a thickness of 25 μm and in the 500 – 1000 K range Mica with the thickness of 60 μm is used. The reason for using Nickel as the conducting material in the sensor is because of its large temperature coefficient of resistivity over a big temperature range.

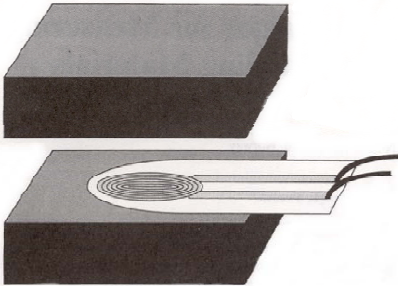

Fig. 4 - The test setup for a measurement according to the TPS method [11].

The hot disc sensor in Fig. 4 acts as a constant effect generator and a resistance thermometer at the same time. The time dependant resistance rise is recorded and converted with the temperature coefficient of resistivity for Nickel to a temperature response curve. When a constant electrical effect is applied the temperature in the sensor rises and heat starts to flow to the tested material. The temperature rise in the sensor is then a direct response of the thermal properties of the tested material. Depending of the thermal properties a proper applied effect, size of sensor and measurement time must be chosen, i.e. it is an iterative process if the properties of the tested material are totally unknown. The effect selection is direct connected to the desired temperature rise in the test specimen. For metals a suitable temperature rise is $< 1\text{ }^{\circ}\text{C}$ and for insulation materials between approximately 1 and $5\text{ }^{\circ}\text{C}$. There is a characteristic time for every measurement when the thermal conductivity, thermal diffusivity and the specific heat can be determined from one measurement. This is when the heat profile in the test specimen can be approximated as a mix of the mathematical solutions from a semi-infinite slab and a point source. If the measurement time is too short only the thermal effusivity can be calculated because the mathematical solution approaches the semi-infinite slab case. If the measurement time on the other hand is too long the mathematic solution is more like an infinite solid heated by a constant point source and only the thermal conductivity can be calculated [11,12]. A more

detailed mathematical description of the solution strategy used in the software Gustafsson [12] gives.

When measurements are made with the TPS method the test specimen must have a uniform internal temperature distribution. A temperature drift recording that is the start-up for every measurement checks this. If the temperature recording show a systematic drift in any direction there is a possibility to compensate for that in the software but the accuracy of the measurement can be suffering and therefore it is not recommended. The measurements at high temperatures in this project have been performed inside a muffle furnace.

All the measurements presented in this article are a result of at least three repeated measurements with the same experimental setup. This is done to assure that no time dependant processes in the material are going on, and to detect if any external random errors occur.

2.2 Tested material

One quality of self-compacting concrete with polypropylene fibres has been studied. This type of concrete does not require vibrating when it is cast in a mould. To the concrete recipe a small amount of polypropylene fibres were added with the purpose to avoid or reduce the possibility of spalling when the concrete is exposed to fire. The recipe for the concrete is shown in Table 1. All the thermal property measurements on concrete described in this article were done on dried material.

Table 1 - Concrete mixture [13].

Dry materials (kg/m ³)		
Cement	Slite (CEM I)	380.76
Limestone filler	Limus 25	119.24
Fine gravel	0-8 Sätertorp	899.96
Coarse gravel	8-16 Sätertorp	721.90
Plasticizer*	CemFlux Prefab	5.73
Plasticizer	(% of C+F)	1.15%
Fibres	Fibrin 18µm	1.0
Water/moisture (kg/m ³)		
Water		149.69
Dilution water		10.02
Moisture in material		37.54
w/c-ratio		0.518

* Plasticizers are given as weight in diluted form, as delivered. The moisture is included in "Moisture in material" in the table.

3. Test Results

The temperature sequence for the test on concrete was chosen to be 20, 90, 110, 200, 500, 600, 500, 200 and 20 °C. The decrease of the temperature from 600 to 20 °C was done to see if the thermal conductivity was to remain constant during cooling as reported in the literature [1]. At every temperature level the measurement was performed when the test sample had a uniform temperature distribution. In Fig. 5, the thermal conductivity from the measurements is presented and in Fig. 6 the thermal diffusivity is shown. As explained earlier the thermal conductivity, thermal diffusivity and the specific heat are determined simultaneously i.e. in the same measurement.

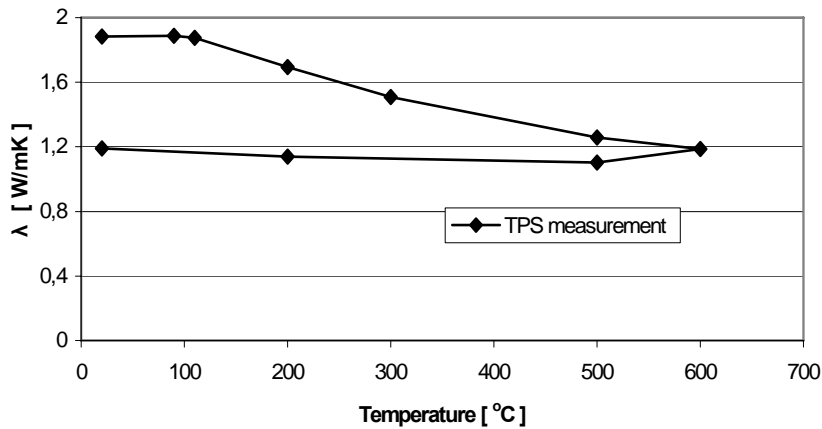

Fig. 5 - The thermal conductivity for the tested concrete at different temperatures and place in the heating cycle. The heating cycle starts at the highest conductivity value at 20 °C

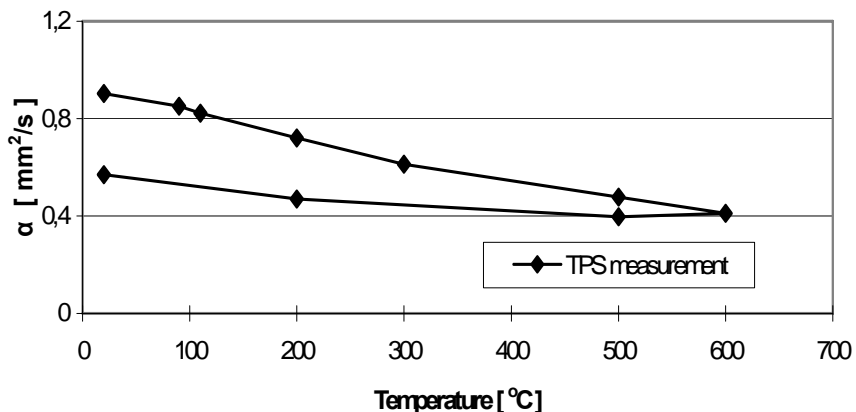

Fig. 6 - The thermal diffusivity for the tested concrete at different temperatures and place in the heating cycle. The heating cycle starts at the highest diffusivity value at 20 °C.

To get some kind of accuracy check on the measurements done with the TPS equipment a supplementary test on the concrete was done with a MDSC (Modulated Differential Scanning Calorimeter) to determine the specific heat. In Fig. 7 the specific heat results from the TPS test and two scanning tests are shown.

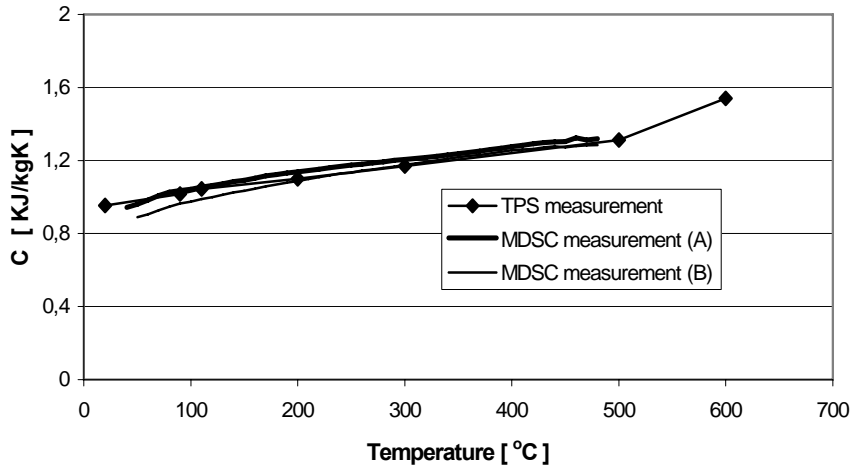

Fig. 7 - The specific heat of the investigated concrete. The volumetric values from the TPS measurements are converted to the right unity with the temperature dependant density taken from the Eurocode 2 part 1-2 [9].

4. Discussion

Concrete is a mixture of aggregate and cement paste. The thermal conductivity in the aggregate is normally higher than in the paste so it is important to use a sensor of a suitable size to get a representative picture of the material. This was checked by MDSC (Modulated Differential Scanning Calorimeter) measurements on pulverized material. From this measurement a representative value of the specific heat can be achieved. The specific heat measurements done with the TPS agreed well with MDSC, see Fig. 7.

A fire test on self-compacting concrete slabs made with the same recipe as the concrete tested with the TPS equipment was performed with an ISO 834 exposure. The dimensions of the specimen were 200 x 1200 x 1800 mm (thickness x width x length) [13]. Inside the specimen the temperature was recorded at the depths 10, 25, 50, 100 mm from the fire-exposed surface. The measured temperature at the depth 10 mm, $T_m(10\text{ mm})$, was then used as boundary condition in an one-dimensional finite element calculation. The finite element code TASEF [14] was used for the calculation and the thermal properties from the TPS measurements were used as input.

The thermal data from the TPS measurements on dried concrete shown in Fig. 5 and 7 were completed with data for the latent heat corresponding to the moisture content measurements that were done prior to the fire test on the concrete plates. The moisture content in the concrete was 4,8 % and both the amount of energy that was needed for heating the water up to 100 °C and latent heat was added in the simulation model. The effect of latent heat of evaporation was spread out between 100 and 150 °C.

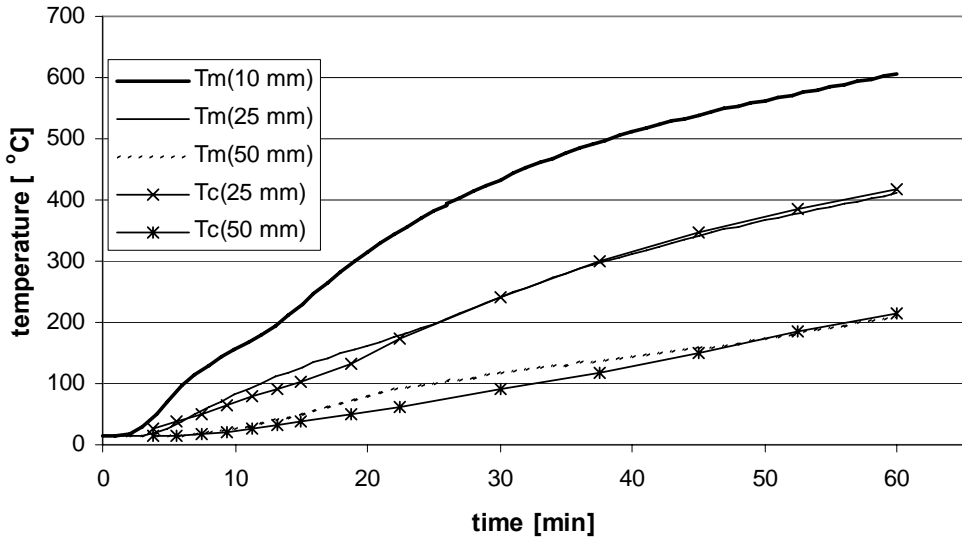

Fig. 8 - Temperature curves from the measurement, Tm = temperature measurement, Tc = temperature calculation.

The calculated temperature response, Tc, shown in Fig. 8 shows a good agreement with temperature measurements Tm. The only significant difference is in the 100 °C region which is probably caused by moisture movements or/and pressure dependant boiling points.

5. Conclusions

With the TPS (Transient Plane Source) method the thermal conductivity, thermal diffusivity and the specific heat can be determined at the same time.

The thermal data at elevated temperatures from the TPS (Transient Plane Source) measurements on self-compacting concrete correspond well with data from specific heat measurements done with MDSC (Modulated Differential Scanning Calorimeter). A good correlation in a practical case has been shown between a finite difference calculation based on TPS data and temperature measurements on a full-scale fire test object.

References

- [1] Ödeen, K. & Nordström, Å., *Termiska egenskaper hos betong vid höga temperaturer* Statens Provningsanstalt, Brandtekniska Laboratoriet 1972:1
- [2] *Properties of Materials at High Temperatures Concrete* Rilem committee 44-PHT June 1985, Edited by U. Schneider
- [3] Flynn D. R. *Response of High Performance Concrete to Fire Conditions: Review of Thermal Property Data and Measurement Techniques* Metsys Report No. 98-01-101 December 1998, NIST
- [4] Bažant Z. P., Kaplan M. F. *Concrete at High Temperatures: Material Properties and Mathematical Models* Longman (Addison-Wesley), London, 1996
- [5] Ödeen K. *Fire Resistance of Prestressed Concrete Double T Units* National Swedish Institute of Material Testing, 1968
- [6] Collet Y., Tavernier E. *Etude des propriétés du béton soumis à des températures élevées. Comportement du Matériaux Beton en Fonction de la Temperature*, Groupe de Travail, Brussels, November 1976
- [7] Harmathy T. Z., Allen L. W., *Thermal properties of selected masonry unit concretes* Journ. Amer. Concr. Inst., 70(2), pp. 132-42, 1973
- [8] Hildebrand G., Peeks M., Skokan A., Reimann M. *Untersuchung der Wechselwirkung von Kernshmelze und Reaktorbeton* Research Paper BMFT RS 154, May 1978, Erlangen
- [9] Eurocode 2: Design of concrete structures - Part 1-2: General rules - Structural fire design, prEN 1992-1-2, final draft, December 2003
- [10] Instruction Manual, Hot Disk Constants Analyser, Version 5
- [11] Gustafsson, S.E. & Long, T., *Transient Plane Source (TPS) Technique for Measuring Thermal Properties of Building Materials*, Fire and Material, Vol. 19, 1995, pp. 43-49.
- [12] Gustafsson, S.E., *Transient Plane Source (TPS) Technique for Thermal Conductivity and Thermal Diffusivity Measurements of Solid Materials*, Rev. Sci.

Instrum, 62(3),1991, pp 797-804

- [13] Boström L, *Innovative self-compacting concrete-Development of test methodology for determination of fore spalling*, SP report 2004:06, Sweden 2004
- [14] Wickström U., *TASEF User's Manual*, Swedish National Testing and Research Institute, Sweden 1989

Publication II. Jansson R. "Liquid/steam pressure measurement inside concrete exposed to fire" Proceedings from the 4th international workshop Structures in Fire, Aveiro, Portugal, 2006

Liquid/steam pressure measurement inside concrete exposed to fire

ROBERT JANSSON¹

ABSTRACT

In order to investigate the mechanism of fire spalling, and obtain experimental data on the liquid/steam pore pressure inside concrete exposed to fire, a pressure measurement system containing oil as the pressure carrier has been used.

The liquid/steam pressure inside a fire tested self compacting concrete was measured at different ages, load levels and specimen sizes. The results do not show any clear relationship between age and pressure development in the fire situation. A conclusion from the tests performed is that it is unlikely that the pore pressure is the main reason for fire spalling of the investigated concrete.

1. INTRODUCTION

The high density and the thermal properties of concrete are advantageous when concrete is exposed to fire. Heat transport is in most cases a slow and well known process which depends largely on the aggregate that is used and the concrete quality [1]-[3]. The slow nature of this process leads to the formation of a very steep temperature gradient in the concrete element exposed to the fire, especially in the early stages of exposure to a flashed over fire. Therefore, the temperature dependant degradation of the material is limited to a relatively thin layer which grows slowly with the time of exposure. This makes the explosive spalling of the concrete, which occurs under certain circumstances, particularly onerous to the fire resistance, as the advantageous insulation function of the outer material is lost. In certain specific instances the whole cross-section may collapse.

Fire spalling is a poorly understood phenomenon that occurs due a complex interplay between numerous parameters in the material and/or structure. Some of the main factors that are known to influence the risk of fire spalling are the moisture level, aggregate type, permeability, cross section and speed of heating. For the past 40 years or more, two main

¹ Project manager, PhD-student, Fire Resistance, Swedish National Testing and Research Institute, Fire Technology, email: robert.jansson@sp.se

theories have traditionally been used to explain the origin of fire spalling of concrete, i.e., thermally triggered forces and steam pressure from the water present in the concrete.

In 1965, Harmathy [4], [5] presented a theory that explained spalling as a moisture phenomenon i.e. moisture clog spalling. Concrete is a porous material and, according to this explanation, desorption of water in the early stages of fire exposure starts when heat begins to penetrate the concrete. A major part of the desorbed vapour then moves to colder regions of the concrete and is adsorbed into the colder concrete matrix. When the drying front moves further into the concrete, this phenomena leads to the formation of a fully saturated layer in front of the vapour, a so called moisture clog. This moisture clog acts as an obstruction to the vapour and the vapour is forced to find release through the fire exposed side of the concrete. Finally, at some point in time, as the heat increases, the hot side of the moisture clog itself will begin to evaporate and the steam pressure will begin to rise. Indeed, the formation of a moisture clog where the concrete matrix is saturated with liquid is supported by fire test data as in many cases when concrete is fire tested with a single side of exposure, liquid water can be seen, literally pouring out of the non-exposed side, as illustrated in figure 1.



Fig. 1 Liquid water on the non-(fire)-exposed side of 200 mm thick concrete slabs.

The other explanation, presented for example by Bazant [6], relates to “brittle fracture and delamination buckling caused by compressive biaxial thermal stresses parallel to the heated surface”. Bazant also point out the moisture clog alone cannot cause spalling. When a crack, produced by pore pressure, starts to open, the available volume for the water vapour and liquid increases drastically and the pressure drops. Thus, Bazant [6] concluded that the pore pressure can only act as a trigger for the spalling phenomenon. Once the pore pressure has triggered the crack, its growth and the resulting explosive spalling will depend on the thermal stresses.

These theories point out that the internal pressure of water and vapour in any concrete element is an important factor in understanding the phenomenon of explosive spalling. Several models have been developed to describe the underlying physics of heat and mass transfer (sometimes coupled to mechanical properties) of concrete at high temperatures [7]-

[9]. Indeed, in recent years, developments in computational capacity and numerical codes have lead to the construction of more and more refined, constitutive relations between the properties of matter in concrete. In light of this, there is a need for more experimental data for the validation of these models. Therefore, measurements of the internal liquid/steam pressure in concrete exposed to fire, such as those presented in this paper, are of fundamental interest.

2. EXPERIMENTAL DESCRIPTION

2.1 Pressure measurement

A variety of methods used to measure the pressure inside heated concrete can be found [10]-[15]. Direct measurements with embedded electrical sensors have been conducted by Phan [10], Consolatio et al. [11] and Dal Pont and Ehrlacher [12]. One problem with this type of measurement is the size effect, i.e., the size of the sensor must be small to minimize the influence of the sensor on the thermal field in the concrete. Further, the temperature range where the pressure sensor is functional can be a limiting factor. Naturally, sophisticated pressure gauges can be used which have a broad temperature range but no such sensors exist that can survive a standard fire test. The fact that pressure gauges in these type of tests are sacrificial are limiting their use in extensive test programs.

Indirect measurement can also be used. In this approach the pressure is conducted out of the specimen in a small pipe so that the pressure can be measured outside of the sample. In this case the pipe is open ended with one end inserted into the sample and the other end connected to the external pressure gauge. This is a more cost effective method of measurement because the pressure sensor can be reused and the working conditions for the sensor are more stable. The actual measurement can be made as a vapour pressure measurement, using an empty pipe [13], [14]; or as a fluid pressure measurement, using oil as the pressure conductor [15].

In the experiments presented in this paper, oil has been used as the pressure carrier. The advantage of oil as a pressure carrier is largely due to its minimal compressibility. The disadvantage of using oil, however, is that oil is subject to thermal expansion in the pipe when exposed to elevated temperatures. This thermal expansion could potentially be misinterpreted as a pressure rise. Preliminary investigations of the effect of such expansion on the pressure measurements in experiments, in which the concrete is exposed to an ISO 834 curve, indicate that this effect will be minimal. This is due to the fact that the ISO 834 curve will give rise to high temperature gradients in the concrete, and only the top of the oil filled pipe will be heated in the initial stages of the fire exposure. As the main purpose of these measurements is to measure the pressure up to the point of first explosive spalling, it is expected that this method will provide sufficiently accurate results up to this point. A simple experiment where 5 cm of a plugged oil pipe was exposed to an environment at 200 °C, indicates that the thermal expansion is in an acceptable range, i.e. only a minor overestimation of the pressure will be made with this system.

2.2 Test setup

During casting of the concrete test specimens, thin steel pipes with an inner diameter of 2 mm and wall thickness of 0.2 mm were inserted into the concrete, see figure 2. One end of each steel pipe was placed near the surface to be fire tested. The pipe extended from the measurement point through the test specimen, exiting on the cold side. To ensure that no concrete, i.e. cement paste, would fill the pipes, thin welding bars were inserted into the pipes

during casting. Figure 2 shows a pressure measurement station with three steel pipes and one thermocouple. The struts placed at each of the four corners of the measurement station are used to position the whole apparatus correctly in the concrete specimen. The steel pipes are (from left to right) 10, 20 and 30 mm shorter than the four struts. This setup is then placed in the casting mould with the struts placed on the surface which is to be exposed to the fire, ensuring that each pressure measurement is made 10, 20 and 30 mm from the surface exposed to fire.

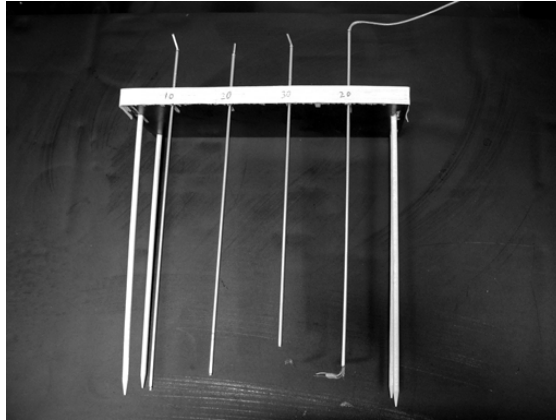

Fig. 2 The oil pipes and one thermocouple

When the fire tests were conducted the welding bars inside the steel pipes were removed and the pipes were filled with high temperature silicone oil, Sil 300, produced by Haake. Filling of the pipes was conducted by inserting a thin injection needle and carefully injecting oil from the bottom of the pipe to ensure that no air was trapped. Outside the concrete the steel pipes were connected to a pressure gauge using a T-junction (see Figure 3). The pressure gauges that were used were of the type P8AP/100bar from Hottinger Baldwin Messtechnik GmbH.

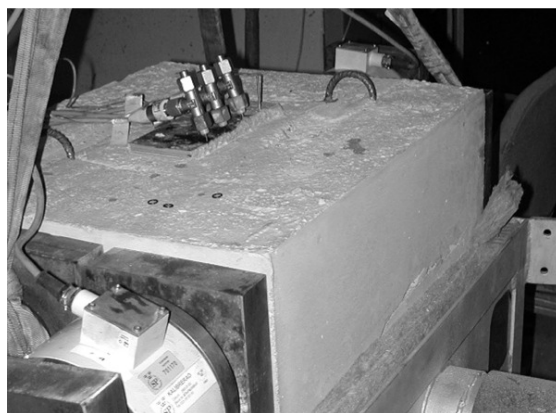

Fig. 3 The pressure gauges connected to the small pipes with angle tees.

Two sizes of test specimens were used in this experimental series: concrete slabs with dimensions $600 \times 500 \times 200 \text{ mm}^3$ and $1800 \times 1200 \times 200 \text{ mm}^3$. All specimens were equipped

with both pressure gauges and type K thermocouples. Each specimen was equipped with thermocouples at a minimum of 3 different depths: 10, 20 and 40 mm in the small slabs and 10, 20, 25, 40, 80 and 120 mm in the larger test slabs.

The small slabs were tested on a small scale furnace with an opening area of 500 x 400 mm². During most of the tests a compressive load was applied with a loading system consisting of 36 mm post tensioning bars inside aluminium pipes. Load cells were applied to measure the load during the test. One such load cell can be seen in the left hand corner of figure 3. The large slabs were tested on the horizontal furnace with an opening area 3 x 5 m², with the same type of loading system as the small slabs. The test on the horizontal furnace was made in accordance with EN 1363-1 which means that plate thermometers were used to control the furnace temperature. The use of type K thermocouples during the test on the small furnace and plate thermometers on the horizontal furnace made the thermal exposure somewhat different. Thus, the large slabs tested according to the EN 1363-1 standard experienced a slightly higher thermal exposure.

2.3 Test specimens

The material used in these tests was self-compacting concrete with limestone filler. All test specimens were produced at the same time and stored in indoor climate before the fire tests. More details of the composition and properties are shown in table 1.

Table 1 - Concrete admixtures and characteristics.

Water	230
Cement (CEM II)	355
Limestone filler (Limus 25)	105
Plasticizer (Sikament 20HE)	2,4
Stabilizer (Sika Stabilizer 100)	4,0
Aggregate 0-8 mm	1029
Aggregate 8-16 mm	554
w/c	0,65
w/p	0,50
Air (%)	1,8
Slump	620
Compressive strength (28 days)	37
Moisture (% , 3 month old)	5.3
Moisture (% , 6 month old)	5.0

The name of the test specimens is for example “A, 3 month, 5%”. This means Specimen A tested at the age 3 month with an external load level of 5 % of the compressive strength. The A and B letters are used when two equal tests have been carried through. All the load levels refer to the strength at 3 month, which was 39,4 MPa.

3. RESULTS

The temperatures measurements from a typical test specimen tested on the small furnace during 60 minutes are shown in figure 4. This test specimen, which was tested with a load level of 5 % of the ultimate compressive strength at 3 months, started to spall after 16 minutes. Figure 5 shows the size of some of the first material spalled off in these test. The sound of the spalling in these experiments is a mix of loud bangs and quiet plops. Further results and discussion focussing on the amount of spalling, can be found in the article “Spalling of self compacting concrete” by Boström and Jansson also presented at this workshop.

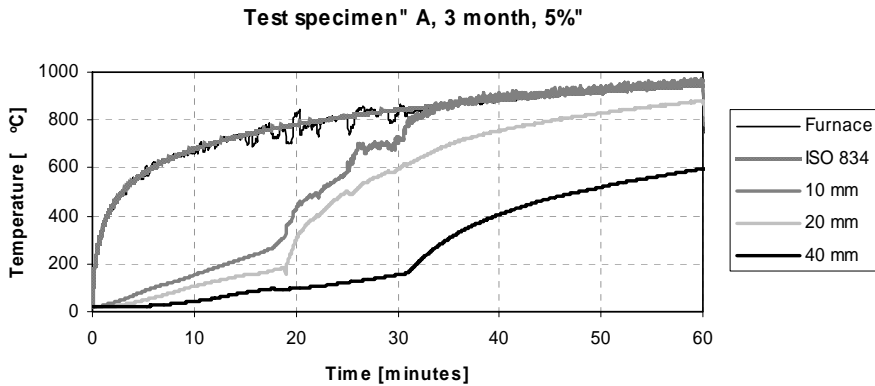

Fig. 4 Temperature vs. time for a test specimen tested using the small furnace. This specimen started to spall at 16 minutes.



Fig. 5 This is some of the material spalled of form specimen “A, 3 month, 5%”.

To obtain a clearer picture, all graphs from pressure measurements shown in this report show the pressure development until the time of the first spalling, which means that when the pressure curve is ended, spalling has occurred. In figure 6 the measured pressures at the depth of 10 mm are shown, for concrete of different ages. The plot shows the pressure development to the time of spalling. Of the specimens tested, two did not spall during the fire tests: “B, 6 month, 0%” and “B, 3 month, 10%”. All other specimens did spall.

Pressure at 10 mm, small scale tests

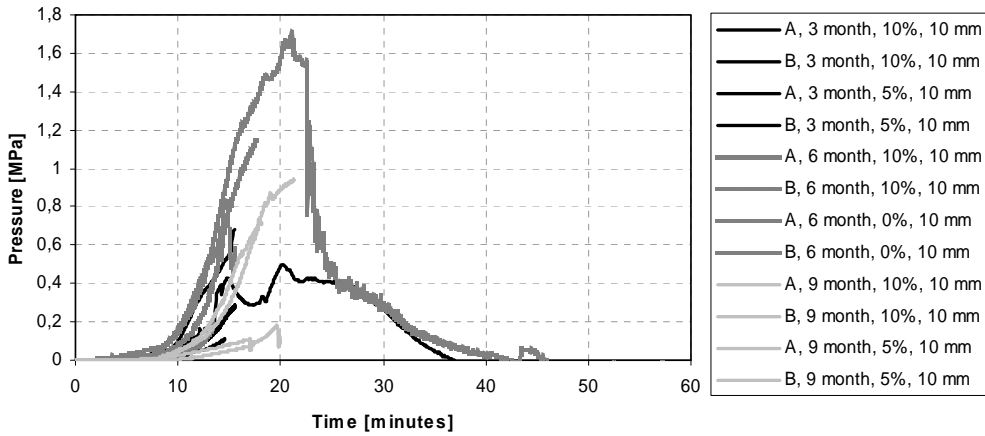

Fig. 6 Pressure vs. time at different ages for the measurements at the depth of 10 mm.

The measured pressures at the depth of 20 mm are shown in figure 7. Note that in this figure the pressure in specimen “B, 3 month, 10 %” rises rapidly. The pressure is actually higher than all other of the measurements at the depth of 10 mm.

Pressure at 20 mm, small scale tests

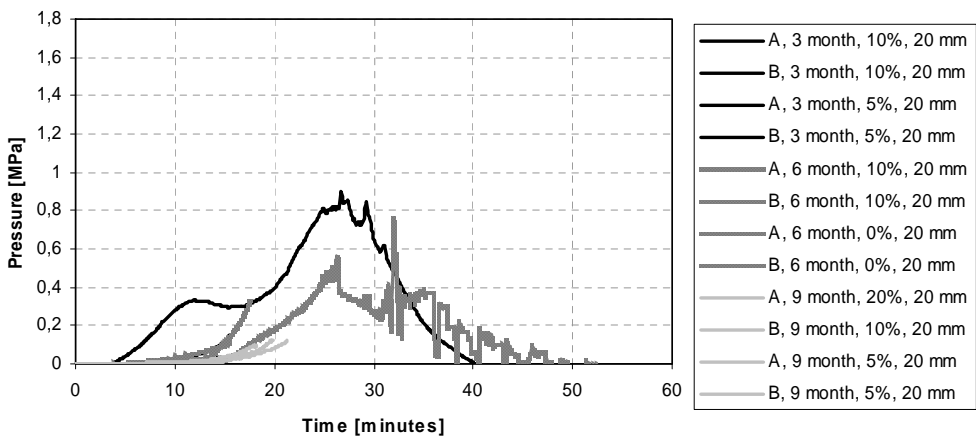

Fig. 7 Pressure vs. time at different ages for the measurements at the depth 20 mm.

At the depth of 30 mm only small pressures were built up before the spalling occurred, see figure 8. The highest pressure was measured in specimen “B, 3 month, 10 %”, as found at the depth of 20 mm.

Pressure at 30 mm, small scale tests

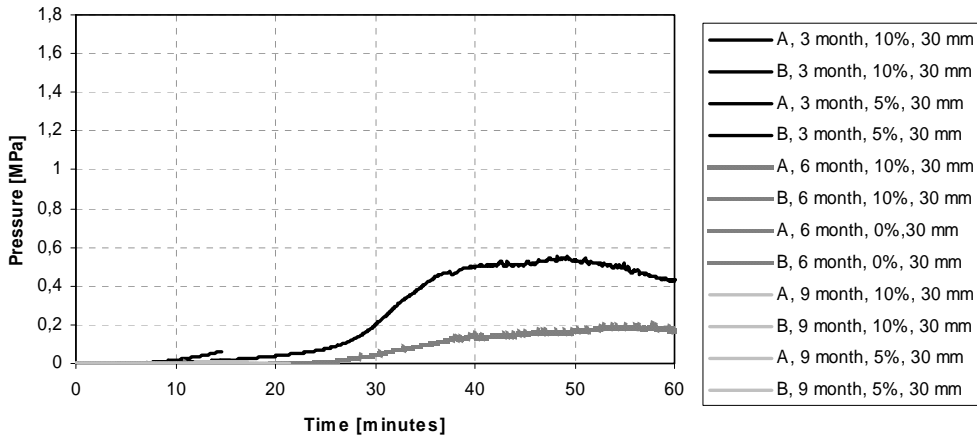

Fig. 8 Pressure vs. time at different ages for the measurements at the depth 30 mm.

Pressure measurements were also conducted during tests of large slabs of the same quality of concrete, on the horizontal furnace. Four large slabs were tested with pressure measurements being taken at depths of 10, 20, 30, 40 and 50 mm. During these tests, two of the slabs were loaded in compression with 10% of the 3 month compressive strength and two slabs were unloaded. During these tests the concrete started to spall after 10 minutes and during that time the highest pressure recorded in one of the 20 pressure gauges was 0.3 MPa. Due to limited space in this article and the fact that these results provide no further insight into the discussion below, graphical results are not presented here.

4. DISCUSSION AND CONCLUSIONS

A self compacting concrete was tested at different ages, 3, 6 and 9 month, and load levels, 0, 5 and 10 % of the compressive strength at 3 month, on a small scale furnace. The results do not show any clear relationship between the age and the pressure development in the fire exposed concrete. The highest pressure measured, 1.8 MPa, was at the depth of 10 mm, in a specimen that was not spalling. All of the specimens, but two, spalled when they were exposed to an ISO 834 curve.

Previous tests have provided results in the same range of pressures as those presented in this paper. As a comparison, even though the concrete mixes and the placement of the pressure gauges are different, experiments conducted by Harada and Terai [15] with ISO 834 thermal exposure resulted in a maximum pressure of 0.2 MPa. Similarly, in the experiments conducted by Kusterle et al. [14], with the extremely tough LT1 “Lainz 180” temperature curve, the maximum pressure measured was 1 MPa. The highest pressures recorded in tests of this type on concrete have been made by Phan [10] who measured 2.1 MPa in moist, cured, high strength concrete cylinders that spalled.

The maximum pressure measured, in the tests presented here, before spalling is low compared to the normal tensile strength of concrete. This supports the explanation for explosive spalling that Bazant [6] has proposed, i.e., that the pore pressure alone cannot cause explosive spalling. If the pore pressure is involved, the role may be only as a trigger, i.e. the

pressure leads to a slight deformation that initiates the process of thermal stress promoted brittle fracture. This conclusion is further supported by the fact that, although the concrete exhibited significant spalling, the maximum pressure recorded during the large scale test on the horizontal furnace was only 0.3 MPa. The obvious conclusion to be drawn from this fact is that the pore pressure cannot be the sole explanation for the spalling behaviour seen in the concrete investigated, and may not even be an important factor.

The results presented in this paper give no definitive proof of the role of pore pressure (or indeed, whether there is any role) in the spalling of concrete. Before general conclusions can be drawn concerning spalling behaviour in concrete, further results are needed from other concrete mixes and geometries. Such tests will be the subject of future work.

References

- [1] Eurocode 2: Design of concrete structures - Part 1-2: General rules - Structural fire design, prEN 1992-1-2, final draft, December 2003
- [2] Flynn D. R., "Response of High Performance Concrete to Fire Conditions: Review of Thermal Property Data and Measurement Techniques", Metsys Report No. 98-01-101 December 1998, NIST
- [3] Jansson R., "Measurement of Concrete Thermal Properties at High Temperature" Proceedings of FIB Task Group 4.3 Workshop, Fire Design of Concrete Structures: What now? What next?, Milan, Italy, pp 101-107, 2004
- [4] Harmathy, T. Z., "Effect of moisture on the fire endurance of building materials", Moisture in Materials in Relation to Fire Tests, ASTM Special Technical Publication No. 385, pp 74-95, 1965
- [5] Harmathy, T. Z., "Fire Safety Design & Concrete", Concrete Design & Construction Series, Longman Group UK Limited pp. 1-412, 1993
- [6] Bazant, Z. P., "Concrete Creep at High Temperature and its Interaction with Fracture: Recent Progress", Concreep-7 Conference: Creep, Shrinkage and Durability of Concrete and Concrete Structures, pp 449-460, 2005
- [7] Tenchev R. , Purnell P., "An application of a damage constitutive model to concrete at high temperature and prediction of spalling" International Journal of Solids and Structures 42 (2005) 6550–6565
- [8] Gawin D., Pesavento F., Schrefler B. A., "Modelling of hygro-thermal behaviour of concrete at high temperature with thermo-chemical and mechanical material degradation" Comput. Methods Appl. Mech. Engrg. 192 (2003) 1731–1771
- [9] Alnajim A., "Modelisation et simulation du comportement du beton sous hautes temperatures par une approche thermo-hygro-mecanique couplee. Application a des situations accidentelles." PhD thesis, Universite de Marne la Vallee U.F.R de Sciences et Technologies, pp. 1-183, 2004

- [10] Phan T. L., “High-Strength Concrete at High Temperature – An Overview” Utilization of High Strength/High Performance Concrete, 6th International Symposium. Proceedings. Volume 1. June 2002, Leipzig, Germany, König, G.; Dehn, F.; Faust, T., Editor(s), 501-518 pp, 2002.
- [11] Consolazio, G. R.; McVay, M. C.; Rish, J. W., “Measurement and Prediction of Pore Pressure in Cement Mortar Subjected to Elevated Temperature” NIST SP 919; September 1997. International Workshop on Fire Performance of High-Strength Concrete. Proceedings, pp.125-148, 1997.
- [12] Dal Pont S., Ehrlacher A., “Numerical and experimental analysis of chemical dehydration, heat and mass transfers in a concrete hollow cylinder submitted to high temperatures” International Journal of Heat and Mass Transfer 47 (2004) pp. 135–147
- [13] Kalifa P., Menneteau F.D., Quenard D., “Spalling and pore pressure in HPC at high temperatures” Cement and Concrete Research 30 (2000) pp.1915-1927
- [14] Kusterle W. et al. “Brandbeständigkeit von Faser-, Stahl- und Spannbeton” Heft 544, Bundesministerium für Verkehr, Innovation und Technologie, Wien, pp.1-221, 2004
- [15] Harada, K.; Terai, T., “Heat and Mass Transfer in the Walls Subjected to Fire”, U.S./Japan Government Cooperative Program on Natural Resources (UJNR). Fire Research and Safety. 13th Joint Panel Meeting. Volume 1. March 13-20, 1996, Gaithersburg, MD, Beall, K. A., Editor(s), pp 423-435, 1997.

III

Publication III. Jansson R. Boström L. "Fire spalling: Theories and experiments" Proceedings from the fifth International RILEM Symposium on Self-Compacting Concrete, 3-5 September 2007, Ghent, Belgium

FIRE SPALLING: THEORIES AND EXPERIMENTS

Robert Jansson and Lars Boström

SP Technical Research Institute of Sweden, Dept of Fire Technology, Borås, Sweden

Abstract

Fire spalling can be described as the breaking off of small or large layers or pieces of concrete from the surface during fire exposure. In some rare cases spalling can refer to the explosion of a whole cross-section or the division of an entire concrete element. Numerous mechanisms have been defined to explain fire spalling and there has been some controversy concerning the correct mode of action to produce spalling. It is clear that a combination of physical, thermodynamic and chemical mechanisms are involved and the underlying mechanisms are probably case dependant.

This paper will present the most common theories of spalling together with some evidence to support or refute modes of spalling operation. The spalling considered in this paper is the type that occurs between 3-30 minutes from the start of fire exposure. Non-violent degeneration of concrete during later phases of the fire is not examined.

1. INTRODUCTION

Fire spalling can be described as the disintegration or failure of concrete when it is exposed to fire. When spalling occurs it can vary in magnitude between small flakes of a few mm of the surface layer to a total explosion of, for example, the web of an I-beam. The spalling considered in this paper is the type that occurs between 3-30 minutes from the start of fire exposure. Non-violent degeneration of concrete during the later phases of a fire is not examined.

One of the earliest descriptions of fire spalling of concrete was made in 1854 when it was determined that concrete with flint aggregate would exhibit the following behaviour: “if there were flintstones in it the concrete would split, and yield under the action of fire” [1]. The first systematic attempt to categorise different kinds of fire spalling was made by Gary [2] 1910-16. He found, from fire tests on specially built houses, that fire spalling could occur in the following forms:

- *Aggregate spalling*- crater formed spalling attributed to the mineralogical character of the aggregate,
- *Surface spalling* – disc shaped violent flaking, especially in pressure stressed walls, probably caused by water damp,
- *Corner spalling* – violent spalling of corners (by later researchers [3] described as non violent), probably caused by water damp as well as temperature stresses due to bilateral fast heating up, and
- *Explosive spalling* – very violent spalling of large, up to 1 m², pieces from walls. Some pieces were thrown away 12 meter by the force. Gary [2] had no explanation for this type of spalling.

The above categorisation of spalling, with a few small modifications, has been adopted by the research community since its inception. One major addition is that *progressive spalling* can sometimes occur, where layer after layer is flaked away from the surface.

One might reasonably consider how common fire spalling is. In an inquiry made by The Concrete Society Committee of Fire Resistance [4], over 80% of the nearly 100 fire accidents reported mentioned the occurrence of fire spalling. An important conclusion from the study was that none of the investigated events led to collapse of the structure. Fire investigations at SP [5], on fires under concrete road bridges also show that while surface spalling is common on fire exposed old concrete, none of the bridges investigated were close to collapse.

To the best of the author's knowledge, a thorough compilation of the structural damage from fires in buildings focussing on the function of self-compacting concrete (SCC) or high performance concrete (HPC) has not been conducted, perhaps due to the relative infrequency of fires. Several examples of severe spalling of HPC in tunnel fires have, however, been reported [3]. Perhaps the most notable example concerns the effect of the fire in the Channel Tunnel in 1996. In some areas during that fire, the whole concrete cross-section of the 110 MPa HPC was spalled away so the grout was exposed. Similarly, up to 68% of the cross section of the 76 MPa HPC in the Great Belt tunnel was destroyed by fire spalling during a fire in 1994.

2. COMMON FIRE SPALLING THEORIES

The two most common explanations of the origin of spalling are internal pore pressures and thermal stress. Internal pore pressure caused by heating of water trapped in the concrete leads to tensile failure while restrained thermal expansion causes mechanical stresses which results in spalling. These mechanisms are both described in more detail below.

2.1 Pore pressure: vapour and hydraulic

When concrete is exposed to fire conditions, free water in the pores starts to expand. Any liquid water will start to evaporate and the steam pressure will rise rapidly. This will initiate a transport process in the porous network.

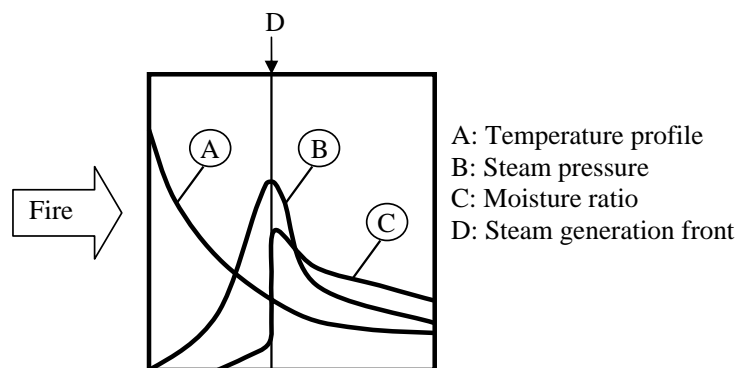

Figure 1: Schematic figure of fire exposed concrete (redrawn from ref [8]).

As the process of fire spalling usually is rapid, 3-30 minutes after the start of fire exposure, one can assume that the pressure is the main driving force (Darcian flow) for the flow [6]. This pressure will drive some of the moisture out to the fire exposed surface and some will be pressed further into the centre of the specimen. When the hot steam meets the colder inner regions of the concrete, a condensation process will begin. This can lead to the formation of a saturated region, or “moisture clog” [7], at some distance from the surface, see Figure 1. The moisture clog confines the moisture transport inwards and at a certain time a sharp, steam generation front will be created [8]. According to the moisture clog theory, a piece of the cross-section will be flaked away when the steam pressure exceeds the ultimate tensile strength of the material [7].

Another possible cause of spalling is a hydraulic fracture of a saturated pore [9-10]. According to this theory the volume expansion of the pore water in a filled pore will exceed the tensile strength of the material. Liquid water has a higher thermal expansion coefficient than the surrounding porous skeleton. If water occupies more than approximately 32 % of the initial pore volume, the water in the pore will expand during heating from room temperature to the critical point of water and fill the whole volume [9-10]. The air in the pore will be forced into solution in the water. Due to the low compressibility of water the hydraulic pressure will rise very rapidly when the temperature continues to rise in a fully saturated pore. This analysis is applicable for a closed pore system. In a real system the moisture transport will induce different boundary conditions but this mechanism might be relevant, in particular in relation to low permeability concrete.

2.2 Restrained thermal dilation

When exposed to a fire, the thermal properties [11] and the high density of concrete make it a very good insulating material. One consequence of this fact is the formation of a very steep temperature gradient inside the material. This leads to high compressive stresses near the surface caused by the restriction of the colder inner part of the concrete. As a consequence tension stress is formed in the boundary between the heated surface and the colder inner part of the concrete element. This can lead to a “brittle fracture and delamination buckling caused by compressive biaxial thermal stresses parallel to the heated surface” according to Bazant [12].

It is known from the literature that different aggregates in the concrete make it more or less prone to fire spalling [3]. The thermal expansion and the thermal properties of the aggregate seem to be an important factor.

3. EXPERIMENTAL DATA

Numerous fire experiments have been conducted on concrete elements of varying sizes and shapes and for a variety of concrete formulations and ages within the framework of two different research projects. Details of these research studies will be presented elsewhere but it is clear from numerous fire tests on SCC, that flowing liquid water can be seen on the cold side of fire exposed concrete slabs. This is a clear evidence of water movement in the concrete specimens when exposed to fire and an indication that the role of moisture (and it's movement in the concrete) is important.

However, pore pressure measurements [13] using a specially designed oil-based measurement system on SCC during fire exposure indicates only low pressures, in contradiction to simple pore pressure theories. In small scale slab tests ($500 \times 600 \times 200 \text{ mm}^3$ slabs), the maximum pressure immediately prior to spalling was 1.1 MPa at 10 mm from the fire exposed surface. Larger specimens of the same concrete ($1800 \times 1200 \times 200 \text{ mm}^3$), tested with a slightly higher thermal exposure, exhibited more severe spalling but the pressure measured at 10 mm from the fire exposed surface had a maximum of 0.3 MPa immediately prior to spalling. Significant in both cases is the fact that there were pieces of concrete, approximately 10 mm in thickness, spalled away from the test sample. Thus, based on pore pressure theory one would expect the maximum pressure to be approximately where the pressure was measured. These findings cannot, however, conclusively disprove pore pressure theory due to the technical difficulties associated with performing the measurements. Corroborative evidence should be collected and further research is under way.

Figure 2 shows temperatures at different depths in an SCC slab ($1800 \times 1200 \times 200 \text{ mm}^3$) exposed on one side to the EN 1363-1 standard fire. As seen in the figure, the temperature difference between the furnace temperature and that registered 10 mm below the surface of the material is more than 400 degrees after 10 minutes. Clearly, large thermal stresses would be created by such a large temperature difference.

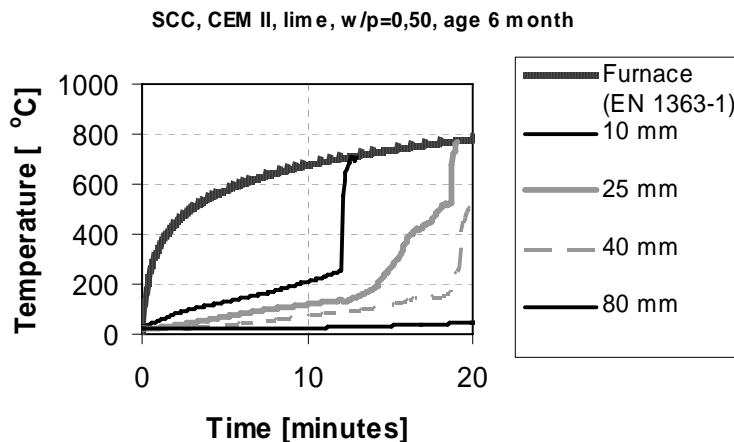

Figure 2: Temperature on different depth in a fire exposed slab tested at SP. The fire spalling started after 10 minutes.

Finally, in a comparative study between two HPC formulations [14], which differed only in terms of the type of aggregate, the influence of the thermal gradients on spalling was investigated. The microstructure and the permeability of the concretes were similar but the thermal diffusivity was drastically higher in one HPC than in the other. The high thermal diffusivity of one of the HPC led to much lower thermal gradients in the concrete element. This led in turn to absence of spalling in this sample. This indicates that thermal stresses are dominating spalling behaviour in these samples.

4.

DISCUSSION

Although there are exceptions, most empirical experience indicates that density and internal water content play key roles in the phenomenon that lead to fire spalling. One major problem facing the research community is to understand the magnitude of and nonlinear coupling between the following factors (see Figure 3):

- **Density:** Dense concrete usually exhibits low permeability which slows down the rapid drying process during a fire and traps the water inside the concrete leading to high internal vapour pressures.
- **Creep, swelling and mechanical properties:** During fire exposure of high density concrete, the restricted moisture transport and moisture status will influence the mechanical properties. In such cases, swelling and pore pressure will give an extra contribution to the thermal expansion. Drying creep releases the stresses due to expansion. Restricted moisture transport reduces the impact of such creep i.e. stresses increase. Without this creep effect, often called “transient thermal creep”, almost all concrete (with common aggregates) will fall apart at high temperature.
- **Water content:** Large water content leads to high vapour generation during heating and consequently increased internal pressure.
- **Temperature Gradients:** High water content leads to higher temperature gradients due to the latent heat of vaporisation, which in turn leads to higher thermal stresses.

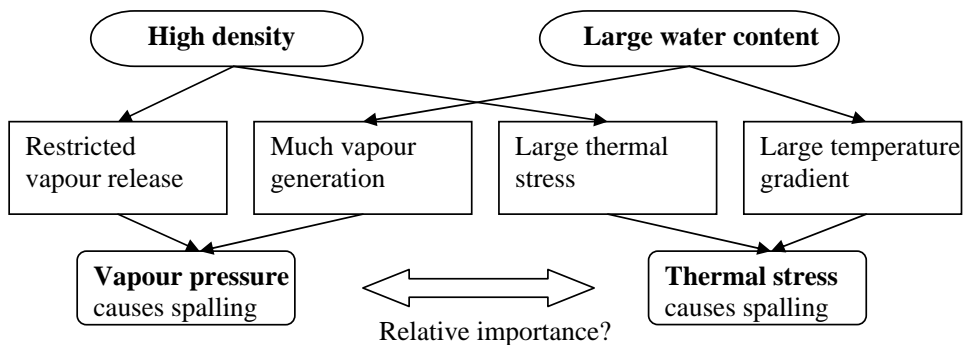

Figure 3: Relations between factors and reasons concerning spalling (redrawn of flow diagram from ref [15]).

5.

CONCLUSIONS

The experimental results presented in section 3 of this paper indicate that water content and its movement in concrete are important. Preliminary evidence from pore pressure measurements on SCC, however, indicates that the correlation between pore pressure and spalling is complex at best. Further, temperature measurements at different depths in samples

that have fire exposure on one side exhibit sharp temperature gradients which are an indication of thermal stress.

Spalling itself is a complex process that is affected by many parameters. Full understanding and prediction of these processes is not presently possible although some general predictions can be made. In order to provide a sound basis for future predictions of fire spalling more work is needed to establish sound measurement methods for physical properties. Without proper measurement techniques it will not be possible to understand the complex coupling between different modes of action in concrete leading to fire spalling.

REFERENCES

- [1] Barret "On the French and other methods of constructing iron floors", Civil Engineering and Architect's Journal, Vol XVII, 1854, pp 94
- [2] Gary, M., 'Fire tests on reinforced concrete buildings', Germany, 1917, cited in Meyer-Ottens C., 'Zur Frage der Abplatzungen an Betonbauteilen aus Normalbeton bei Brandbeanspruchung', PhD-thesis, Braunschweig, 1972.
- [3] Khoury 'Effect of fire on concrete and concrete structures', Prog. Struct. Engng Mater. 2000; 2
- [4] Malhotra H. L., 'Spalling of Concrete in Fires', Construction Industry Research and Information Association, Technical Report No. 118, London 1984.
- [5] Boström L. 'Investigation of damage to a bridge caused by a road tanker fire' Brandposten No.34 2006: 28-29
- [6] Bazant Z. P., Thonguthai W. 'Pore Pressure in Heated Concrete Walls: Theoretical Prediction', Mag. Of Conc. Research, June 1979
- [7] Harmathy, T. Z., 'Effect of moisture on the fire endurance of building materials', Moisture in Materials in Relation to Fire Tests, ASTM Special Technical Publication No. 385, pp 74-95, 1965.
- [8] Thelandersson S. 'Betongkonstruktioner vid höga temperaturer -en översikt' (in Swedish), VAST, September 1974
- [9] Khoylou N. 'Modelling of moisture migration and spalling behaviour in non-uniformly heated concrete', PhD thesis, University of London, March, 1997
- [10] Breunese A.J., Fellingner J. H. H. 'Spalling of Concrete - An Overview of Ongoing Research in the Netherlands', Workshop " Structures in Fire", Ottawa, May, 2004
- [11] Jansson R., 'Measurement of Concrete Thermal Properties at High Temperature', Proceedings of FIB Task Group 4.3 Workshop, Fire Desgn of Concrete Structures: What now? What next?, Milan, Italy, pp 101-107, 2004.
- [12] Bazant, Z. P., 'Concrete Creep at High Temperature and its Interaction with Fracture: Recent Progress', Concreep-7 Conference: Creep, Shrinkage and Durability of Concrete and Concrete Structures, pp 449-460, 2005.
- [13] Jansson R., 'Liquid/steam pressure measurement inside concrete exposed to fire', Structures in fire06, Proceedings from the 4th international workshop, Aveiro, Portugal, 2006.
- [14] Sercombe J., Galle C, Durand S, Bouniol P, 'On the Importance of Thermal Gradients in the Spalling of High-Strength Concrete' EM 2000: Forteenth Engineering Mechanics conference, Austin Texas, USA, Maj 21-22, 2000
- [15] Arita, Harada, Miyamoto 'Thermal spalling of high-performance concrete during fire' Second International Workshop « Structures in Fire » – Christchurch – March 2002

IV

Publication IV. Jansson R. Boström L. "Experimental study of the Influence of Polypropylene Fibres on Material Properties and Fire Spalling of Concrete" Proceedings from the fib Task Group 4.3 workshop "Fire Design of Concrete Structures – From Materials Modelling to Structural Performance" Coimbra, Portugal, November 8-9, 2007

EXPERIMENTAL STUDY OF THE INFLUENCE OF POLYPROPYLENE FIBRES ON MATERIAL PROPERTIES AND FIRE SPALLING OF CONCRETE



Robert Jansson *

Project manager
SP Technical Research
Institute of Sweden,
Fire Technology



Lars Boström

PhD, Manager Fire
Resistance
SP Technical Research
Institute of Sweden,
Fire Technology

Keywords: Fire spalling, polypropylene fibres, mechanical properties, pressure measurements

ABSTRACT

A study of the fire spalling behaviour of concrete has been performed. It has been shown that polypropylene fibres (PP-fibres) reduce fire spalling of the investigated concretes. From the material testing part of this project it was revealed that PP-fibres in concrete modify the drying behaviour and the capillary saturation close to the surface of the concrete, and introduce a plateau in the free thermal strain curve.

1. INTRODUCTION

A deep understanding of the physics involved in the phenomenon of fire spalling of concrete is still lacking. However, many tests have shown that polypropylene fibres (PP-fibres) reduce the damage incurred by fire significantly. The aim of the project presented in this article was to investigate the spalling behaviour of concrete containing CEM I cement in combination with various amounts and sizes of PP-fibres. The fire tests were conducted on two types of test specimens, large slabs, $1800 \times 1200 \times 300 \text{ mm}^3$, tested on a large horizontal furnace with the

* Corresponding author – SP Technical Research Institute of Sweden, Fire Technology, Box 857, Sweden. Phone.: +46 10 516 50 94, Fax: +46 33 41 77 59.
e-mail: robert.jansson@sp.se

standard fire curve (EN 1363-1) and the RWS curve; and small slabs, $500 \times 600 \times 300 \text{ mm}^3$, tested on a small furnace. Additional tests, to investigate some aspects of the material behaviour at high temperature, were also performed.

2. CONCRETE MIXES AND CONDITIONING

The preparation of the concrete was performed at the concrete mixing plant Färdig Betong AB in Borås, Sweden. Färdig Betong AB, included in The Thomas Concrete Group, is the largest ready-mix concrete supplier in Sweden. The concrete mixtures chosen for this study are typical Swedish infrastructure concretes, that have been used in tunnels in western Sweden. Further, the concrete mixes have been modified by the addition of monofilament polypropylene fibres (PP-fibres) with length 12 mm and two different diameters, see table 1.

The concrete mixes used in the project are shown in Table 1. The main parameters that were varied were: the water cement ratio, maximum aggregate size and type as well as the amount of PP-fibre addition. The names of the different mixes given in Table 1 (letters A, B etc.) will be used throughout this paper. Concrete U is a reference mix for comparison of data during material testing.

Table 1 Concrete Mixes

Series	w/c	Gravel 0-8 mm [kg/m ³]	Gravel 8-16 mm [kg/m ³]	Gravel 16-25 mm [kg/m ³]	Water [kg/m ³]	Cement CEM I [kg/m ³]	Super- plasticizer [kg/m ³]	Fiber amount [kg/m ³]	Fiber ϕ [μm]
A	0.4	852	896	-	170	426	2.98	-	-
B	0.4	847	143	767	168	420	2.73	-	-
C	0.45	871	862	-	182	405	2.43	-	-
D	0.45	880	134	772	171	380	2.28	-	-
E	0.4	852	896	-	170	426	2.98	1	18
F	0.4	847	143	767	168	420	2.73	1	18
G	0.45	871	862	-	182	405	2.43	1	18
H	0.45	880	134	772	171	380	2.28	1	18
I	0.4	852	896	-	170	426	2.98	1.5	18
J	0.4	847	143	767	168	420	2.73	1.5	18
K	0.45	871	862	-	182	405	2.43	1.5	18
L	0.45	880	134	772	171	380	2.28	1.5	18
M	0.4	852	896	-	170	426	2.98	1	32
N	0.4	847	143	767	168	420	2.73	1	32
O	0.45	871	862	-	182	405	2.43	1	32
P	0.45	880	134	772	171	380	2.28	1	32
Q	0.4	852	896	-	170	426	2.98	1.5	32
R	0.4	847	143	767	168	420	2.73	1.5	32
S	0.45	871	862	-	182	405	2.43	1.5	32
T	0.45	880	134	772	171	380	2.28	1.5	32
U	0.62	1051	881	-	192	308*	0.04	-	-

* CEM II, concrete U is a concrete used as a comparison during material testing

A petrographic analysis of the aggregate used in all concrete mixes is shown in Table 2. As seen in the table, the dominating part of the aggregate is granite.

Table 2 Petrographic analysis of aggregate

	Size 0.063-2 mm	Size 2-4 mm	Size 4-8 mm	Size 8-16 mm	Size 16-25 mm
Granite	94%	94%	97%	97%	96%
Quartz, Felspar					
Amphibolite	3%	4%	3%	2%	4%
Diabase					
Mica	2%				

All concrete specimens used for fire testing were stored under water approximately half a year and then in air for between 1 – 3 months. The climate in the laboratory corresponded to a mean temperature of 21 °C and RH 62 % during the storage of the samples in air. More details about the concrete mixes and storage can be seen in reference [1].

3. FIRE TESTS

3.1 Test Methods

One of the aims of this project was to investigate the influence of the severity of the fire on the spalling behaviour. Therefore two different fire exposures were used for the large slabs, the RWS (Rijkswaterstaat) curve and the standard fire curve, EN 1363-1. The RWS curve represents a very severe fire exposure which attempts to emulate a worst case fire scenario in a tunnel, while the standard fire curve represents the temperature development in a room exhibiting a flash over. During the tests on small slabs, the standard fire curve was used. It was not possible to use plate thermometers in the small furnace during the fire tests, but to make the temperature exposure closer to the prescribed in the standard (EN 1363-1) the small furnace was calibrated with plate thermometers prior to the tests.

During the tests on both large and small slabs a compressive load of 10 % of the compressive strength was applied in one direction on the test specimen [1]. The specimens were plain concrete. During the tests temperatures and pressures in the pore system in the cross-section of the slabs was measured and the temperature and change in load were recorded.

3.2 Moisture in concrete during fire tests

Concrete filled plastic pipes were used to represent the two sided drying of large slabs. The plastic tubes were 300 mm long, had a diameter of 45 mm and were open at both ends. They were stored under the same conditions as the large specimens that they represented. Close to the day of the fire test, the cylinders inside the plastic tubes were sliced to determine the capillary saturation profiles. The pipes with concrete were sliced into 2 cm thick slices. The size 2 cm was chosen because it was the smallest size possible due to technical constraints

associated with the slicing method chosen. The sliced test specimens were then used to determine of the degree of capillary saturation according to the method described by Hedenblad and Nilsson [3]. The results of the degree of capillary saturation measurements, shown in Figure 1, indicate that the specimens containing PP-fibres show a higher degree of capillary saturation close to the surface to be fire tested (0-20 mm). It can also be seen that close to the surface to be fire tested, the sequence from lowest to highest degree of capillary saturation is the same for those concrete types with maximum aggregate size 16 mm as for those with maximum size 25 mm. In both cases the order from lowest to highest is: concrete without PP-fibres, 1 kg 32 μ m PP-fibres, 1 kg 18 μ m PP-fibres and 1.5 kg 18 μ m PP-fibres. Almost the same order from lowest to highest was also seen when determination of the moisture content in cubes was performed, see table 3.

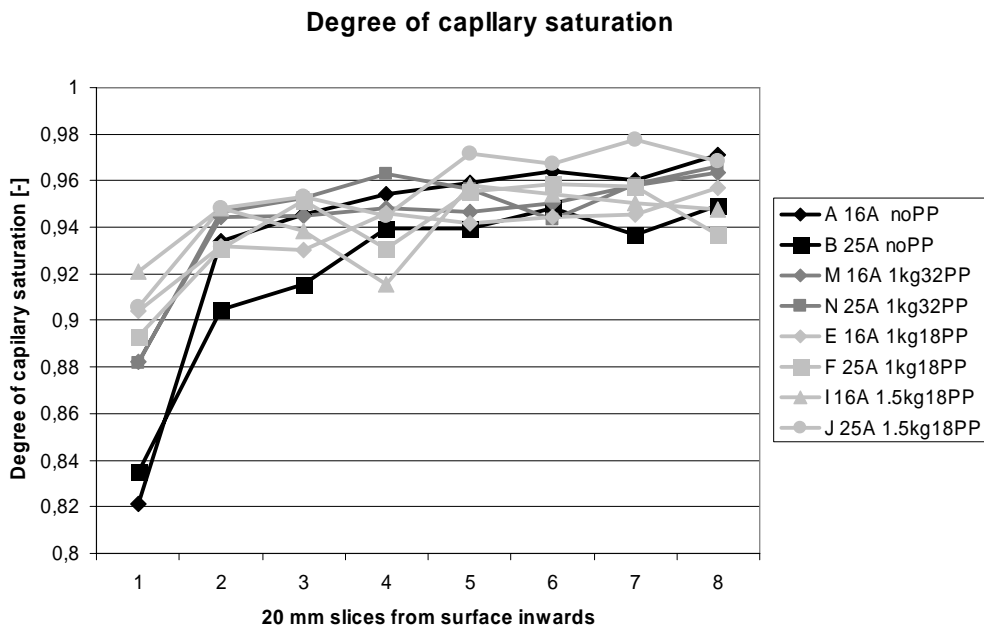

Figure 1 Degree of capillary saturation for different concretes (16 mm and 25 mm are the maximum aggregate sizes)

Table 3 Moisture content in cubes.

Max aggregate size 16 mm	Moisture content in cubes [%]	Max aggregate size 25 mm	Moisture content in cubes [%]
A	5.1	B	5.2
M (1 kg 32 μm PP-fibres)	5.8	N (1 kg 32 μm PP-fibres)	4.9
E (1 kg 18 μm PP-fibres)	6.1	F (1 kg 18 μm PP-fibres)	5.4
I (1.5 kg 18 μm PP-fibres)	5.8	J (1.5 kg 18 μm PP-fibres)	6.0

3.3 Results from fire tests

Figure 2 displays a comparison between the spalling depths in large slabs tested using the standard fire exposure curve. One should note that the concrete without addition of PP-fibres, concrete A, exhibits far greater spalling than the other types of concrete. The spalling in concrete A and F can be described as an evenly spread flaking of the specimen surface. The spalling in concrete I, M and N had another pattern, i.e., the spalling was concentrated to one part of the specimen probably through a falling off phenomenon.

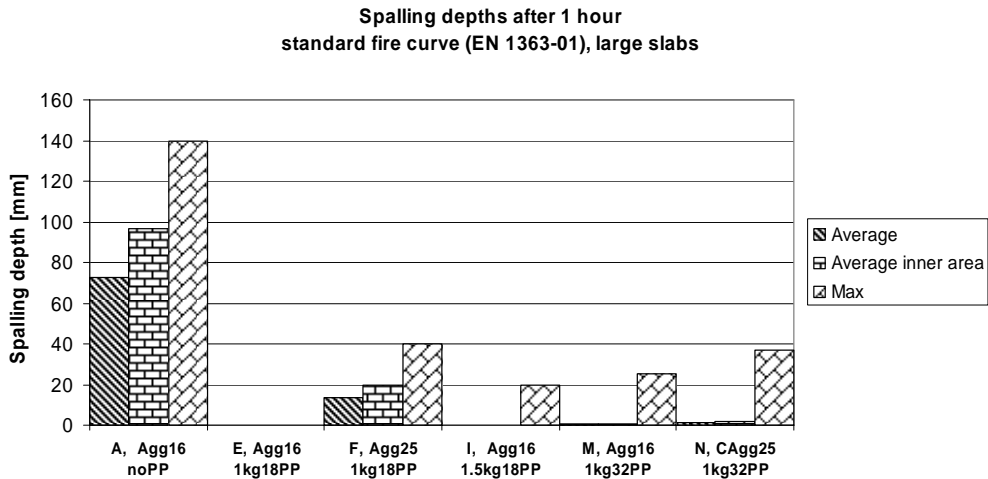

Figure 2 The spalling depths measured after standard fire exposure. (Agg16= 16 mm max aggregate size, Agg25= 25 mm max aggregate size).

The more severe spalling behaviour for concrete without PP-fibres experienced during standard fire exposure was also found for the RWS fire exposure, see Figure 3. However, during RWS exposure all the concrete tested spalled. During the RWS exposure the fire tests were terminated after 30 minutes due to safety reasons.

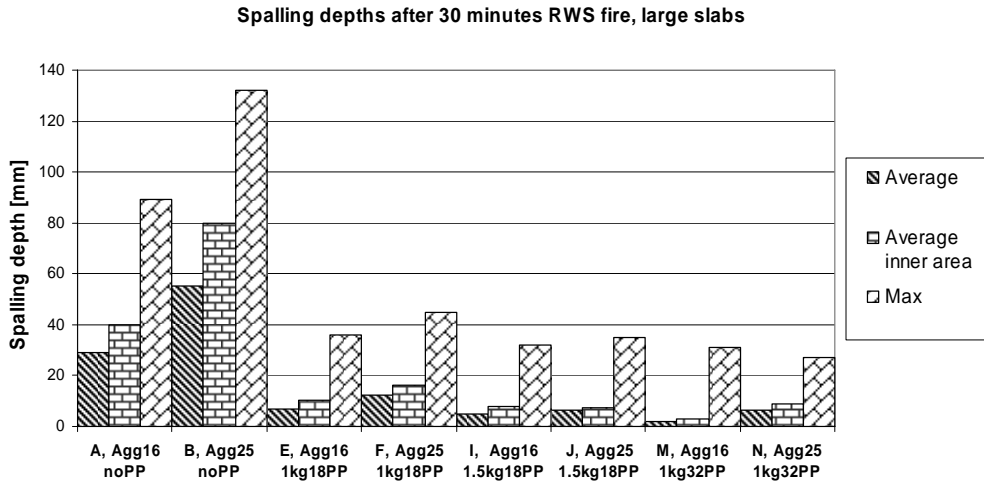

Figure 3 Spalling depths measured after RWS fire exposure. (Agg16= 16 mm max aggregate size, Agg25=25 mm max aggregate size).

The test program on small slabs consisted of 40 tests. As seen in Figure 4, the trends from the large tests are repeated in the small scale tests, i.e. all concrete without PP-fibres spalled (concrete A-D). There was also some spalling in one of the two specimens of concrete H. This concrete contained one kilogram of 18 μ m PP-fibres per cubic metre.

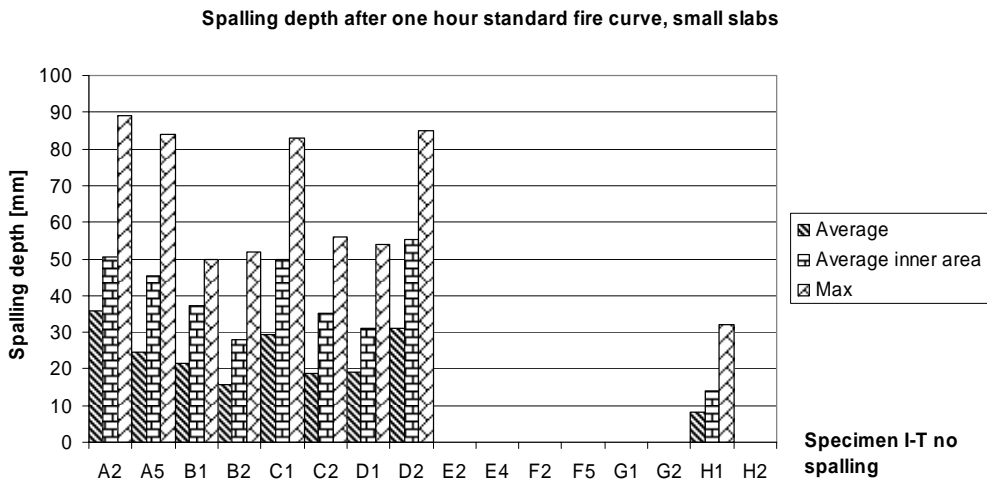

Figure 4 Spalling depths measured after standard fire exposure on small slabs tested on a small furnace.

If the results from these tests are compared with the results from the large scale test using standard fire exposure, it can be seen that the spalling is generally less severe on the small furnace. The reason for the difference is believed to be the much greater boundary effects on small specimens during the late stages of fire exposure. These boundary effects are probably negligible during the early stages of the exposure. Proof of this can be seen when comparing the times when spalling starts during the two tests using small slabs of concrete A and the single test using a large slab of concrete A. During the two small scale tests spalling starts after 7.75 minutes and 8.47 minutes which shall be compared with the spalling start 8 minutes during the test on the large slab. When the spalling then continues to a certain depth the boundary effects will be different for the large scale test relative to the small scale test. To summarise, small slabs can be used *both* to conduct an investigation of the risk for explosive spalling during one dimensional fire exposure, and to provide an indication of whether it is necessary to investigate the spalling depth in a larger slab to verify large scale performance. This is an important characteristic of the small scale test which increases the intrinsic predictive quality of the small scale results.

4. MATERIAL TESTS

To investigate the effect of PP-fibres, different types of additional testing were performed. During moulding of the concrete for the fire tests extra slabs were manufactured for material testing. Cores for material testing were drilled from the slabs when the concrete was less than one week old. The material testing specimens were kept in plastic bags until the time of testing.

4.1 Drying tests

To investigate the drying behaviour of concrete when exposed to heat, a series of tests were performed on cylinders. The main goal was to explore possible differences between concrete with and without the addition of PP-fibres. The most widespread theory concerning the action of PP-fibres is that they promote fast drying by melting and providing channels for the internal moisture to escape [3]. This theory is, however, not the only explanation that has been promulgated. Schneider and Horvath [4] highlight the following theories:

- Improvement of the permeability due to formation of capillary pores when the fibres melt and burn.
- Improvement of the permeability caused by the development of diffusion open transition zones near the fibres.
- Improvement of the permeability due to additional micro pores, which develop during the addition and mixing of fibres in the concrete mix.
- Improvement of the permeability due to additional micro cracks at the tip of the PP-fibres which develops during heating up and melting

One should note, however, that all the above theories indicate that in some way the drying process, i.e. moisture transfer, is somehow facilitated by the presence of PP-fibres.

Cylinders, with diameters 34 or 60 mm and length 300 mm, were exposed to three different heating ramps, i.e., 1, 2 or 5 degrees per minute. The heating was performed in a cylindrical

furnace with a height of 400 mm and diameter of 200 mm. During the heating, the specimens were hanging on a wire connected to a weight measurement device. The temperature, regulated by the system and shown in the diagrams, was measured a couple of mm from the vertical centre of the specimen.

An example of results from the drying tests on 34 mm cores heated with a 2 degree per minute ramp can be seen in Figure 5 and Figure 6. Concrete A, B and U (reference) are the ones without addition of PP-fibres. When analysing the diagram in Figure 5 it can be seen that U, the reference concrete, exhibits the fastest total weight loss rate up to approximately 400 °C. The weight loss behaviour of concrete A is somewhere in the middle of that shown by all tested concretes while concrete B has the lowest total weight loss after approximately 230 °C. The derivative of the weight ratio curve is shown in Figure 6. With this type of presentation it is easier to discern a systematic difference between the concrete with and without PP-fibres. Concrete A and B have the lowest maximum weight loss rate and the peak in weight loss rate comes at a higher temperature for the concrete with PP-fibres. The reference concrete, U, shows a different type of behaviour, i.e., it exhibits an early peak with a high weight loss rate.

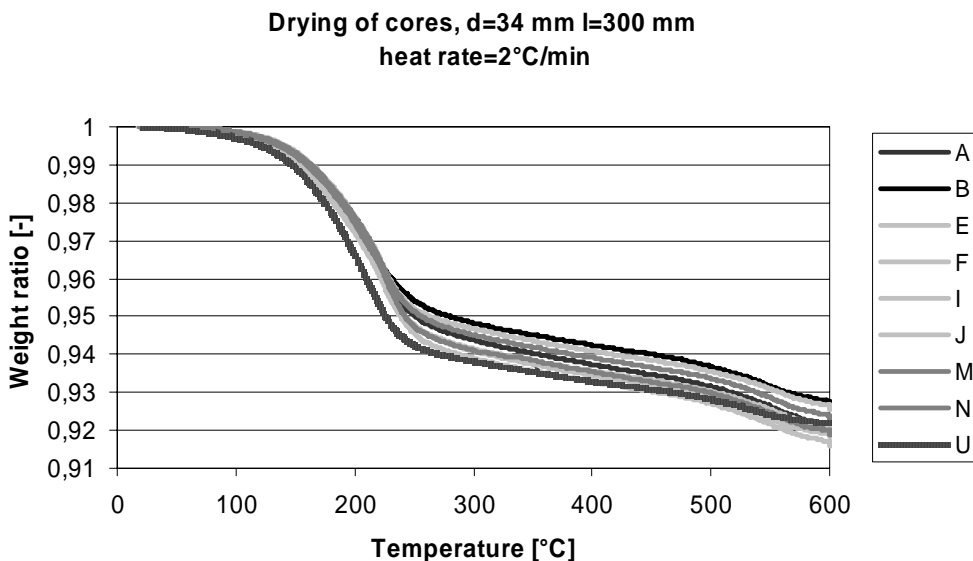

Figure 5 The weight loss of 34 mm cores at the heating rate of 2 °C/minute. Different colours have been used to indicate the different formulations as defined in table 1. The figure illustrates the fact that the weight loss performance of the cores follows the same general trend for all formulations.

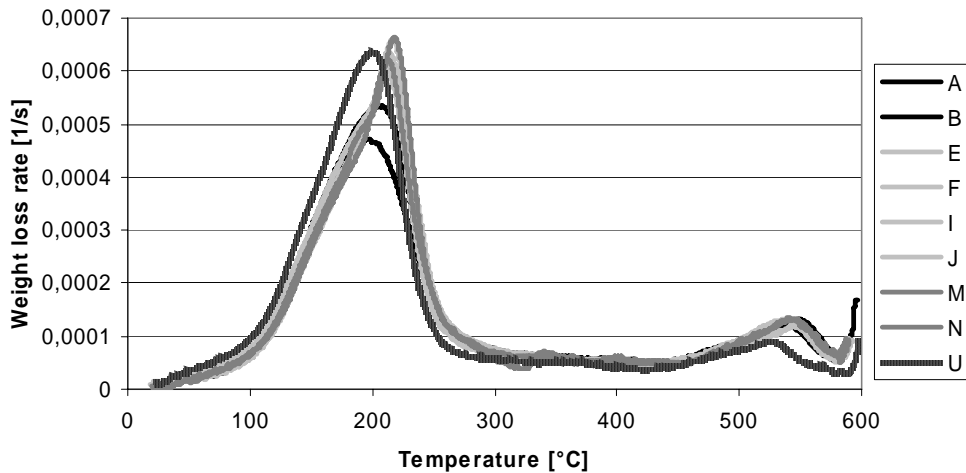

Figure 6 Weight loss rate of 34 mm cores at the heating rate 2 °C/minute. Different colours have been used to indicate the different formulations as defined in table 1. The figure illustrates systematic differences between the rate of weight loss for the different formulations, e.g A and B have a lower first peak; E, F, I, J, M and N have a slightly delayed (high) first peak; and U exhibits an early, high first peak.

4.2 Speed of sound

Some clear trends can be discerned when comparing concrete with and without the addition of PP-fibres with respect to the speed of sound, or more precisely the change in speed of sound as a result of heating. Although the heating rates used in these experiments are low, 1, 2 and 5 °C per minute, compared with the rapid heat exposure that leads to fire spalling during a fully developed fire, it is interesting to see how different heating rates influence the change in speed of sound in these specimens. The main trend is that during the most rapid heating used in these tests, 5 °C per minute, specimens without PP-fibres exhibits the greatest damage, see as an example Figure 7. When the heating rate is lower, 1 and 2 °C per minute, this is not as clearly evident.

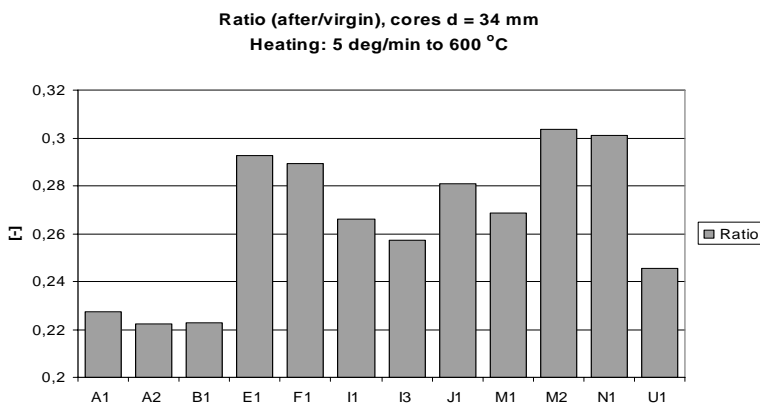

Figure 7 Speed of sound ratio (after/virgin), cores d =34 mm, heating: 5 °/min up to 600 °C

4.3 Permeability after different heating scenarios

The influence of the heating rate on the residual permeability was investigated with the Cembureau method with nitrogen as gas. Two heating scenarios were investigated: 1 °C per minute, or heat shock in a pre-heated furnace, to two target temperatures: 400 °C and 600 °C. The heating at 1 °C per minute was performed in the same furnace that the drying tests were performed in.

The results from this type of permeability experiment after rapid heat exposure shall not be seen as material data, because there will not be a uniform crack pattern through the whole specimen. Furthermore, the results from residual tests do not necessary reflect the behaviour at high temperature. The results are, however, an indication that different heating scenarios can influence the mechanical properties in different ways. The results from the experiments with different heating rates can be seen in Table 4 and Table 5. When heating to 400 °C the investigated heating rates do not influence the residual permeability, i.e. the ratio of the permeability from the specimen heated with thermal shock and by the heating rate of 1 °C per minute do not vary significantly when comparing before heating and after heating. When the same experiment is repeated using the oven pre-heated to 600 °C, however, the specimen exposed to thermal shock is more cracked than the specimen heated slowly. The specimen exposed to a thermal shock has twice the residual permeability as the specimen that has been heated slowly. Cracks close to the edges could be seen on the specimen exposed to thermal shock.

Table 4 Permeability after different heating rates to 400 °C.

	<i>Permeability before heating</i>	<i>Heating</i>	<i>Permeability after heating to 400 °C</i>
A4	2E-17	Thermal shock 400 °C	3,7E-15
A5	2E-17	1 deg/min	3,5E-15
ratio:	1,1		1,1

Table 5 Permeability after different heating rates to 600 °C.

	<i>Permeability before heating</i>	<i>Heating</i>	<i>Permeability after heating to 600 °C</i>
A8	3,2E-17	Thermal shock	8,13E-14
A6	3,2E-17	1 deg/min	3,84E-14
ratio:	1,0		2,1

4.4 Free thermal strain

Tests of the free thermal expansion of concrete types A, E and I were performed in a test apparatus located [5] at Centre Scientifique et Technique du Bâtiment (CSTB) in France. The thermal expansion up to 600 °C was measured on cores with a diameter of 104 mm and length of 300 mm. The used heating rate was 1 degree per minute.

Test results from the thermal expansion measurements performed on concrete types A, E and I show, as seen in Figure 8, quite similar result for the different concretes. This is expected because the only difference between the concretes is the amount of PP-fibres added and the major driving force for expansion is the aggregate which is the same in all mixes. There is one interesting difference although it is small. As seen in figure 9, at around 200-250 °C the thermal expansion decreases to zero or close to zero for concretes E and I. After this decrease there is an increased expansion rate between 250-300 °C compared to concrete A, so at 300 °C the total strain is almost the same as before the strain plateau. Concrete A is free from PP-fibres while concrete E contains 1 kg/m³ 18 µm PP-fibres and I contains 1.5 kg/m³ 18 µm PP-fibres. Further, the decrease is highest for the highest content of PP-fibres. This behaviour can be seen both in the longitudinal and radial direction of the tested cylinders.

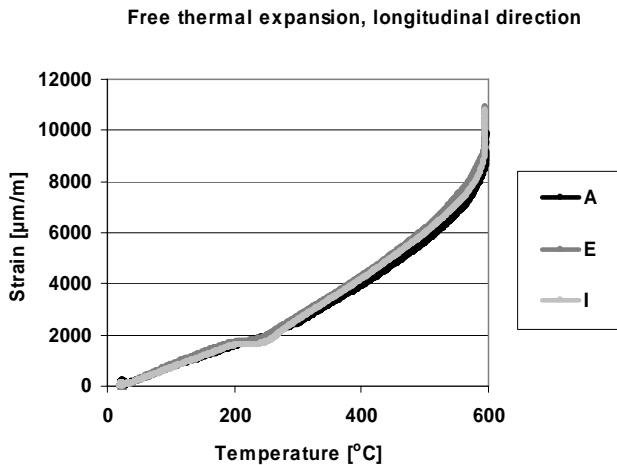

Figure 8 Free thermal expansion conducted on specimens A, E and I between 0 and 600 °C.

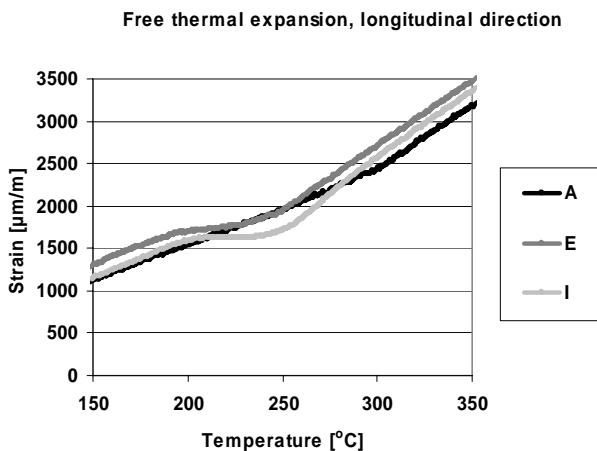

Figure 9 Free thermal expansion conducted on specimens A, E and I between 150 and 350 °C.

5. CONCLUSIONS

The addition of polypropylene fibres in concrete prevents or reduces the amount of fire spalling. In this experimental program no systematic effect could be seen on the amount of spalling as a function of the size or quantity of PP-fibres. During the RWS fire exposure all types of concrete spalled to some extent. This should be compared with the standard fire exposure where the concretes without PP-fibres and only the concrete with 1 kg 18 μm PP-fibres and 25 mm maximum aggregate size exhibited spalling of the whole surface. The mechanism, or mechanisms, leading to this reduction of spalling by PP-fibres is not known in detail. However, the effects of a PP-fibre addition were shown in several different areas in the present research project. PP-fibres:

- reduce or prevent fire spalling
- modify the capillary saturation close to the surface of concrete
- limit the internal destruction at moderate heating, 5 °C per minute.
- modify the drying behaviour at high temperature
- introduce a plateau in the free thermal strain curve.

Other findings, from a limited study of material properties, concluded that concrete without PP-fibres heated with a thermal shock to 600 °C had twice the residual permeability as concrete heated at a heating rate of 1 °C per minute to the same target temperature. The same test performed with a target temperature of 400 °C did not reveal any measurable difference.

6. ACKNOWLEDGEMENTS

This project was supported by the Swedish Road Administration (registration number: AL 90B 2005:16378) which is gratefully acknowledged. The work was expanded in the material sciences field with support from the Swedish Research Council, FORMAS, (registration number: 243-204-1992).

7. REFERENCES

- [1] Jansson R., Boström L. *Spalling of concrete exposed to fire*, SP Report (to be published)
- [2] Hedenblad G. & Nilsson L. -O. (1985) *Degree of Capillary Saturation –A tool for accurate determination of the moisture content in concrete* Report TVBM-3022 (in Swedish), Lund, 1985, 69 pp.
- [3] Khoury (2000). Effect of fire on concrete and concrete structures *Prog. Struct. Engng Mater.* 2000; 2
- [4] Schneider & Horvath (2003). *Behaviour of ordinary concrete at high temperature* Technische Universität Wien, Heft 9, 2003
- [5] Hager I. - *Propriétés Mécaniques des Bétons à Haute Performance à Haute Température – Évolution des Principales Propriétés Mécaniques*, Thèse de Doctorat, Ecole Nationale des Ponts et Chaussées, Paris, 2004, 172 pp.

