



# LUND UNIVERSITY

## Effect of chemical combination on x-ray emission spectrum

Johnson, Nils G.

1939

[Link to publication](#)

*Citation for published version (APA):*

Johnson, N. G. (1939). *Effect of chemical combination on x-ray emission spectrum*. [Doctoral Thesis (monograph), Department of Physics]. Lindstedts Universitetsbokhandel.

*Total number of authors:*

1

### General rights

Unless other specific re-use rights are stated the following general rights apply:

Copyright and moral rights for the publications made accessible in the public portal are retained by the authors and/or other copyright owners and it is a condition of accessing publications that users recognise and abide by the legal requirements associated with these rights.

- Users may download and print one copy of any publication from the public portal for the purpose of private study or research.
- You may not further distribute the material or use it for any profit-making activity or commercial gain
- You may freely distribute the URL identifying the publication in the public portal

Read more about Creative commons licenses: <https://creativecommons.org/licenses/>

### Take down policy

If you believe that this document breaches copyright please contact us providing details, and we will remove access to the work immediately and investigate your claim.

LUND UNIVERSITY

PO Box 117  
221 00 Lund  
+46 46-222 00 00



*Fil. mag. Kurt Lidén  
från Vännen förp.*  
**NILS G. JOHNSON**

*A:26*

# **EFFECT OF CHEMICAL COMBINATION ON X-RAY EMISSION SPECTRUM**

AN EXPERIMENTAL STUDY OF THE  $K\alpha_{1,2}$ -DOUBLET  
OF THE ELEMENTS 11 Na—16 S



A.-B. PH. LINDSTEDTS UNIV.-BOKHANDEL, LUND

**EFFECT OF CHEMICAL COMBINATION  
ON X-RAY EMISSION SPECTRUM**

**AN EXPERIMENTAL STUDY OF THE  $K\alpha_{1,2}$ -DOUBLET  
OF THE ELEMENTS 11 Na-16 S**

BY DUE PERMISSION OF THE PHILOSOPHICAL FACULTY OF THE UNIVERSITY  
OF LUND TO BE PUBLICLY DISCUSSED IN THE LECTURE HALL OF THE  
PHYSICAL INSTITUTE, MAY 20<sup>th</sup> 1939, AT 10 O'CLOCK, FOR THE  
DEGREE OF DOCTOR OF PHILOSOPHY

BY

**NILS G. JOHNSON**

PHIL. LIC., HBG

L U N D  
PRINTED BY HÅKAN OHLSSON  
1 9 3 9

EFFECT OF CHEMICAL COMBINATION  
ON X-RAY EMISSION SPECTRUM

AN EXPERIMENTAL STUDY OF THE  $K\alpha_{1,2}$ -DOUBLET  
OF THE ELEMENTS 11 Na-16 S

BY

NILS G. JOHNSON

LUND  
PRINTED BY HÅKAN OHLSSON  
1939

*TO MY PARENTS*

## PREFACE.

This paper treats of measurements of the  $K\alpha_{1,2}$ -doublet of some lighter elements, 11 Na—16 S, in various compounds. The work is a continuation of earlier investigations into the effect of chemical combination on K series emission spectra carried out at the Physical Institute of the University of Lund.

I beg to express my gratitude to my chief, Prof. JOHN KOCH, for the modern technical equipment he kindly placed at my disposal, for his interest in my work, and for all the advice I received from him in the course of the work.

I am much indebted to Fil. D:r OSVALD LUNDQUIST for kindly introducing me into the technics of x-ray research and for his most valuable help.

I wish to thank Fil. Mag. K. F. LANDÉN, who with great skill prepared a number of compounds for the investigation.

My thanks are also due to the chief mechanician of the Institute, Mr A. L. PEDERSEN, and to his assistant, Mr G. AUGRELL, who with their usual ability carried out various technical tasks.

For financial assistance I thank the »Kungl. Fysiografiska Sällskapet i Lund».

Lund, April 1939.

*Nils G. Johnson.*

## CONTENTS.

	Page
Preface .....	5
Ch. 1. Introduction .....	7
Ch. 2. Experimental Arrangements .....	14
1. The Spectrographs .....	14
2. The Tube .....	17
3. The Substances .....	21
Ch. 3. Measurements .....	24
1. Photographing the Spectra .....	24
2. The Wave-lengths .....	28
3. The Widths of the Lines .....	36
4. The Shifts .....	39
5. The Accuracy of the Measurements .....	40
Ch. 4. X-Rays and Interaction between Atoms .....	42
1. Chemical Combination and Crystal Types .....	42
2. The Appearing of Chemical Effects on X-ray Spectra ....	44
3. Theoretical .....	46
Ch. 5. Discussion of the Shifts .....	51
1. General Survey .....	51
2. The Shifts for Cations as Function of the Atomic Number of Disturbing Anions .....	55
3. The Shifts as Function of the Atomic Number of the Emitting Cations .....	60
4. Oxygen Compounds .....	66
5. Sulphides, Phosphides and Silicides .....	70
Summary .....	71

## CHAPTER 1.

### Introduction.

*Historical.* In 1924 an effect of chemical combination on x-ray line spectra — the effect on absorption spectra had already been found — was discovered by A. E. Lindh and O. Lundquist<sup>1</sup> on the  $K\beta$ -lines of the elements sulphur, phosphorus and chlorine, these workers being able to show that different positions and relative intensities of the  $K\beta_1$ , and  $K\beta_x$  result according to the exposed compound and the underlying target material. In 1925 E. Bäcklin<sup>2</sup> and B. B. Ray<sup>3</sup> submitted the important proof that the effect is not only limited to the outer levels, containing the external or valency electrons, but is extended to the L-shell. Ray clearly showed that in sulphites and sulphates there are small but distinct shifts of the  $K\alpha_{1,2}$ -doublet towards shorter wave-lengths in relation to the doublet of the pure element. Bäcklin, too, found shifts of the sulphate doublet, amounting to 1.3 volts or about the same as the doublet distance, and he also detected similar shifts of the doublets of oxygen compounds of aluminium, silicon and phosphorus, the shifts going towards shorter wave-lengths and being in volts 0.31 for  $Al_2O_3$ , 0.57 for  $SiO_2$ , and 0.89 for  $P_2O_5$ .

Later investigations of the  $K\alpha_{1,2}$ -doublet in compounds — measurements of  $K\beta$ -lines and  $K\alpha$ -satellites lie outside this subject — aimed in the first place at studying the sulphur doublet, which is well-defined and accessible for observation in many compounds. A. Faessler<sup>4</sup> and O. Lundquist<sup>5</sup> introduced the method of secondary

<sup>1</sup> Ark. f. Mat., Astr. and Fysik 18, Nos 14, 34 and 35, 1924.

<sup>2</sup> ZS f. Phys. 33, 547, 1925; 38, 215, 1926.

<sup>3</sup> Phil. Mag. (6) 49, 168, 1925; 50, 505, 1925.

<sup>4</sup> ZS f. Phys. 72, 734, 1931.

<sup>5</sup> Diss. Lund 1931; ZS f. Phys. 77, 778, 1932.

fluorescent x-rays for the purpose of studying chemical effects on the  $K\alpha_{1,2}$ -doublet. Faessler was the first to show that the shift of the doublet towards longer wave-lengths in sulphides is dependent on the metal ion, as for instance the S  $K\alpha_{1,2}$  proves to have greater wave-lengths for CaS than for ZnS. Using his specially constructed tube, Lundquist alone was able to investigate with success sulphites, which easily decompose in vacuum. He showed that the effect for the lower valency of S in sulphites is evidently smaller than for the maximum valency in sulphates. Later on, Lundquist<sup>6</sup> proceeded with his measurements on sulphides and also studied the phosphorus and the chlorine doublet when the emitting atom P or

TABLE 1.

$K\alpha_{1,2}$	Emitting element	Compound	Shift Volts
15 P		Hypophosphite	-0.52
		Phosphite	0.71
		Phosphate	0.81
16 S		Sulphite	0.90
		Sulphate	1.18
17 Cl		Chlorate	1.21
		Perchlorate	1.62

Cl is bound to oxygen in different states of valency. As a rule he found that the effect increases with the valency, being greatest when all valency electrons are engaged in chemical combination. Lundquist's results for oxygen compounds are brought together in Table 1; the P  $K\alpha_{1,2}$ -shift is referred to red phosphorus, the S  $K\alpha_{1,2}$ -shift to pure sulphur, the Cl  $K\alpha_{1,2}$ -shift to chlorides. As to sulphates, Faessler's and Lundquist's measurements agree well, whereas in sulphides Faessler found greater effects than Lundquist.

J. Valasek,<sup>7</sup> who has more especially devoted his attention to effects on  $K\beta$ -lines, has also investigated the  $K\alpha_{1,2}$ -doublet in some sulphides, using the specially constructed target that is described below.

<sup>6</sup> ZS f. Phys. 83, 85, 1933; 89, 273, 1934; 102, 768, 1936.

<sup>7</sup> Phys. Rev. (2) 43, 612, 1933.

With a h  
crystal gratin  
obtained thro  
of aluminum  
that the  $\alpha$ -gr  
lengths in re  
ment H. K:  
Si  $K\alpha_{1,2}$ -doubl  
pounds silico

V. Kunzl  
method, and  
magnesium  
An attempt  
the spectra,  
tube with dif  
as no shift c

The S  $K\alpha_{1,2}$   
by L. G. P  
Exciting dir  
ionization cu  
support in th

*The meth*  
is placed on  
several distu  
character co  
the temperat  
pass away, a  
material. Be  
which by ej  
between ato  
confirmed by  
the doublet  
spectrograms

<sup>8</sup> ZS f. Ph

<sup>9</sup> ZS f. Ph

<sup>10</sup> ZS f. Ph

<sup>11</sup> Phys. R

With a high-vacuum spectrograph provided with a concave crystal grating (principle Johann), H. Karlsson and M. Siegbahn<sup>8</sup> obtained through electron impact excitation the K emission spectra of aluminum and magnesium and of their oxides. They report that the  $\alpha$ -groups of the oxides are shifted towards shorter wave-lengths in relation to those of the metals. With a similar arrangement H. K:son Flemberg<sup>9</sup> measured the wave-lengths of the Si  $K\alpha_{1,2}$ -doublet for crystalline silicon and for the stable compounds silicon oxide and silicon carbide.

V. Kunzl<sup>10</sup> used a low tension gas tube and a simple focussing method, and photographed the K emission spectra of sodium, magnesium and aluminium with special regard to weak lines. An attempt to measure the influence of chemical combination on the spectra, carried out specially for magnesium by filling the tube with different gases ( $N_2$ ,  $H_2$ ,  $O_2$ ), did not meet with success, as no shift could be established.

The S  $K\alpha_{1,2}$ -doublet was also the object of an investigation by L. G. Parrat,<sup>11</sup> who applied a non-photographic method. Exciting directly several sulphides and sulphates, he recorded ionization curves with the two-crystal spectrometer. His results support in the main earlier measurements.

*The method of secondary fluorescent x-rays.* When a compound is placed on a target and exposed in vacuum to electron impact, several disturbing effects of chemical, thermal and electrical character concur to decompose and change it. In the focal spot the temperature grows very high, many compounds evaporate and pass away, and the rest often dissociate or react with the target material. Besides this, there may be a direct effect of the  $\beta$ -rays, which by ejecting the valency electrons break down the bonds between atoms. It was also an early experience of Bäcklin's, confirmed by Lundquist, that by exposing for example sulphates the doublet due to the pure element S will also appear on the spectrograms. Demonstrations showing that chemical reactions

<sup>8</sup> ZS f. Phys. 88, 76, 1934.

<sup>9</sup> ZS f. Phys. 96, 167, 1935.

<sup>10</sup> ZS f. Phys. 99, 481, 1936.

<sup>11</sup> Phys. Rev. (2) 49, 14, 1936.

actually take place on the target are given by R. Glocker and H. Schreiber<sup>12</sup> as well as by Lundquist.<sup>13</sup> By using several different targets the latter was able to show for many sulphur compounds that the line-structure is highly modified according to the material of the target underlying the substance.

Even if a compound is chemically permanent under the influence of temperature, a change in it appearing as a modified crystal structure and caused by high temperature may occur. Thus it is a laboratory experience that quartz, which at normal temperature is a crystal of diamond type and not electrically conducting, assumes at elevated temperature the properties of an ionic crystal and becomes conducting.

In order to overcome the discussed effects, Lindh and Lundquist<sup>14</sup> suggested the use of secondary fluorescent x-rays for exciting chemical compounds. Some tubes adapted to this purpose may be mentioned. The practical application of x-ray spectroscopy in chemical analysis gave rise to several tubes for fluorescent rays, e. g. constructions by Stintzing, Coster and Hevesy. A tube devised by E. Alexander and A. Faessler<sup>15</sup> and intended for studying chemical effects on the  $SK\alpha_{1,2}$ -doublet conforms to an earlier construction by D. Coster and J. Druyvenstein<sup>16</sup> that was used with success for chemical analysis. In the tube by Alexander and Faessler the fluorescent ray plate is fixed at a short distance of about 4 mm from the target, the plate being mounted on the electron focussing shield of the filament and well water-cooled. Alexander and Faessler designed another tube, in which the fluorescent ray plate is placed outside the highvacuum at a distance from the target of 15 mm. This later tube, having a small intensity, is convenient only for harder x-rays.

The first tube used by Lundquist<sup>17</sup> agrees in the main with a tube suggested by Lindh. In this tube the specimen is placed on a four-faced radiator, so that a fresh sample can be put in

<sup>12</sup> Ann. d. Phys. 85, 1089, 1928. See further H. Schreiber, ZS f. Phys. 58, 619, 1929.

<sup>13</sup> L. c.

<sup>14</sup> L. c.

<sup>15</sup> ZS f. Phys. 68, 260, 1931.

<sup>16</sup> ZS f. Phys. 40, 765, 1926.

<sup>17</sup> L. c.

after an exposure reducing the m...  
Lundquist pr...  
measuring th...  
surface. At a...  
a heating of...  
Lundquist de...  
radiator from...  
in a later tub...

J. Valasek...  
method. The...  
on the target...  
stream by a...  
the front of...  
chemical reac...  
screens the s...  
focal spot.

When the...  
however, the...  
lower atomic...  
degree, the g...  
liberating sec...  
M. Haas,<sup>19</sup> th...

The series...  
fluorescence y...

The gains...  
involve not on...  
also an advan...  
the fluorescent...  
11 Na—17 Cl...  
are to some ex...

<sup>18</sup> L. c.

<sup>19</sup> Ann. d. P...

Glocker and  
using several  
many sulphur  
ied according  
nce.

nt under the  
as a modified  
y occur. Thus  
h at normal  
ot electrically  
properties of

dh and Lund-  
nt x-rays for  
o this purpose  
x-ray spectro-  
ral tubes for  
g, Coster and  
Faessler<sup>15</sup> and  
S  $K\alpha_{1,2}$ -doublet  
d J. Druyven-  
analysis. In the  
r plate is fixed  
the plate being  
filament and  
l another tube,  
he highvacuum  
r tube, having  
rays.

the main with  
imen is placed  
can be put in

iber, ZS f. Phys.

after an exposure of each surface lasting but a few hours, hence reducing the risk of the specimen being changed by the radiation. Lundquist proved that the substance is safe from heat by measuring thermo-electrically the temperature of the radiator surface. At a tension of 35 kV and a current of 30 mA he got a heating of only 6°. In order to shorten the exposure times Lundquist decreased the distance from the focal spot to the radiator from 22 mm in two older designs of his tube to 15 mm in a later tube.

J. Valasek<sup>18</sup> has used in many investigations a semi-secondary method. The substance, compressed to a small tablet, is placed on the target but protected from the direct impact of the electron stream by a copper shield, the focal spot being some mm from the front of the material. By this arrangement the chance of chemical reactions is greatly reduced. Another metal shield screens the spectrograph slit against direct radiation from the focal spot.

When the elements 11 Na—17 Cl are excited by x-rays, however, the yield turns out to be very small. These elements of lower atomic number emit fluorescent x-rays only in a small degree, the greater part of the received energy being used for liberating secondary electrons. According to measurements by M. Haas,<sup>19</sup> the fluorescence yields in the K series are:

12 Mg	1.3 %
14 Si	3.8
16 S	8.3
17 Cl	10.8

The series demonstrates also the rapid decrease of the fluorescence yield with the atomic number.

The gains of the tubes for secondary fluorescent x-rays involve not only a reduced risk of changes of the compound but also an advantageous suppression of the continuous spectrum in the fluorescent radiation, although when investigating the elements 11 Na—17 Cl these gains, owing to the small fluorescence yields, are to some extent balanced by the disadvantage of small intensity

<sup>18</sup> L. c.

<sup>19</sup> Ann. d. Phys. (5) 16, 473, 1933.

of the tubes, this decreasing with increasing distance between target and substance. The considerable distance of 15 mm used by Lundquist in his chlorine investigation (plane crystal grating) necessitated in order to get well exposed spectrograms up to 10 hours' exposure in spite of high intensity of the primary exciting x-rays. (35 kV, 30 mA.)

With the appearance of the concave crystal gratings in x-ray spectroscopy the small intensity of the tubes for secondary rays is no longer a problem, as these gratings give a considerably higher intensity than the plane gratings. It is even possible in some cases to excite compounds by direct electron impact: by using a large focal spot and carrying the tube with small load, the temperature of the substance placed on the target can be kept comparatively low and yet lines of good intensity can be got in a short time without risking a change of the compound, at any rate of stable compounds. For instance, Flemberg<sup>20</sup> studied by direct excitation the  $\text{Si K}\alpha_{1,2}$ -doublet of crystalline silicon, silicon oxide and silicon carbide. However, the tube must be worked with very good high-vacuum, as a slight oxidation of the pure element is liable to take place when traces of oxygen remain in the tube.

Nevertheless, for most compounds of the elements 11 Na—17 Cl the method of exciting by fluorescent x-rays holds its superiority over the method of direct excitation.

The purpose of this investigation into effects of chemical combination on the  $\text{K}\alpha_{1,2}$ -doublet of the elements 11 Na—16 S was to obtain the wider experimental material demanded for drawing conclusions of general application. It was originally intended to confine the measurements<sup>21</sup> to the elements 11 Na—14 Si. In the course of the work it seemed reasonable to extend them to some compounds of phosphorus and sulphur which had so far not been studied.

<sup>20</sup> L. c.

<sup>21</sup> Preliminary reports: *ZS f. Phys.* 95, 93, 1935; 102, 428, 1936.  
*Nature* 138, 1056, 1936.  
*Phys. Rev.* (2) 53, 434, 1938.

The chief effects on the emitting 11 Na—16 S anions, each of the period the bivalent elements in the other elements 9 F, subject permanent character atom should valency, i. e. combination, combination built down to should also in this case argon structure

Preliminary O-bond is not the elements silicates, phosphates

While the ordinary properties compounds with in a state of

The  $\text{K}\alpha_{1,2}$  11 Na—17 Cl Lundquist determined perchlorates and show the same compounds to element 17 Cl knowledge of

The chief guiding principle of the investigation was to study effects on the  $K\alpha_{1,2}$ -doublet caused by the direct linkage of the emitting atom and another one. Thus the emitting atoms 11 Na—16 S were combined, as cations, in first place with, as anions, each of the four last elements in the first horizontal line of the periodic table, viz. the tetravalent 6 C, the trivalent 7 N, the bivalent 8 O and the monovalent 9 F, at second hand with elements in the same (second) horizontal line, at third hand with other elements placed in the same periodic columns as 8 O and 9 F, subject in every case to the compound being in a fairly permanent crystalline form. When acting as a cation the emitting atom should be mainly investigated in its state of maximum valency, i. e. when all valency electrons are engaged in chemical combination, or, according to simple conceptions of only ionic combination when the electronic configuration of the atom is built down to the 8 electron shell of neon. The emitting atoms should also be observed when entering compounds as anions; in this case their electronic configurations are built up to an argon structure, S being bivalent, P trivalent and Si tetravalent.

Preliminary measurements showed that the effect of the formal O-bond is not the same in all oxygen compounds. Systematically the elements 11 Na, 12 Mg and 13 Al were investigated in their silicates, phosphates, sulphates and perchlorates.

While the work was in progress some digressions from the ordinary program turned out to be desirable; for instance, some compounds were investigated in which the emitting element was in a state of valency lower than maximum.

The  $K\alpha_{1,2}$ -doublet of chlorine, the last element in the series 11 Na—17 Cl, has not yet been observed. As was mentioned, Lundquist determined the shifts of the doublet in chlorates and perchlorates in relation to the chlorides, which among themselves show the same effect. As we cannot refer the shifts for chlorine compounds to the pure element, we desist from treating the element 17 Cl, which gives no contribution to our empirical knowledge of the effects.

## CHAPTER 2.

### Experimental Arrangements.

#### 1. The Spectrographs.

As the elements to be studied give soft K radiation, which is easily absorbed, the spectrograph is made for high-vacuum, not so much because of the air absorption rightly to be neglected, but to render it possible to separate the tube from the spectrograph by a very thin foil, this being in that case not disturbed because of different pressures on its two sides. The spectrograph receptacle *R*, which is made of an aluminum alloy, is shown in Fig. 1. Internally it is 10 cm in height and to allow of the largest spectrograph of a length about 84 cm to fit in. The lid, strongly reinforced on account of its irregular shape, is attached to the receptacle by two hinges on the straight side of the receptacle, the rim of which is here enlarged. The vacuum-tight packing on which the lid rests consists of a rubber ring (not indicated in Fig. 1) placed in a flute of the rim of the receptacle.

In the spectrographs a concave crystal was employed as grating. The method was originated by H. Johann<sup>1</sup> and admits of obtaining x-ray spectra with bent crystals and without a slit. The technique of the method has mainly been developed in Siegbahn's laboratory. For a detailed description reference may be made to A. Sandström.<sup>2</sup>

Three spectrographs were built for crystals bent to 500, 750, and 1000 mm respectively. The largest of these did not find any use in these investigations. The spectrographs are to be turned round a centre below the crystal, rolling on the plane bottom of

---

<sup>1</sup> ZS f. Phys. 69, 185, 1931.

<sup>2</sup> Diss. Upsala 1935.

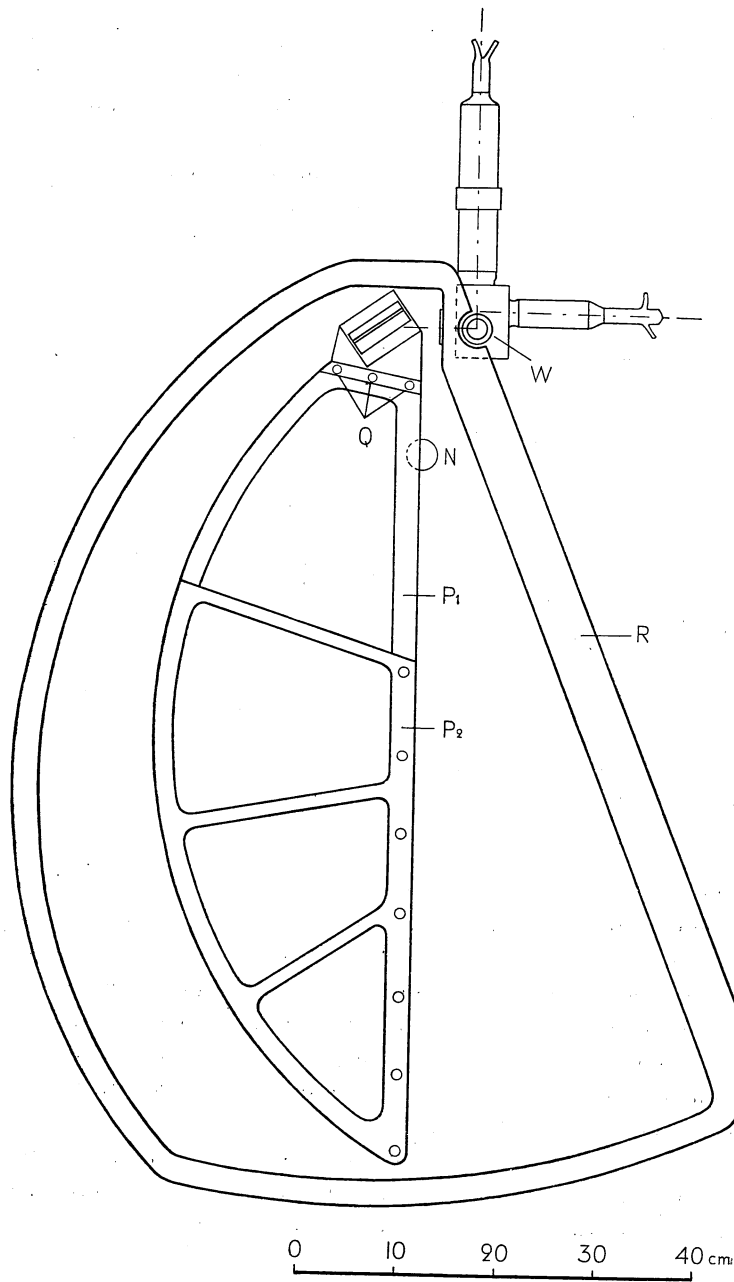

Fig. 1.

ts.

radiation, which is high-vacuum, not be neglected, but the spectrograph is disturbed because of the spectrograph receptacle shown in Fig. 1. The largest spectrograph is strongly reinforced by the rim of which the lid rests. 1) placed in a

was employed as Mann<sup>1</sup> and admits without a slit. When developed in reference may

to 500, 750, did not find any are to be turned plane bottom of



range of  $15^\circ$ — $60^\circ$   
 and  $P_2$  are fastened  
 smaller  $P_2$  placed  
 of 5 mm for the  
 e segments are to  
 phic film is pressed  
 and fixed by three

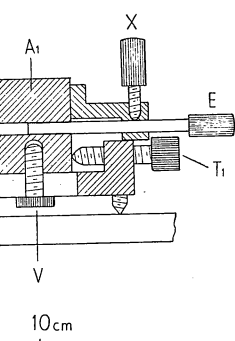

crystals to 750 and  
 ned by Sandström.<sup>3</sup>  
 d in his paper, in  
 onvenient procedure  
 onstruction of these  
 steel blocks,  $A_1$  and  
 and  $S_2$ . In the blocks  
 the crystal, allowing  
 of glancing-angles of  
 the crystal can be  
 ge  $E$  fastened by a

screw  $X$ . The crystal-holder pressed against the screws  $T_1$  and  $T_2$  by a spring  $Z$  can be moved on the crystal table by means of these screws on loosening the screw  $V$ . The height of the crystal table is varied by the screws  $U_1$ ,  $U_2$ , and  $U_3$ .

The third crystal-holder (500 mm) is an earlier type made in the Physical Institute of Upsala. This holder essentially agrees in design with the former ones, except that the crystal is bent by the pressure of only one screw.

The preliminary procedure of optically testing the crystal offers great advantages, as it makes the choice of a good crystal sample possible and at the same time facilitates the adjustment, by which the peripheries of the segments can be brought to coincide with the focussing-curve for the crystal sample. A luminous slit is placed on the Rowland-circle and the image obtained of it by reflexion on the surface of the bent crystal is observed for large glancing-angles. Crystals which give bad images are rejected. If the focussing-curve optically estimated for a good crystal does not differ too much from the Rowland-circle, the segment is moved — the reciprocal position of the crystal-table and the segment may be slightly changed at  $Q$  — until its periphery roughly coincides with the focussing-curve for the actual range of glancing-angles, this range generally not being very great in this investigation. The final adjustment is always performed by taking focal plates, moving the crystal-holder on the crystal-table until a good focussing is attained.

## 2. The Tube.

The tube for secondary fluorescent x-rays is in essentials a copy of the latest tube devised by Lundquist, though with small modifications in order to adapt the tube to the concave crystal grating. In his tube Lundquist has an arrangement for photographing the reference-lines by the method of direct excitation. This arrangement is not to be found in the tube devised by the author. Fig. 3 shows a section of the tube as well as a special design of the radiator. The target  $T$ , isolated with a porcelain-cylinder  $H$ , consists of a copper tube with a thin end-plate of

<sup>3</sup> ZS f. Phys. 88, 76, 1934.

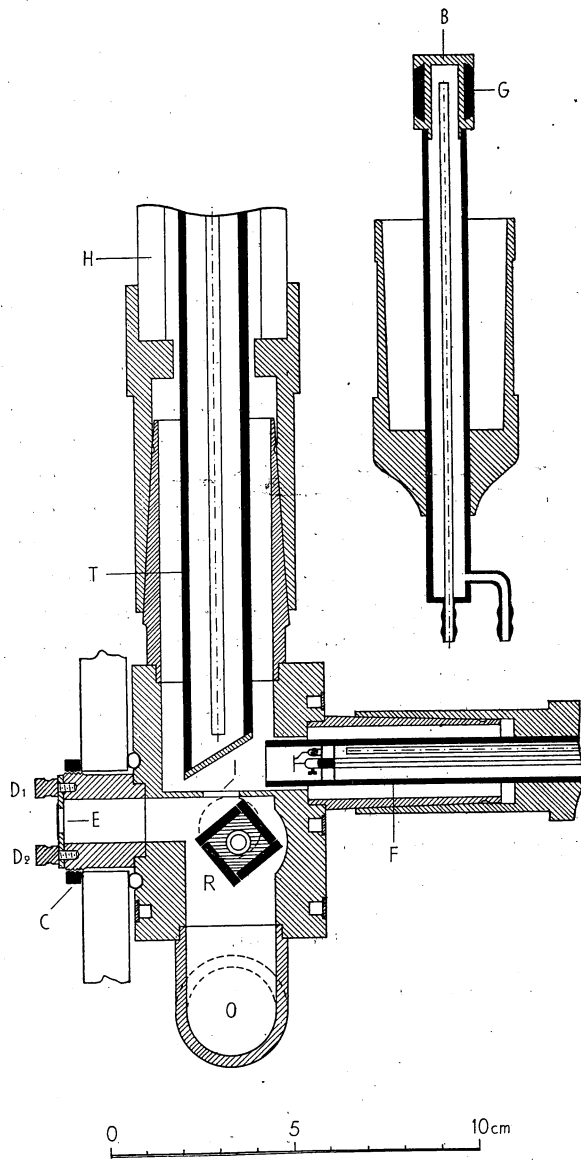

Fig. 3. The tube for secondary fluorescent x-rays.

copper, which is well water-cooled and in which the target material is wedged. This is to be so selected that its radiation at sufficient tension suffices to excite the substance strongly, that

is, the wave  
of the expo  
is advisable  
gives an im  
that has a  
lengths. Bu  
when the tu  
elevated ter  
and will set  
layer which  
reduce the  
Hence a silv  
is melted in  
results. Thr  
exciting the  
elements sho

Emit
1
1
1
1
1
1

The x-ra  
I in a diaph  
chamber of  
direct heat r  
distance of 1  
for two reas  
covered with  
the tungsten  
the other bei  
may not be a  
are wedged  
water-cooled

is, the wave-lengths which correspond to the K absorption edge of the exposed element must carry much energy. Sometimes it is advisable to employ a high-atomic metal such as tungsten that gives an intense continuous radiation, or a metal may be chosen that has a characteristic spectrum in the actual range of wave-lengths. But there is one fact to be taken into account, viz. that when the tube has a high load the target material owing to the elevated temperature will inevitably evaporate to some extent and will settle down on the substance and cover this with a thin layer which, when consisting of a highly absorbing metal, will reduce the intensity of the soft K radiation from the substance. Hence a silver target, which can be effectively cooled — the silver is melted into the target — has in many cases yielded good results. Three different targets have proved to be convenient for exciting the atoms 11 Na—16 S. Their use in the case of the six elements should be clear from Table 2.

TABLE 2.

Emitting atom	Target material	Radiator material
11 Na	Silver	Silver and copper
12 Mg	Tungsten	Silver and copper
13 Al	Silver	Silver and copper
14 Si	Silver	Aluminium
15 P	Tungsten	Aluminium
16 S	Molybdenum	Aluminium and copper

The x-ray beam from the target passes through the opening *I* in a diaphragm and strikes the radiator, which is placed in a chamber of its own and is protected by the diaphragm against direct heat radiation from the filament *F*. A rather large average distance of 17 mm between the target and the radiator is preferred for two reasons, one being that the risk of getting the substance covered with a thin layer of the target metal or of tungsten from the tungsten-spiral of the filament is reduced with this distance, the other being that too strong an excitation of many compounds may not be advantageous. The plates *G* for fastening the samples are wedged in the four-faced copper block *B* (Fig 3), which is water-cooled. The side of the radiator-square measures 12 mm

-G

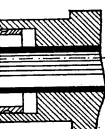

0cm

nt x-rays.

which the target  
and that its radiation  
distance strongly, that

proportionated to correspond to the wide split which is desirable for the concave grating. The split  $E$  is 3 mm high and 6 mm long, and by means of the screws  $D_1$  and  $D_2$  the split-plate closes the tube inside the vacuum-receptacle. Trials showed that an angle of about  $30^\circ$  between the side surface of the radiator and the direction from this to the grating is suitable. The little window  $W$  (Fig. 1) provides for inspection of the radiator. The split was in all experiments covered only with an aluminium-foil  $0.5 \mu$  thick in order to shut out the light in the tube from the spectrograph.

Certain properties are demanded for the material of the radiator plates  $G$ : it ought to be metallic in order to ensure a good cooling of the substance and the metal should be soft so that it can be rasped for the fastening of the specimens. Table 2 gives data concerning the metals used for this purpose. Aluminium is out of question for alkaline compounds — for instance, soda cannot be rubbed on aluminium. For such substances silver has been employed, or in some cases — mainly for sulphides — copper.

The connection of the tube with the spectrograph is clear from Figs. 1 and 3. The tube is pressed vacuum-tight (rubber-packings) to the receptacle by turning the ring  $C$ . The distance between the radiator and the grating amounts to about 9 cm.

As a matter of routine the tube was at times removed and carefully cleaned with nitric acid.

The evacuation is performed by two molecular pumps connected through tombac-tubes, one at  $O$  (Fig. 3) with the tube, the other at  $N$  (Fig. 1) with the spectrograph. The two tombac-tubes are joined to each other through a valve. When evacuation starts the valve is open, rendering the pressure equal on both sides of the aluminium-foil. At commencing high-vacuum the valve is closed, and so one pump works at the tube, the other at the spectrograph. This arrangement prevents destruction of the foil and improves the work of the tube, the small gas bubbles which are generated from the substance, and which would otherwise disturb the vacuum, being immediately swallowed by the pump working at the small tube volume.

The high-voltage unit is the same as the one used by Lundquist,<sup>5</sup>

<sup>5</sup> Diss. Lund 1931.

who gives  
and 150  
and 30  
construct

Many  
could be  
remained  
the purp  
so produ  
the emit  
is avoide  
present a  
ought to  
tively co  
Mg<sub>3</sub>B<sub>2</sub> is  
taken in

Since  
generally  
no specia  
powdere  
it often p  
this redu  
advisable  
foil sized  
with wat  
the faste  
tion (sol  
the comp  
some sili  
leaves to

The e  
dure. Th  
surface o

<sup>6</sup> Arch

<sup>7</sup> On

Müller, ZS

who gives a detailed description of it. It supplies up to 100 kV and 150 mA, but was not worked with a load exceeding 33 kV and 30 mA. The high voltage was measured by a voltmeter constructed by Starke and Schroeder.<sup>6</sup>

### 3. The Substances.

Many of the compounds investigated are trade products and could be bought with guaranties as to sufficient purity. There remained, however, a great many substances to be produced for the purpose of this research-work. To some degree these can be so produced that a disturbing impurity, i. e. a compound containing the emitting atom in another combination than the desired one, is avoided. Other impurities in which the emitting element is not present are only inconvenient for reasons of intensity. The work ought to be carried out so that the emitting element is quantitatively contained in the desired compound. For example, when  $Mg_3B_2$  is being produced by ignition of Mg and B, B should be taken in excess so that no metallic Mg remains.

Since the soft K radiation is easily absorbed, recourse must generally be had to rubbing the substance on the radiator plates, no special medium being used for fastening it.<sup>7</sup> However, for light powdered compounds ( $AlB_{12}$ ) which are attracted to the target it often proved preferable to fix the substance in collodion, though this reduced the thermal contact with the radiator. A more advisable method was to cover the substance with an aluminium-foil sized to the edges of the radiator. Compounds not reacting with water ( $Al_2O_3$ ) could be mixed with water, which facilitates the fastening, or they could be put on the radiator even in solution (soluble Na compounds). Of course, it was advantageous if the compound was procured in largish pieces. Thus, for instance, some silicates such as muscovite and orthoclase were fastened in leaves to the radiator.

The exposure of metallic sodium necessitated a special procedure. The metal was rubbed on the fluorescent plates below the surface of a fairly volatile fraction of mineral oil and covered

<sup>6</sup> Arch. f. Elektrotechnik 20, 115, 1928.

<sup>7</sup> On the preparation of substances in x-ray spectroscopy see E. A. W. Müller, ZS f. wiss. Photogr. 34, 181, 1935.

with a  $0.5 \mu$  thick aluminium-foil. Then the radiator was rapidly put into the tube and evacuation immediately started. The evaporating oil impeded the action of oxygen on the sodium, and also broke the foil so that the metal was free for exposure.

The white phosphorus was treated in a similar manner, except that the fastening in this case was performed in paraffin-oil.

For many substances that are hygroscopic (oxygen compounds of Mg) or that react with the moisture of the air (carbides and phosphides of Na and Mg) the fastening had to take place in an exsiccator. The substance, the preparing-knife and the radiator (with its water-channels closed) were kept in an exsiccator with phosphorus pentoxide for some hours. The rubbing performed with the knife was done in the exsiccator, after which the radiator was rapidly put into the tube and the latter immediately evacuated, the tube previously being carefully dried with phosphorus pentoxide. During its short passage between the exsiccator and the tube, the sample, though in some cases ( $Mg_3P_2$ ) covered with a thin aluminium-foil, comes into contact with some atmospheric moisture, this however being negligible in quantity.

No attempt whatever was made to photograph compounds affected by air ( $MgI_2$ ). Nor were substances decomposing in vacuum the object of any investigation. Other reasons excluded some compounds from observation; for instance,  $PCl_5$ , which, though covered with aluminium-foil, sublimated rapidly in vacuum before a minimum exposure was completed.

We may now turn to the question of the permanence of the compounds during the actual exposure. As already stated by Lundquist (p. 11) the effect of heat on the specimen is inconsiderable for this type of tube. A possible slight elevation of the radiator temperature is mainly due to heat radiation from the focal spot, and not to any measurable extent a consequence of transformation of x-ray energy into heat. There remains to be discussed the chemical action of x-rays, or the mechanism behind the absorption of x-rays by atoms in molecules. The primary x-rays eject photo-electrons from the atom, thus ionizing the atom. When the atom regains its normal state, because electrons in the outer levels fall into the vacancies created by the photo-electrons, the fluorescent characteristic radiation originates. The high speed photo-electrons or  $\beta$ -rays in their turn cause secondary effects,

liberating  
between i  
this I will  
that x-ray  
innumerab  
the exampl  
few in nu  
reduction  
are almost  
empiricall  
tional cas  
bonds in a  
radiation  
the irradi

As the  
procedure  
when exp  
change in  
establish  
its colour  
spectrogra  
permanen  
phorus g  
longest w  
oxidation  
tioned pr  
which wa  
 $Al_2S_3$  ind  
water, an

Genera  
impurity  
the result

\* Appli

liberating electrons in atoms too. The stability of chemical bonds between ionized atoms may be called in question. In regard to this I will cite G. Clark<sup>8</sup>: »The causal observer could well believe that x-rays by virtue of their penetration and energy should have innumerable profound chemical effects, but as a matter of fact the examples of considerable chemical change are extraordinarily few in number ... The photographic effect, a few oxidation-reduction reactions, and some condensations of organic compounds are almost unique among the larger number of experiments already empirically tried». Rightly we can assume that only in exceptional cases are the primary x-rays able to demolish the chemical bonds in a crystal, all the more so as the intensity of the primary radiation is small in our tube and the distance from its source to the irradiated substance rather large.

As the substance is under observation throughout the whole procedure — in the exsiccator when being prepared, in the tube when exposed, and further directly after the exposure — any change in it indicative of a possible decomposing is often easy to establish from the appearance of the compound, especially from its colour. However, the appearance of the line-structure on the spectrogram is obviously the most convincing criterion of the permanence of the substance. Thus the fact that white phosphorus gave a well-defined doublet as well as one with the longest wave-length of all phosphorus compounds showed that oxidation of the phosphorus was prevented by the above-mentioned procedure; on the other hand, a doubled doublet (one of which was identical with that of  $\text{Al}(\text{OH})_3$ ) obtained by exposing  $\text{Al}_2\text{S}_3$  indicated an impure substance to some degree spoilt by water, and therefore a purer specimen was procured.

Generally speaking, signs of a change in the sample or of an impurity in it were observed for a small number of compounds, the results of which were discarded.

<sup>8</sup> Applied X-rays, 140, 1932.

## CHAPTER 3.

### Measurements.

#### 1. Photographing the Spectra.

Suitable exposure times — each surface of the radiator being irradiated hardly more than one hour — were secured by furnishing the spectrograph with a good intensity, the demand for great dispersion not being driven too far. In reality the widths of the  $K\alpha_{1,2}$ -lines belonging to these light elements are rather large and grow from one element to another with lower atomic number, so that a dispersion of about 10 XU/mm for the elements 13 Al—16 S very well served the purpose of attaining the necessary accuracy for determining the shifts. For 11 Na and 12 Mg the line-widths are so large that the doublet-lines fuse to one diffuse line and the doublet cannot be split up; no attempt to do this has hitherto been successful. Thus a dispersion of about 20 XU/mm proved to suffice for measuring the broad Na- and Mg-lines. Still, some magnesium compounds were investigated with the spectrograph for 750 mm crystal radius giving a dispersion of about 15 XU/mm, but the greater dispersion did not result in enhanced accuracy. Data concerning the crystal grating and the dispersion in the region of the doublet are to be found in Table 3.

Some reference may here be made to the question of whether it is permissible to use as grating a gypsum crystal for sulphur measurements, a quartz crystal for silicon and a mica crystal for aluminium ones, the crystal in each case containing the element under investigation. In such cases the crystal atoms might be a source of emission of  $K\alpha$ -lines, which might disturb the normal lines on the spectrograms. Respecting this it may be said that such an excitation at second hand of these light elements must yield very weak lines, as even the radiation from the substance

TABLE 3.

Emitting atom	Crystal	Actual radius of bending mm.	Order	Dispersion XU/mm.	Reference-lines	Approximate distance between the doublet and the main reference-line mm.	Wave-length table
11 Na	Gypsum	501.6	1	19.1	Ni $K\alpha_1$ VII, Co $K\alpha_1$ VII	16	Table 4
12 Mg	Gypsum	503.8	1	22.7	Ni $K\alpha_1$ VI, Cu $K\alpha_1$ VI	2	5
12 Mg	Gypsum	755.3	1	15.2	Ni $K\alpha_1$ VI, Cu $K\alpha_1$ VI	3	6
13 Al	Mica	502.8	2	10.8	Ni $K\alpha_1$ X, Mn $K\alpha_1$ VIII, Fe $K\alpha_1$ VIII	5	7
14 Si	Quartz	502.7	1	9.3	Co $K\alpha_1$ IV, Cr $K\alpha_1$ III	3	8
15 P	Gypsum	501.7	2	8.8	Co $K\alpha_1$ VII, Ni $K\alpha_1$ VII	12	9
16 S	Gypsum	498.0	2	10.8	Co $K\alpha_1$ VI, Cu $K\alpha_1$ VII	1	10

on the radiator and from the underlying material able to excite the crystal atoms is of but very slight intensity. Experimental tests involving some hours' exposure of the crystal gratings in questions with aid of secondary fluorescent x-rays from the radiator-plates alone gave in no case traces of a  $K\alpha_{1,2}$ -doublet due to the crystal. It was likewise experimentally proved that the thin aluminium-foil between the tube and the spectrograph could be used when studying aluminium compounds too. In fact, the use of the aluminium-foil for these substances is most advantageous, the foil absorbing practically no  $K\alpha$ -radiation and re-radiating the little it does only to an inmeasurable degree.

For each element the doublet was referred to a well-defined line lying as close to it as possible on the spectrogram and preferably on its side towards longer wave-lengths so that the reference-line is free from the neighbourhood of the spark lines or satellites accompanying the doublet. (This requirement could not always be met.) Owing to the poverty of lines fit for reference in this long-waved region the distance between the doublet and the reference-line turned out rather large in two cases, amounting for sodium to about 16 mm for phosphorus to 12 mm (Table 3). The main reference-line printed in fat type in Table 3 was either the Ni  $K\alpha_1$ - or the Co  $K\alpha_1$ -line in orders up to 10. This reference-line was photographed in close connection with the exposure of the substance: one side of the radiator provided with a nickel or cobalt plate was turned in for exposure during some minutes, partly before and partly after the main exposure, in order to eliminate a possible run of the temperature during the experiment. In addition, the temperature of the room was kept constant within a range of some tenths of a degree during the whole experiment.

In order to determine the actual radius of the bending of the crystal and hence of the dispersion-curve, another reference-line was selected on the other side of the doublet, this line being taken up on a few spectrograms only. It is given in Table 3 in ordinary type. The use of mica as a grating required the exposure of still another reference-line ( $Fe K\alpha_1^{VIII}$ ) in order to test the value of the lattice-constant.

During the entire investigation of an element the spectrograph was not moved from its fixed position chosen so that the glan-

cing-angle  
well as t  
was exp  
the adju  
to the d  
photogra  
other sub  
theless t  
times, a  
of lines

As fi  
used and  
kind of

The l  
so that  
care. T  
with a c  
the ener  
x-rays,  
that the  
small. F  
not gen  
characte  
the atom  
atom, a  
number  
to I requ  
a well  
shorter  
in the s  
an hour

All s  
was pres  
through  
photome  
an incre  
blackeni

cing-angle was suitable for getting the doublet of the element as well as the reference-lines with good intensity. The pure element was exposed at first, and lastly to make sure that no change of the adjustments had taken place during the investigation. Owing to the diffuseness of the sodium and magnesium lines, these were photographed at least twice for each compound. In the case of other substances generally only one spectrogram was taken. Nevertheless the exposure of some compounds had to be repeated several times, as the spectrograms were not satisfactory, e. g., because of lines too weak to be measured.

As film material Agfa Laue Film covered on only one side was used and the developer was that specially recommended for this kind of film.

The load on the tube was to some degree suited to the specimen, so that a relatively unstable compound was exposed with some care. The tube was run with a high-tension of 25—30 kV and with a current of 25—30 mA. We have seen that only a part of the energy of the primary radiation is transformed into fluorescent x-rays, which in the second place are spread in all directions so that their intensity in the direction of the crystal grating is very small. However, with the load mentioned, the exposure times did not generally exceed 4 hours. The intensity of the fluorescent characteristic rays is *inter alia*, determined by self-absorption of the atoms entering in the molecule together with the emitting atom, and this absorption increases rapidly with the atomic number of these atoms. For instance, the Na-atom when bound to I required an exceptionally long exposure. For the pure element a well exposed spectrogram could be obtained in considerably shorter time than for the compounds: metallic magnesium was in the smallest dispersion photographed only for a quarter of an hour.

All spectrograms were measured in the comparator. The film was pressed between two metal plates, each with a slit  $5 \times 20$  mm through which the spectrogram was visible. The use of microphotometric recording of the Na- and Mg-lines may not involve an increased accuracy, as the lines present themselves as flat blackenings on the spectrograms.

## 2. The Wave-lengths.

The wave-lengths  $\lambda$  of the  $K\alpha_{1,2}$ -doublet computed from the measurements are given in Tables 4—10. They often represent the average value of two or more measurements which generally differ very little between themselves. Lattice-constants, wave-

TABLE 4. The Na  $K\alpha_{1,2}$ -line. Disp. 19.1 XU/mm.

Substance	$\lambda$	$r/R$
Na	11885.8	76.668
NaF	85.0	6.674
NaCl	84.5	6.677
NaBr	84.7	6.676
NaJ	84.8	6.675
NaOH	84.9	6.674
Na <sub>2</sub> SiO <sub>3</sub>	84.8	6.675
Na <sub>2</sub> PO <sub>4</sub>	84.6	6.676
Na <sub>2</sub> SO <sub>4</sub>	84.4	6.677
NaClO <sub>4</sub>	83.9	6.681
Na <sub>2</sub> S	84.8	6.675
NaN <sub>3</sub>	85.3	6.672
NaP <sub>3</sub>	85.2	6.672
Na <sub>2</sub> C <sub>2</sub>	85.3	6.672
Na <sub>2</sub> Sn	85.3	6.672
NaCd <sub>2</sub>	85.5	6.670

lengths of the reference-lines, and corrections for anomalous dispersion were taken from M. Siegbahn, *Spektroskopie der Röntgenstrahlen*. For the aluminium investigation a crystal of Indian potassic mica was used. The determined lattice-constant agreed closely with that obtained by A. Larsson<sup>1</sup> for the same

<sup>1</sup> Diss. Upsala 1929.

TABLE 5. The Mg  $K\alpha_{1,2}$ -line. Disp. 22.7 XU mm

Substance	$\Delta\lambda$	$\nu/R$
Mg	9869.9	92.328
MgF <sub>2</sub>	67.9	2.346
MgSiF <sub>6</sub>	67.8	2.347
MgCl <sub>2</sub>	67.6	2.349
MgBr <sub>2</sub>	67.8	2.347
MgO	68.4	2.342
Mg(OH) <sub>2</sub>	68.2	2.343
MgCO <sub>3</sub>	68.3	2.343
MgSiO <sub>3</sub>	68.5	2.341
Mg <sub>3</sub> (PO <sub>4</sub> ) <sub>2</sub>	68.4	2.342
MgSO <sub>4</sub>	68.2	2.343
Mg(ClO <sub>4</sub> ) <sub>2</sub>	67.6	2.349
Al <sub>2</sub> (MgO <sub>4</sub> )	68.9	2.337
MgS	68.4	2.342
Mg <sub>3</sub> N <sub>2</sub>	69.3	2.333
Mg <sub>3</sub> P <sub>2</sub>	69.1	2.335
Mg <sub>2</sub> C	69.5	2.332
Mg <sub>2</sub> Si	69.5	2.332
Mg <sub>2</sub> Sn	69.5	2.332

kind of mica. For calculating the Al  $K\alpha_{1,2}$  wave-lengths, Larsson's value as being certainly the most accurate one was employed. Following Ph. Haglund's<sup>2</sup> procedure, no correction for anomalous dispersion in mica was applied to the Al  $K\alpha_{1,2}$  wave-lengths. The tables also give the value of  $\nu/R$  for each line and the doublet distance  $\Delta\lambda$ , if this has been measured. The value  $R = 109737.42$  was employed.

Each table shows from the top downwards the results for compounds in which the emitting atom as cation is linked to a monovalent anion, a bivalent anion, etc.; lowest in the table the wave-lengths of the elements as anions are to be found.

<sup>2</sup> ZS f. Phys. 94, 369, 1935.

TABLE 6. The Mg  $K\alpha_{1,2}$ -line. Disp. 15.2 XU/mm.

Substance	$\lambda$	$\nu/R$
Mg	9869.9	92.328
MgF <sub>2</sub>	68.0	2.345
MgCl <sub>2</sub> · 6H <sub>2</sub> O	67.5	2.350
MgO	68.6	2.340
Mg <sub>3</sub> P <sub>2</sub>	69.2	2.334
Mg <sub>2</sub> C	69.3	2.333
Mg <sub>3</sub> B <sub>2</sub>	69.4	2.333
Mg <sub>4</sub> Al <sub>3</sub>	69.7	2.330

O. Stelling<sup>3</sup> found on the K absorption limit of chlorine in various chlorides a small effect apparently due to water of crystallization. It is not expected that the L-levels of our elements could be subject to such an influence to any measurable degree. A direct experimental comparison between MgCl<sub>2</sub> and MgCl<sub>2</sub> · 6 H<sub>2</sub>O seemed to verify this assumption, as these two compounds gave the same wave-lengths. In the tables the number of water molecules in the compounds has not been set out, all the more so as this number often decreases during the exposure because of the vacuum.

Precision measurements of the  $K\alpha_{1,2}$ -doublets of the pure elements 11 Na—16 S were made, except those carried out by Lundquist and Faessler, by the method of electron impact excitation, which is attended with some risk of a slight oxidation of the element with a consequent disturbance of its doublet by the oxide doublet. In fact, the method of secondary fluorescent x-rays might be advisable for the precision measurements of these elements. In Table 11 the wave-lengths and doublet distances resulting from the most recent researches are compared with the results of this investigation. Metallic sodium and white phosphorus have not been exposed by others. E. Hjalmar found for NaCl a value, 11885 XU

<sup>3</sup> Diss. Lund 1927.

Al
AlF <sub>3</sub>
Na <sub>3</sub> Al
AlCl <sub>3</sub>
Al <sub>2</sub> O <sub>3</sub>
Al(OH) <sub>3</sub>
Be <sub>3</sub> Al
AlPO <sub>4</sub>
Al <sub>2</sub> (S)
Al(Cl)
Al(N)
Al <sub>2</sub> (M)
Al <sub>2</sub> (M)
K(Al)
Ca(A)
Na <sub>2</sub> A
Na <sub>3</sub> A
Al <sub>2</sub> S <sub>3</sub>
Al <sub>2</sub> Se
Al <sub>2</sub> T
AlN
AlP
Al <sub>4</sub> C <sub>3</sub>
AlB <sub>2</sub>
Mg <sub>4</sub> A

in go  
Lund  
shifts  
phosp  
agree

TABLE 7. The Al  $K\alpha_{1,2}$ -doublet. Disp. 10.8 XU/mm.

Substance	$K\alpha_1$		$K\alpha_2$		$\Delta\lambda$
	$\lambda$	$\nu/R$	$\lambda$	$\nu/R$	
Al	8321.87	109.503	8324.39	109.470	2.52
AlF <sub>3</sub>	18.95	9.541	21.49	9.508	2.54
Na <sub>3</sub> AlF <sub>6</sub>	18.99	9.541	21.49	9.508	2.50
AlCl <sub>3</sub>	19.22	9.537	21.71	9.505	2.49
Al <sub>2</sub> O <sub>3</sub>	19.87	9.529	22.32	9.497	2.45
Al(OH) <sub>3</sub>	19.73	9.531	22.24	9.498	2.51
Be <sub>3</sub> Al <sub>2</sub> (Si <sub>6</sub> O <sub>18</sub> ), beryl	19.72	9.531	22.17	9.499	2.45
AlPO <sub>4</sub>	19.70	9.531	22.09	9.500	2.39
Al <sub>2</sub> (SO <sub>4</sub> ) <sub>3</sub>	19.43	9.534	21.80	9.504	2.37
Al(ClO <sub>4</sub> ) <sub>3</sub>	19.21	9.537	21.68	9.505	2.47
Al(NO <sub>3</sub> ) <sub>3</sub>	19.20	9.537	21.56	9.507	2.36
Al <sub>2</sub> (MgO <sub>4</sub> ), red spinel	19.83	9.529	22.44	9.495	2.61
Al <sub>2</sub> (MgO <sub>4</sub> ), black spinel	19.88	9.529	22.38	9.496	2.50
K(AlSi <sub>3</sub> O <sub>8</sub> ), orthoclase	20.14	9.525	22.63	9.493	2.49
Ca(Al <sub>2</sub> Si <sub>2</sub> O <sub>8</sub> ), anorthite	20.38	9.522	22.95	9.489	2.57
Na <sub>2</sub> Al <sub>2</sub> O <sub>4</sub>	20.56	9.520	23.08	9.487	2.52
Na <sub>3</sub> AlO <sub>3</sub>	20.67	9.518	23.13	9.486	2.46
Al <sub>2</sub> S <sub>3</sub>	20.36	9.522	22.90	9.489	2.54
Al <sub>2</sub> Se <sub>3</sub>	20.04	9.526	22.57	9.494	2.53
Al <sub>2</sub> Te <sub>3</sub>	20.03	9.526	22.55	9.494	2.52
AlN	20.29	9.523	22.74	9.491	2.45
AlP	21.01	9.514	23.46	9.482	2.45
Al <sub>4</sub> C <sub>3</sub>	21.18	9.512	23.63	9.480	2.45
AlB <sub>12</sub>	20.58	9.520	23.07	9.487	2.49
Mg <sub>4</sub> Al <sub>3</sub>	22.24	9.498	24.85	9.463	2.61

in good agreement with that accruing from this investigation. Lundquist, when studying the P  $K\alpha_{1,2}$ -doublet, determined the shifts in relation to red phosphorus. I found the doublet of white phosphorus to be a little longer-waved than that of the red. The agreement between mine and earlier measurements is satisfactory;

TABLE 8. The Si  $K\alpha_{1,2}$ -doublet. Disp. 9.3 XU/mm.

Substance	$K\alpha_1$		$K\alpha_2$		$\Delta\lambda$
	$\lambda$	$\nu/R$	$\lambda$	$\nu/R$	
Si	7110.94	128.150	7113.58	128.102	2.64
$\text{Na}_2\text{SiF}_6$	07.37	8.214	09.99	8.167	2.62
$\text{Mg}_2\text{SiF}_6$	07.40	8.213	10.10	8.165	2.70
$\text{SiO}_2$	08.43	8.195	11.16	8.146	2.73
$\text{SiO}_2 \cdot n\text{H}_2\text{O}$	08.53	8.193	11.25	8.144	2.72
$\text{Na}_2\text{SiO}_3$	08.53	8.193	11.24	8.145	2.71
$\text{Mg}_2\text{SiO}_4$ , forsterite	08.46	8.194	11.11	8.147	2.65
$\text{Be}_3\text{Al}_2(\text{Si}_5\text{O}_{18})$ , beryl	08.49	8.194	11.21	8.145	2.72
$[\text{Al}(\text{F}, \text{OH})_2\text{SiO}_4]$ , topaz	08.48	8.194	11.20	8.145	2.72
$\text{KAl}_2(\text{OH})_2[\text{Si}_3\text{AlO}_{10}]$ , muscovite	08.77	8.189	11.40	8.142	2.63
$\text{CaAl}_2(\text{OH})_2[\text{Si}_2\text{Al}_2\text{O}_{10}]$ , margarite	08.61	8.191	11.30	8.143	2.69
$\text{K}(\text{AlSi}_3\text{O}_8)$ , orthoclase	08.64	8.191	11.31	8.143	2.67
$\text{Ca}(\text{Al}_2\text{Si}_2\text{O}_8)$ , anorthite	08.76	8.189	11.44	8.141	2.68
$\text{SiS}_2$	08.89	8.186	11.56	8.139	2.67
$\text{Si}_3\text{N}_4$	08.96	8.185	11.58	8.138	2.62
SiC	10.07	8.165	12.67	8.119	2.60
$\text{Mg}_2\text{Si}$	11.52	8.139	14.26	8.090	2.74

we must consider that an error in the wave-lengths of the reference-lines comes in enlarged in the determined wave-lengths. Therefore, the values found by Haglund from absolute measurements are, undoubtedly, the most accurate.

It will be clear from Fig. 4, which shows microphotometric records of the doublets of the pure elements, that the doublet-lines overlap more and more from 16 S to 11 Na. The measuring of the doublet was easy to accomplish for 14 Si—16 S, but met with some difficulty for 13 Al, where the doublet is not very clearly split up. The determination of the Al doublet distance in the comparator is possibly affected with a systematic error

<sup>4</sup> ZS f. Phys. 1, 439, 1920.

<sup>5</sup> L. c.

<sup>6</sup> ZS f. Phys. 102, 768, 1936.

3 XU/mm.

$K\alpha_2$		$\Delta\lambda$
	$\nu/R$	
58	128.102	2.64
99	8.167	2.62
10	8.165	2.70
16	8.146	2.73
25	8.144	2.72
24	8.145	2.71
11	8.147	2.65
21	8.145	2.72
20	8.145	2.72
40	8.142	2.63
30	8.143	2.69
31	8.143	2.67
44	8.141	2.68
56	8.139	2.67
58	8.138	2.62
67	8.119	2.60
26	8.090	2.74

s of the reference-  
re-lengths. There-  
ute measurements

microphotometric  
that the doublet-  
a. The measuring  
Si—16 S, but met  
blet is not very  
doublet distance in  
systematic error

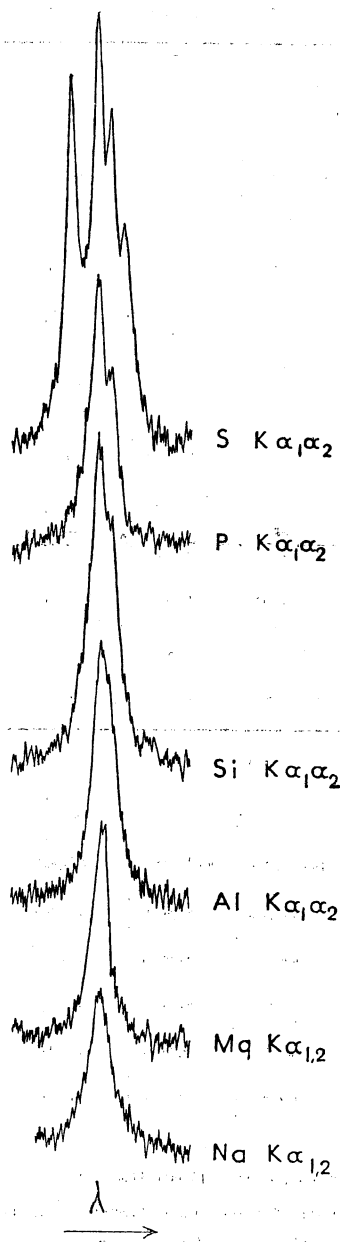

Fig. 4. The  $K\alpha_{1,2}$ -doublets of the pure elements. (The  $S K\alpha_{1,2}$  is flanked by the  $Co K\alpha_1$  and the  $Co K\alpha_2$ .)

TABLE 9. The  $PK\alpha_{1,2}$ -doublet. Disp. 8.8 XU/mm.

Substance	$K\alpha_1$		$K\alpha_2$		$\Delta\lambda$
	$\lambda$	$\nu/R$	$\lambda$	$\nu/R$	
P white	6143.83	148.322	6146.56	148.256	2.73
P red	43.73	8.325	46.40	8.260	2.67
P metallic	43.69	8.326	46.38	8.260	2.69
$P_2S_5$	42.96	8.343	45.66	8.278	2.70
$P_2S_8$	43.25	8.336	45.92	8.271	2.67
$P_4S_3$	43.58	8.328	46.36	8.261	2.78
$P_3N_5$	41.92	8.369	44.62	8.303	2.70
$NaP_3$	43.89	8.321	46.53	8.257	2.64
$Mg_3P_2$	44.34	8.310	47.10	8.242	2.76
AlP	44.58	8.304	47.32	8.238	2.74

TABLE 10. The  $SK\alpha_{1,2}$ -doublet. Disp. 10.8 XU/mm.

Substance	$K\alpha_1$		$K\alpha_2$		$\Delta\lambda$
	$\lambda$	$\nu/R$	$\lambda$	$\nu/R$	
S	5360.83	169.986	5363.69	169.895	2.86
$Na_2S$	61.30	9.971	64.10	9.882	2.80
$SiS_2$	61.22	9.974	64.05	9.884	2.83
$P_2S_5$	61.25	9.973	64.06	9.883	2.81
$P_2S_8$	61.13	9.976	63.95	9.887	2.82
$P_4S_3$	61.10	9.977	63.95	9.887	2.85

according to a statement by Bäcklin,<sup>7</sup> who, when measuring the Al  $K\alpha_{1,2}$ -doublet, pointed out that there is a tendency to overrate the distance between the two lines lying close to each other.

<sup>7</sup> ZS f. Phys. 33, 547, 1925.

XU/mm.

$\nu/R$	$\Delta\lambda$
8.256	2.73
8.260	2.67
8.260	2.69
8.278	2.70
8.271	2.67
8.261	2.78
8.303	2.70
8.257	2.64
8.242	2.76
8.238	2.74

TABLE 11. The wave-lengths of the  $K\alpha_{1,2}$  doublet of the pure elements and the doublet distances  $\Delta\lambda$  compared with earlier measurements.

Emitting element		This invest.	Earlier invest.		This invest.	Earlier invest.
11 Na	$\alpha_{1,2}$	11885.8				
12 Mg	$\alpha_{1,2}$	9869.9	9869.0 Hjalmar <sup>4</sup>			
13 Al	$\alpha_2$	8324.39	8324.62	$\Delta\lambda$	2.52	2.44 Haglund
	$\alpha_1$	8321.87	8322.18 Haglund <sup>5</sup>			
14 Si	$\alpha_2$	7113.58	7113.18	$\Delta\lambda$	2.64	2.52 Haglund
	$\alpha_1$	7110.94	7110.66 Haglund			
15 P white	$\alpha_2$	6146.56		$\Delta\lambda$	2.73	
	$\alpha_1$	6143.83				
15 P red	$\alpha_2$	6146.40	6146.78	$\Delta\lambda$	2.67	2.67 Lundquist
	$\alpha_1$	6143.73	6144.11 Lundquist <sup>6</sup>			
16 S	$\alpha_2$	5363.69	5363.92	$\Delta\lambda$	2.86	2.82 Haglund
	$\alpha_1$	5360.83	5361.10 Haglund			

TABLE 12. The shifts of the  $NaK\alpha_{1,2}$  line.

Substance	$\delta\lambda$ XU	$\delta V$ Volts
NaF	-0.8	-0.07
NaCl	1.3	0.11
NaBr	1.1	0.10
NaJ	1.0	0.09
NaOH	0.9	0.08
Na <sub>2</sub> SiO <sub>3</sub>	1.0	0.09
Na <sub>3</sub> PO <sub>4</sub>	1.2	0.11
Na <sub>2</sub> SO <sub>4</sub>	1.4	0.12
NaClO <sub>4</sub>	1.9	0.17
Na <sub>2</sub> S	1.0	0.09
NaN <sub>3</sub>	0.5	0.04
NaP <sub>3</sub>	0.6	0.05
Na <sub>2</sub> C <sub>2</sub>	0.5	0.04
Na <sub>4</sub> Sn	0.5	0.04
NaCd <sub>2</sub>	0.3	0.03

XU/mm.

$\nu/R$	$\Delta\lambda$
9.895	2.86
9.882	2.80
9.884	2.83
9.883	2.81
9.887	2.82
9.887	2.85

en measuring the  
endency to overrate  
o each other.

## 3. The Widths of the Lines.

The influence of chemical combination on the  $K\alpha_{1,2}$ -doublet of the elements 11 Na—16 S is primarily apparent through a shift of the doublet. However, it is well known that the emission lines of free atoms broaden when the atoms are joined in a crystal lattice, and hence the widths of the lines might not be the same in different crystals. According to H. Frölich's theory<sup>8</sup> for metals

TABLE 13. The shifts of the Mg  $K\alpha_{1,2}$ -line.

Substance	$\delta\lambda$ XU	$\delta V$ Volts
MgF <sub>2</sub>	-2.0	-0.25
MgF <sub>2</sub>	1.9	
MgSiF <sub>6</sub>	2.1	
MgCl <sub>2</sub>	2.3	0.30
MgCl <sub>2</sub> · 6H <sub>2</sub> O	2.4	
MgBr <sub>2</sub>	2.1	0.27
MgO	1.5	0.19
MgO	1.3	
Mg(OH) <sub>2</sub>	1.7	
MgCO <sub>3</sub>	1.6	0.20
MgSiO <sub>3</sub>	1.4	0.18
Mg <sub>3</sub> (PO <sub>4</sub> ) <sub>2</sub>	1.5	0.19
MgSO <sub>4</sub>	1.7	0.22
Mg(ClO <sub>4</sub> ) <sub>2</sub>	2.3	0.29
Al <sub>2</sub> (MgO <sub>4</sub> )	1.0	0.13
MgS	1.5	0.19
Mg <sub>3</sub> N <sub>2</sub>	0.6	0.08
Mg <sub>3</sub> P <sub>2</sub>	0.8	0.10
Mg <sub>3</sub> P <sub>2</sub>	0.7	
Mg <sub>2</sub> C	0.4	0.06
Mg <sub>2</sub> C	0.6	
Mg <sub>2</sub> Si	0.4	0.05
Mg <sub>2</sub> Sn	0.4	0.05
Mg <sub>3</sub> B <sub>2</sub>	0.5	0.06
Mg <sub>4</sub> Al <sub>3</sub>	0.2	0.03

<sup>8</sup> Elektronentheorie der Metalle, Berlin, Jul. Springer, 1936.

an e  
outer  
when  
metr  
fact,  
from

TABLE 14. The shifts of the Al  $K\alpha_{1,2}$ -doublet.

Substance	$\delta\lambda$ XU		$\delta V$ Volts
	$K\alpha_1$	$K\alpha_2$	
AlF <sub>3</sub>	-2.92	-2.90	-0.52
Na <sub>3</sub> AlF <sub>6</sub>	2.88	2.90	
AlCl <sub>3</sub>	2.65	2.68	0.48
Al <sub>2</sub> O <sub>3</sub>	2.00	2.07	0.37
Al(OH) <sub>3</sub>	2.14	2.15	
Be <sub>3</sub> Al <sub>2</sub> (Si <sub>6</sub> O <sub>18</sub> ), beryl	2.15	2.22	0.39
AlPO <sub>4</sub>	2.17	2.30	0.40
Al <sub>2</sub> (SO <sub>4</sub> ) <sub>3</sub>	2.44	2.59	0.45
Al(ClO <sub>4</sub> ) <sub>3</sub>	2.66	2.71	0.48
Al(NO <sub>3</sub> ) <sub>3</sub>	2.67	2.83	0.49
Al <sub>2</sub> (MgO <sub>4</sub> ), red spinel	2.04	1.95	0.36
Al <sub>2</sub> (MgO <sub>4</sub> ), black spinel	1.99	2.01	
K(AlSi <sub>3</sub> O <sub>8</sub> ), orthoclase	1.73	1.76	0.31
Ca(Al <sub>2</sub> Si <sub>2</sub> O <sub>8</sub> ), anorthite	1.49	1.44	0.26
Na <sub>2</sub> Al <sub>2</sub> O <sub>4</sub>	1.31	1.31	0.23
Na <sub>3</sub> AlO <sub>3</sub>	1.20	1.26	
Al <sub>2</sub> S <sub>3</sub>	1.51	1.49	0.27
Al <sub>2</sub> Se <sub>3</sub>	1.83	1.82	0.33
Al <sub>2</sub> Te <sub>3</sub>	1.84	1.84	0.33
AlN	1.58	1.65	0.29
AlP	0.86	0.93	0.16
Al <sub>4</sub> C <sub>3</sub>	0.69	0.76	0.13
AlB <sub>12</sub>	1.29	1.32	-0.23
Mg <sub>4</sub> Al <sub>3</sub>	+0.37	+0.46	+0.07

an emission line arising from transition of an electron from a full outer group to one of the inner groups is symmetrical, whereas, when the outer group is not completed the line becomes asymmetrical showing a sharp edge towards shorter wave-lengths. In fact, we must expect the  $K\alpha_{1,2}$ -lines, which originate when electrons from the full L-shell fall to the K-shell, to be fairly symmetrical

TABLE 15. The shifts of the Si K  $\alpha_{1,2}$ -doublet.

Substance	$\delta\lambda$ XU		$\delta V$ Volts
	K $\alpha_1$	K $\alpha_2$	
Na <sub>2</sub> SiF <sub>6</sub> MgSiF <sub>6</sub>	-3.57 3.54	-3.59 3.48	-0.87
SiO <sub>2</sub> SiO <sub>2</sub> · nH <sub>2</sub> O Na <sub>2</sub> SiO <sub>3</sub> Mg <sub>2</sub> SiO <sub>4</sub> , forsterite Be <sub>3</sub> Al <sub>2</sub> (Si <sub>6</sub> O <sub>18</sub> ), beryl [Al(F, OH)] <sub>2</sub> SiO <sub>4</sub> , topaz	2.51 2.41 2.41 2.48 2.45 2.46	2.42 2.33 2.34 2.47 2.37 2.38	0.59
KAl <sub>2</sub> (OH) <sub>2</sub> [Si <sub>3</sub> AlO <sub>10</sub> ], muscovite CaAl <sub>2</sub> (OH) <sub>2</sub> [Si <sub>2</sub> Al <sub>2</sub> O <sub>10</sub> ], margarite K(AlSi <sub>3</sub> O <sub>8</sub> ), orthoclase Ca(Al <sub>2</sub> Si <sub>2</sub> O <sub>8</sub> ), anorthite	2.17 2.33 2.30 2.18	2.18 2.28 2.27 2.14	0.55
SiS <sub>2</sub>	2.05	2.02	0.50
Si <sub>3</sub> N <sub>4</sub>	1.98	2.00	0.49
SiC	0.87	0.91	0.22
Mg <sub>2</sub> Si	+0.58	+0.68	+0.15

disregarding the slight asymmetry characterizing all K lines.<sup>9</sup> A simple photographing and microphotometric recording of the lines is not the method for studying the shapes and widths of the lines. An experimental arrangement more suited for the purpose is offered by the double crystal spectrometer. This was, for instance, used by L. Obert and J. A. Bearden,<sup>9</sup> who studied the width and index of asymmetry of the fluorescent K $\alpha_1$ , K $\alpha_2$  and K $\beta_1$  emission lines of pure Zn, Cu, Fe, Mn, Cr and many compounds. They conclude that the change in the widths of the K $\alpha$  lines must be due to a change in the width of the L-levels, as the width of the K-level is evidently not influenced by chemical combination. However, the necessity of producing fluorescent radiation of sufficient intensity renders difficult the application of the method to the lighter elements.

As to the widths of the lines for 11 Na—16 S, which increase with decreasing atomic number, this investigation shows that the

<sup>9</sup> Phys. Rev. 54, 1000, 1938.

-doublet.

$K\alpha_2$	$\delta V$ Volts
-3.59 3.48	-0.87
2.42 2.33 2.34 2.47 2.37 2.38	0.59
2.18 2.28 2.27 2.14	0.55
2.02	0.50
2.00	0.49
0.91	0.22
0.68	+0.15

ing all K lines.<sup>9</sup> A  
ording of the lines  
widths of the lines.  
or the purpose is  
s was, for instance,  
lied the width and  
and  $K\beta_1$  emission  
compounds. They  
 $K\alpha$  lines must be  
s the width of the  
ical combination.  
cent radiation of  
ion of the method

S, which increase  
on shows that the

TABLE 16. The shifts of the P  $K\alpha_{1,2}$ -doublet.

Substance	$\delta\lambda$ XU		$\delta V$ Volts
	$K\alpha_1$	$K\alpha_2$	
P red	-0.10	-0.16	-0.04
P metallic	0.14	0.18	0.05
$P_2S_5$	0.87	0.90	0.29
$P_2S_3$	0.58	0.64	0.20
$P_4S_3$	0.25	0.20	0.07
$P_3N_5$	1.91	1.94	0.63
NaP	+0.07	-0.03	+0.01
$Mg_3P_2$	+0.51	+0.54	+0.17
AlP	+0.85	+0.92	+0.29

TABLE 17. The shifts of the S  $K\alpha_{1,2}$ -doublet.

Substance	$\delta\lambda$ XU		$\delta V$ Volts
	$K\alpha_1$	$K\alpha_2$	
$Na_2S$	+0.47	+0.41	+0.19
$SiS_2$	0.39	0.36	0.16
$P_2S_5$	0.42	0.37	0.17
$P_2S_3$	0.30	0.26	0.12
$P_4S_3$	0.27	0.26	0.11

lines of the compounds seem to be wider than those of the pure element, though this effect is not very conspicuous. For the rest we desist from entering upon the subject.

#### 4. The Shifts.

It may be emphasized that the primary purpose of this investigation is not to give a precision measurement of the absolute

wave-lengths but to study the shifts caused by chemical combination. The shifts in relation to the pure element are given in Tables 12—17, which are arranged in the same manner as the wave-length tables, though the Mg-tables 5 and 6 are brought together in one (Table 13). For each compound the shifts  $\delta\lambda$  of the two doublet-lines are presented in XU. The minus sign indicates a shift towards shorter wave-lengths, the plus sign a shift towards longer wave-lengths. This investigation, like earlier ones, has not brought to light any evidence that the shifts of the two doublet-lines are not the same. We, therefore, take a mean value of them as representing the change of the doublet in a certain compound. This shift of the doublet  $\delta V$  is given in electron-volts in the last column of the tables. For compounds the shifts of which agree within limits of error an average value has been computed.

The small number of shifts determined by other investigators agree well with these measurements. Thus Bäcklin<sup>10</sup> found shifts of 0.57 volts for  $\text{SiO}_2$  and 0.31 for  $\text{Al}_2\text{O}_3$ . Flemberg<sup>10</sup> gave 0.58 volts for  $\text{SiO}_2$  and 0.22 for  $\text{SiC}$ .

To illustrate the shifts some comparisons between one or two spectrograms of compounds of an element and a spectrogram of the pure element itself are reproduced on Plates I—III. The spectrograms showing the same doublet are enlarged (enlargement about 4) exactly to the same scale and placed in relation to each other so that the reference-lines coincide.

### 5. The Accuracy of the Measurements.

We need not dwell on the errors with which the use of a concave crystal grating is associated. Sandström<sup>11</sup> has given a detailed description of all systematic errors. He states that the inevitable focussing-defect can be made to counterbalance the broadening-effect caused by the oblique penetration of the x-rays in the photographic emulsion, as these effects go in opposite directions. Hence the lines are symmetrically broadened, the distribution of the blackening on the spectrogram being approxi-

<sup>10</sup> See p. 7 and 9.

<sup>11</sup> Diss. Upsala 1935.

mately ga  
broadening  
case the re  
the emulsi  
Laue film  
back of th  
highly abs  
blackening  
surface of  
piece of so  
tion of sym  
of these li  
natural wi  
rent penet  
must imply  
wave-length  
photograph  
of the ray  
shifts the  
doublets o  
element, a  
have aime  
exposures.  
racy of th  
The me  
in the wa  
series 11  
tainty of  
mean valu  
naturally

mately gaussian. Some interest may here be directed to the broadening-effect due to the thickness of the emulsion. In any case the reference-lines are well exposed, so that they penetrate the emulsion thoroughly, which could be shown by using Agfa Laue film covered on both sides, the lines appearing then on the back of the film too. On the contrary, the soft  $K\alpha$  radiation is highly absorbed in the emulsion containing heavy atoms: a normal blackening for instance of the Mg-lines was seated in the very surface of the emulsion and could easily be wiped away with a piece of soft cloth. The conditions underlying Sandström's assumption of symmetrical broadening are not present in the case of lines of these light elements. This, however, is not important, as the natural widths of the lines are considerable. Obviously the different penetration of the reference-lines and of the doublet-lines must imply a systematic error in the determination of the absolute wave-lengths. By using film with thin emulsion ( $12 \mu$ ), and by photographing at great glancing-angles so that the obliquity of the rays is small, the error could be greatly reduced. In the *shifts* the uncertainty is due to the different penetration of the doublets of the compounds and of the doublet of the pure element, and it can be quite disregarded, all the more so as I have aimed at giving all lines the same intensity by timing the exposures. The focussing-defect is not important for the accuracy of the shifts, as it is about the same for all doublet-lines.

The measuring of the spectrograms involves an uncertainty in the wave-lengths, which decreases from left to right in the series 11 Na—16 S. Generally we can reckon with an uncertainty of about  $\pm 0.04$  volts for all shifts. The accuracy of a mean value of several shifts (See for example the silicates) is naturally greater.

chemical combina-  
ent are given in  
e manner as the  
d 6 are brought  
d the shifts  $\delta\lambda$  of  
The minus sign  
the plus sign a  
ation, like earlier  
the shifts of the  
ore, take a mean  
the doublet in a  
 $\delta V$  is given in  
For compounds  
an average value

ther investigators  
lin<sup>10</sup> found shifts  
berg<sup>10</sup> gave 0.58

etween one or two  
a spectrogram of  
ates I—III. The  
ged (enlargement  
a relation to each

ments.

ch the use of a  
m<sup>11</sup> has given a  
e states that the  
unterbalance the  
ion of the x-rays  
go in opposite  
broadened, the  
m being approxi-

## CHAPTER 4.

### X-Rays and Interaction between Atoms.

#### 1. Chemical Combination and Crystal Types.

Before entering on a discussion of the effects of chemical combination on x-ray spectra we shall briefly outline the present knowledge of the chemical forces between atoms. The old valency theory of chemistry was not very interesting from a physical point of view, as it could not explain anything about the actual mechanism of chemical combination. W. Kossel<sup>1</sup> was the first to give an elaborated theory. He interprets the ionic bond as electrostatic interaction between positively and negatively charged particles. For instance, when a gaseous NaCl-molecule is being formed the 3s electron or the valency electron of Na is added to the M-shell of Cl, rendering this an 8 electron shell, and the two ions, which can roughly be considered as spherical, are attracted to each other by Coulombic forces until they almost touch each other and the attraction is balanced by repulsion between the outer shells, the nuclear distance being the sum of the radii of the two ions. A theory for the homopolar binding was given by W. Heitler and F. London.<sup>2</sup> Their theoretical treatment is based on the Schrödinger equation and the Pauli principle. According to their conception, two atoms are linked to each other by means of an electron pair rotating round the two nuclei. Electrons from the two atoms can only attach themselves to such a pair of electrons when they have antiparallel spins; the spin vectors of the two electrons balance each other in the state of attraction and are summated in the state of repulsion. In systems of two or several atoms the number of free spins will correspond

<sup>1</sup> Ann. d. Phys. 49, 229, 1916.

<sup>2</sup> See Handb. d. Phys. 24/2, 756, 1933.

to the valencies. The theory is able to explain forms of transition between typical heteropolar and typical homopolar combination. — The interpretation of the chemical bond has also been furthered by Slater—Pauling and by Herzberg—Hund—Mulliken, whose methods admit to some extent of a systematizing of the binding types.

A study of the interaction between atoms must take polarization phenomena into account. It is easily understood that if a large diffuse negative ion such as  $S^-$  combines with a small positive ion it must be distorted; in every ion a dipole originates and the two dipoles impart electrostatic forces to each other. Polarization is much stronger for negative than for positive ions, decreases from left to right for elements in the same periodic row, but increases with the atomic number of elements in the same periodic column. It is considered that increasing polarization gradually merges with homopolar binding so that the transformation of ionic combination into homopolar implies increased polarization of the ions.

According to the type of combination all crystalline compounds can, broadly speaking, be classed under four main types: ionic or heteropolar, homopolar, molecular, and metallic. Naturally many substances must be referred to intermediate forms of two or more of these types. The typical ionic compounds (NaCl) are common, whereas the homopolar compounds, including in the first place crystals of diamond type (SiC), are more sparingly found. Substances with the latter structure are either insulators (SiC), characterized by very high melting point and by great hardness, or they are metals (Si). In the molecular crystals the pattern units are whole molecules in which the atoms are linked to each other by more or less typical homopolar bonds; the molecules are held together in the lattice by van der Waal's forces, or residual electric fields between molecular poles. Organic compounds, and many inorganic compounds such as  $AlCl_3$  and  $SiF_4$ , belong to the molecular type, which has the properties of very low melting point and low hardness. Finally, in metallic combination, which occurs when atoms lose electrons easily, the crystal units are positive ions held together by an electron gas.

## 2. The Appearing of Chemical Effects on X-ray Spectra.

In Table 18 the electronic structures of the free elements 1 H—54 Xe are tabulated. The L shell is completed with 10 Ne. With increasing atomic number; firstly the  $M_I$ -level is occupied by two electrons (3s) and then the  $M_{II,III}$ -levels are supplied with in all six electrons (3p). Thus in the series 11 Na—17 Cl a new 8-electron shell is built up from one rare gas, 10 Ne, to another 18 A. The valency electrons or the electrons outside the L shell are in number from 1 for 11 Na to 7 for 17 Cl. The emission lines  $K\alpha_1$  and  $K\alpha_2$  are produced when a 1s-electron is removed and the vacancy filled by 2p-electrons from the  $L_{III}$  and the  $L_{II}$ -level respectively. When the emitting atom is linked to another atom through the valency-electrons, the frequency of the  $K\alpha_{1,2}$ -radiation is modified in the first place because of a change of the  $L_{II,III}$ -levels. Bäcklin<sup>3</sup> pointed out that the K-level, which is screened off by the eight L-electrons, must be but very little influenced by the chemical combination. The difference in energy states between the two levels  $L_{II}$  and  $L_{III}$  is small, not exceeding 1 % of the absolute values of their energies; and the effect on the two L-levels might be almost equal. Nor could the experiments reveal a different change of the  $K\alpha_1$  and the  $K\alpha_2$  line.

An effect of chemical combination on the  $K\alpha_{1,2}$ -doublet occurs in the case of elements lighter than 18 A: in the series 11 Na—17 Cl, in which the L-shell is complete, it appears as a shift of the doublet as such, whereas for elements lighter than 10 Ne, the L-shells of which are not filled, the influence is more apparent as a change in the shape and width of the broad lines.<sup>4</sup> For 19 K and for elements with a higher atomic number the  $L_{II,III}$ -levels seem to be unaffected by the chemical bonds, probably owing to the screening effect of the 8-electron shell outside the L-levels. Still, in these elements there is an influence on the outer levels. Thus A. Lindh<sup>5</sup> found an effect on the K absorption edges of the

<sup>3</sup> ZS f. Phys. 38, 215, 1926.

<sup>4</sup> See M. Siegbahn and T. Magnusson, ZS f. Phys. 37, 291, 1934.

<sup>5</sup> See M. Siegbahn, Spektroskopie der Röntgenstrahlen.

TAB

X-ray level	Type of orbit
1 H	
2 He	
3 Li	
4 Be	
5 B	
6 C	
7 N	
8 O	
9 F	
10 Ne	
11 Na	
12 Mg	
13 Al	
14 Si	
15 P	
16 S	
17 Cl	
18 A	
19 K	
20 Ca	
21 Sc	
22 Ti	
23 V	
24 Cr	
25 Mn	
26 Fe	
27 Co	
28 Ni	
29 Cu	
30 Zn	
31 Ga	
32 Ge	
33 As	
34 Se	
35 Br	
36 Kr	
—	
47 Ag	
48 Cd	
49 In	
50 Sn	
51 Sb	
52 Te	
53 I	
54 Xe	

TABLE 18. The electron structures of the free elements 1 H—54 Xe.

X-ray level	K <sub>I</sub>	L <sub>I</sub>	L <sub>II, III</sub>	M <sub>I</sub>	M <sub>II, III</sub>	M <sub>IV, V</sub>	N <sub>I</sub>	N <sub>II, III</sub>	N <sub>IV, V</sub>	N <sub>VI, VII</sub>	O <sub>I</sub>	O <sub>II, III</sub>
Type of orbit	1 s	2 s	2 p	3 s	3 p	3 d	4 s	4 p	4 d	4 f	5 s	5 p
1 H	1											
2 He	2											
3 Li	2	1										
4 Be	2	2										
5 B	2	2	1									
6 C	2	2	2									
7 N	2	2	3									
8 O	2	2	4									
9 F	2	2	5									
10 Ne	2	2	6									
11 Na	2	2	6	1								
12 Mg	2	2	6	2								
13 Al	2	2	6	2	1							
14 Si	2	2	6	2	2							
15 P	2	2	6	2	3							
16 S	2	2	6	2	4							
17 Cl	2	2	6	2	5							
18 A	2	2	6	2	6							
19 K	2	2	6	2	6	—	1					
20 Ca	2	2	6	2	6	—	2					
21 Sc	2	2	6	2	6	1	2					
22 Ti	2	2	6	2	6	2	2					
23 V	2	2	6	2	6	3	2					
24 Cr	2	2	6	2	6	5	1					
25 Mn	2	2	6	2	6	5	2					
26 Fe	2	2	6	2	6	6	2					
27 Co	2	2	6	2	6	7	2					
28 Ni	2	2	6	2	6	8	2					
29 Cu	2	2	6	2	6	10	1					
30 Zn	2	2	6	2	6	10	2					
31 Ga	2	2	6	2	6	10	2	1				
32 Ge	2	2	6	2	6	10	2	2				
33 As	2	2	6	2	6	10	2	3				
34 Se	2	2	6	2	6	10	2	4				
35 Br	2	2	6	2	6	10	2	5				
36 Kr	2	2	6	2	6	10	2	6				
—	—	—	—	—	—	—	—	—				
47 Ag	2	2	6	2	6	10	2	6	10	—	1	
48 Cd	2	2	6	2	6	10	2	6	10	—	2	
49 In	2	2	6	2	6	10	2	6	10	—	2	1
50 Sn	2	2	6	2	6	10	2	6	10	—	2	2
51 Sb	2	2	6	2	6	10	2	6	10	—	2	3
52 Te	2	2	6	2	6	10	2	6	10	—	2	4
53 I	2	2	6	2	6	10	2	6	10	—	2	5
54 Xe	2	2	6	2	6	10	2	6	10	—	2	6

## X-ray Spectra.

the free elements completed with 10 Ne. The K-level is occupied and the L-levels are supplied with 10 electrons. For 11 Na—17 Cl the L<sub>II</sub> level is occupied and the L<sub>III</sub> level is supplied with 10 electrons outside the L<sub>II</sub> level. For 17 Cl the L<sub>III</sub> level is occupied and the L<sub>II</sub> level is supplied with 10 electrons outside the L<sub>III</sub> level. The frequency of the K $\alpha_1$  and K $\alpha_2$  lines is almost equal. For 19 K the K $\alpha_1$  and K $\alpha_2$  lines are more apparent than for 19 K. For 19 K the L<sub>II, III</sub>-levels are probably owing to the splitting of the L-levels. For 19 K the outer levels are more apparent than for 19 K. For 19 K the edges of the

elements 19 K—26 Fe when in chemical combination, and changes of the  $K\beta$ -lines have also been observed<sup>6</sup> in some cases.

In the L series spectra an effect on the L absorption edges of the elements 50 Sn—53 I has been proved.<sup>5</sup> Evidently the influence is not extended to the M-shell screened off by an 18 electron group from the valency electrons, and so the  $L\alpha_{1,2}$ -doublet, which originates from transitions from the  $M_{IV, V}$ -levels to the  $L_{III}$  level, is unaffected. Even for 35 Br an effect is absent which the author found in a preliminary investigation. For 32 Ge and for elements with lower atomic number, however, there is an obvious change of the  $L\alpha_{1,2}$ -line caused by chemical combination.<sup>7</sup>

### 3. Theoretical.

Some hypothetical interpretations have been made to explain the effects of chemical combination on the K absorption edge of mainly the elements sulphur and chlorine. Reference may here be made to a few of these. Stelling,<sup>8</sup> agreeing with Fajans,<sup>9</sup> attributed the shifts of the K limit in chlorides and sulphides to a polarization of the  $Cl^-$  and  $S^{=}$ -ions. Aoyama, Kimura and Nishina,<sup>10</sup> in opposition to Stelling, asserted that the effects were explained by the electrostatic action of adjacent ions alone. However, R. de L. Kronig<sup>11</sup> has called attention to the fact that there is a parallelism between lattice energy and polarization. In his opinion the polarization must be of secondary importance in chlorides and sulphides, which mainly crystallize in co-ordination lattices in which the distribution of adjacent ions round the emitting  $Cl^-$  or  $S^{=}$ -ions is very regular.

A more advanced theory is given by L. Pauling.<sup>12</sup> He established the necessity of taking into account not only the electrostatic crystal potential, but also the electron affinity of the crystal; the changes in x-ray absorption frequency are determined by these two important factors, but are independent of any deformation

<sup>6</sup> See J. McDonald, *Phys. Rev.* 50, 694, 1936.

<sup>7</sup> E. Gwinner, *L. c.*

<sup>8</sup> *L. c.*

<sup>9</sup> *ZS f. Phys.* 50, 531, 1928.

<sup>10</sup> *ZS f. Phys.* 44, 810, 1927.

<sup>11</sup> *Handbuch d. Phys.* 24/2, 312, 1933.

<sup>12</sup> *Phys. Rev.* 34 (2), 954, 1929.

of ions in the crystal. When an inner electron is removed from an ion in a crystal, the formula

$$h\nu = h\nu_0 + e\varphi - E_c$$

is valid in which  $\nu$  is the absorption edge of the ion in the crystal,  $\nu_0$  that of a free ion,  $e\varphi$  the electrostatic potential at the centre of the ion, and  $E_c$  the electron affinity of the crystal. The Madelung energy  $e\varphi$  is given for simple crystals by the expression:

$$e\varphi = \pm A e^2/r,$$

$r$  being the distance between adjacent ions of the charge  $e$ , and  $A$  the Madelung constant. The plus sign is intended for an anion, the minus sign for a cation. Further, Pauling has shown that for the K edge of chlorine in various crystals and of potassium in its halides  $E_c$  can be calculated from the diamagnetic susceptibility by a semi-empirical formula. For the compounds mentioned Pauling obtained fairly good accordance between observed and predicted shifts of the K edges.

J. Valasek<sup>13</sup> has made an application of Pauling's theory. From Stelling's values of the K absorption edges (frequency  $\nu_K$ ) and from his own measurements of the  $K\beta_1$ -lines (frequency  $\nu_\beta$ ) he computed for some chlorides and potassic halides the difference  $h\nu_K - h\nu_\beta$ , representing the energy required to remove an M electron from the ion in the crystal. With due regard to  $e\varphi - E_c$  these values are reduced to those for free ions and hence values for the electronic affinity of a free  $\text{Cl}^-$ -ion and for the ionization potential (for the first M electron) of a free  $\text{K}^+$ -ion are obtained. The former value agrees well with the accepted one of 3.7 volts, whereas the latter one comes out 1.5 volts too high.

Discussing theories for explaining the optical absorption by the alkaline halides, J. C. Slater and W. Shockley<sup>14</sup> have given principles for the treatment of electronic energy levels by ionic crystals. They have shown that we must adopt the simultaneous existence of discrete levels as well as of a continuum agreeably to the observation of optical continuous absorption with sharp structure. Fig. 5 gives some of the one-electron energy bands in

<sup>13</sup> Phys. Rev. 47 (2), 896, 1935.

<sup>14</sup> Phys. Rev. 50 (2), 705, 1936.

NaCl crystal, as a function of lattice spacing. The energy levels at infinite separation between the  $\text{Na}^+$ - and the  $\text{Cl}^-$ -ions are computed from known data of spectral terms, from ionization potentials for Na, and from the electron affinity for Cl, and are displaced according to the Madelung energy, which is  $3.495 e^2/d$ , where 3.495 is the Madelung number and  $d$  ( $\text{\AA}$ ) the distance between like atoms along the axis, or approximately  $(405000 \text{ cm}^{-1})/d$ . Fig. 5 also gives information about the probable

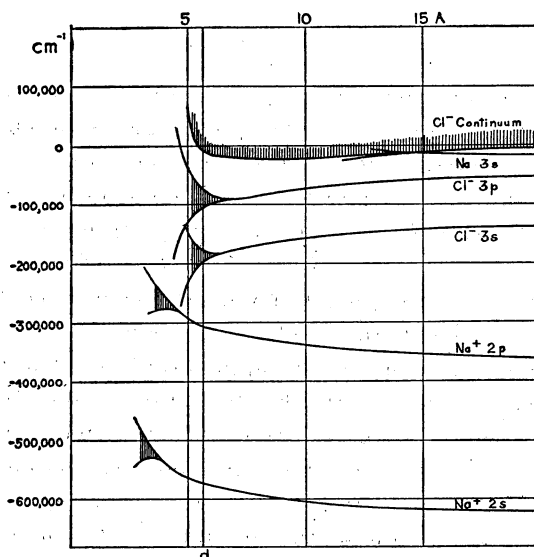

Fig. 5. One-electron energy bands in NaCl crystal. (After J. Slater and W. Shockley, *Phys. Rev.* (2), 50, 705, 1936.)

broadening of the levels at small lattice spacings when the ions overlap in the crystal. It is seen that the  $\text{Na}^+$  2p level, which is the end level for the  $K\alpha_{1,2}$ -line, is not visibly broadened in NaCl at the actual distance of 5.63  $\text{\AA}$ .

Valasek<sup>15</sup> has called attention to the fact that Pauling's theory assuming the displacement of all occupied levels to the same degree by the Madelung term alone cannot explain the changes in width and position of the emission lines, whereas the broadening of the levels in the pattern by Slater and Shockley, which goes in the opposite direction to the Madelung displacement, might

<sup>15</sup> *Phys. Rev.* (2), 51, 832, 1937.

The energy levels of the  $\text{Cl}^-$  ions are, from ionization energy for Cl, and are which is  $3.495 e^2/d$ , (AU) the distance approximately (405000) but the probable

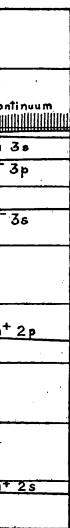

(After J. Slater and 36.)

s when the ions p level, which is ly broadened in

Pauling's theory els to the same ain the changes s the broadening ley, which goes placement, might

give a solution to this problem. The changes in width and those in wave-lengths of the emission lines are then assumed to be closely connected to each other; but this is not supported by observation on the  $K\alpha_{1,2}$ -doublet of the elements 11 Na—16 S, for which the shifts are much more obvious than the changes in the widths of the lines. Slater and Shockley's treatment was employed by Valasek<sup>15</sup> to discuss energy levels in sulphides in relation to spectroscopic data of the  $S K\beta_1$ -line and the S K absorption edge. He points out that the broadening of the upward turn of the  $\text{Cl}^-3p$  band, though not so large, would agree better with observations. Valasek<sup>16</sup> has also made use of the pattern for an interpretation of the origin of some lines for potassium and sodium chlorides, and he was able to show that certain of the weaker lines arise from transitions of valency electrons belonging to one of the ions into a K shell vacancy in the other ion.

A noticeable feature of the picture in Fig. 5 is that the bottom of the hypothetical  $\text{Cl}^-$ -continuum is fairly constant with the lattice spacing, and not displaced downwards in analogy with the discrete  $\text{Cl}^-$ -levels. This is due to the fact that the wave-function of the continuum is distributed all over the space, its charge being partly near chlorines and partly near sodiums. For the K absorption edge Pauling stated the difference between the energy-state for a free ion and for an ion in a crystal to be the Madelung energy  $e\phi$  diminished by the electronic affinity of the crystal  $E_c$ ,  $E_c$  amounting for NaCl to 5.69 volts. As the K absorption edge in Slater and Shockley's pattern would originate from the removal of a K electron to a level belonging to the  $\text{Cl}^-$ -continuum, it is evident that these workers adopt a smaller value of  $E_c$ .

On this interesting point a value of the NaCl K absorption edge could furnish some information, and therefore the author made a preliminary measurement of this hitherto uninvestigated edge. The tube constructed for primary x-rays was provided with a silver target. The absorbing NaCl screen was prepared on a  $0.5 \mu$  thick aluminium foil. A gypsum crystal as grating gave, in the smallest spectrograph, a dispersion in the first order on the spectrogram of  $19.8 \text{ XU/mm}$ . The edge was measured on

<sup>16</sup> Phys. Rev. (2), 53, 274, 1938.

the photometer-curves to the Ni  $K\alpha_1^{\text{VII}}$ -line as reference-line lying at its long-waved side. The following wave-length resulted:

NaCl: K absorption edge 11498 XU.

The corresponding energy value  $8,697,200 \text{ cm}^{-1}$  minus the energy of the  $K\alpha_{1,2}$ -line ( $\lambda = 11,884.5 \text{ XU}$ )  $8,414,300 \text{ cm}^{-1}$ , or numerically  $8,697,200 - 8,414,300 = 282,900 \text{ cm}^{-1}$ , is the energy required to remove a 2p electron in the crystal. As the  $\text{Na}^+$  2p-level means the ionization potential for a 2p electron minus the Madelung term  $381,000 - 72,000 = 309,000 \text{ cm}^{-1}$ , the factor  $E_c$  will take the value  $26,000 \text{ cm}^{-1}$ , or 3.2 volts. If the end-level of the K electron lies in the  $\text{Cl}^-$ -continuum, this must be extended further down than is sketched in the picture by Slater and Shockley.

We have seen that a satisfactory theory for the effect of chemical combination on x-ray emission lines has not yet been elaborated, although some attempts<sup>17</sup> have been made to explain the change of the energy levels in simple crystals. According to the theory of secular disturbance we must presume — in conformity with what happens in absorption — that when for example a free Na atom is ionized through the loss of its 3s electron the L energy levels are displaced towards smaller energy, and consequently, if the K level remains unaffected, the  $K\alpha_{1,2}$ -doublet shifts towards shorter wave-lengths. Provided the valency electron is not quite removed but is caught by a Cl atom and added to its 7 electron shell, the presence of the  $\text{Cl}^-$ -ion will again reduce to some degree the effect on the L levels in the  $\text{Na}^+$ -ion, and this reduction may run parallel to the electrostatic attraction between the ions. For a positive ion in the various crystals we might expect a negative shift of the  $K\alpha_{1,2}$ -doublet, which varies inversely to the lattice energy. In a corresponding manner the shift for an negative ion should go towards longer wave-lengths.

If these concrete conceptions are true for ionic crystals, we cannot *a priori* assume that the conditions are quite so simple for compounds in which homopolar bonds are active.

<sup>17</sup> See also D. Coster, ZS f. Phys. 25, 83, 1924.

reference-line lying  
length resulted:

XU.

$0 \text{ cm}^{-1}$  minus the  
 $3,414,300 \text{ cm}^{-1}$ , or  
 $n^{-1}$ , is the energy  
stal. As the  $\text{Na}^+$   
2p electron minus  
 $0 \text{ cm}^{-1}$ , the factor  
volts. If the end-  
uum, this must be  
picture by Slater

for the effect of  
has not yet been  
made to explain  
ystals. According  
st presume — in  
— that when for  
the loss of its 3s  
ds smaller energy,  
affected, the  $K\alpha_{1,2}$   
vided the valency  
y a Cl atom and  
the  $\text{Cl}^-$ -ion will  
e L levels in the  
l to the electro-  
sitive ion in the  
hift of the  $K\alpha_{1,2}$   
ergy. In a corre-  
on should go to-

onic crystals, we  
e quite so simple  
active.

## CHAPTER 5.

### Discussion of the Shifts.

#### 1. General Survey.

With a view to systematizing the results I have in Tables 19 and 20 collocated the shifts (in volts) for cations and anions respectively caused by the direct bonds to various atoms. Most of the compounds for which the shifts were found contain only two different kinds of atoms, and the valencies of these are set out in the tables in order to indicate the formula. For compounds which are not »normal» the shift together with the formula is given within brackets; in the following graphs lines of short dashes are drawn to points representing these substances.

We have seen in Tables 12—17 that the shift caused by bonds to a certain atom is often a permissible mean value of two or more shifts. This value is employed in the summarizing Tables 19 and 20. Thus for 12 Mg the compounds  $\text{MgF}_2$  and  $\text{MgSiF}_6$  give the same shift, and for 13 Al the compounds  $\text{AlF}_3$  and  $\text{Na}_3\text{AlF}_6$  likewise show the same effect, irrespective of the lattice in which the F-atoms affect the emitting atoms. For 14 Si the F-linkage is only represented by the results from  $\text{Na}_2\text{SiF}_6$  and  $\text{MgSiF}_6$ . The normal compound  $\text{SiF}_4$ , which is gaseous, would probably yield about the same shift when investigated in its solid state. In fact, a central atom with a high charge in a radicle, as for instance Si in the octahedral group  $\text{SiF}_6$  or S in the tetrahedral group  $\text{SO}_4$  (See Lundquist) is never affected by the cations but by the surrounding adjacent atoms alone. (This is also true for the K edge (p. 66)). Agreeable to this the oxide  $\text{SiO}_2$  and the silicates not containing Al in the anion show the same shift, and Bäcklin's value for  $\text{P}_2\text{O}_5$ , 0.89 volts (referring to red phosphorus), does not differ much from Lundquist's value for phos-

TABLE 19. The shifts (in volts) of the  $K\alpha_{1,2}$ -doublet of the cations 11 Na—16 S caused by the direct binding to the anions 5 B—53 I.

	Valency	11 Na	12 Mg	13 Al	14 Si	15 P	16 S
		+1	+2	+3	+4	+5	+6
5 B	-3		-0.06				
6 C	-4	-(0.04 Na <sub>2</sub> C <sub>2</sub> )	0.06	-0.13	-0.22		
7 N	-3	(0.04 NaN <sub>3</sub> )	0.08	0.29	0.49	-0.63	
8 O	-2		0.19	0.37	0.59	0.85	-1.18
9 F	-1	0.07	0.25	0.52	0.87		
10 Ne	0						
11 Na	-	(0)					
12 Mg	-		(0)				
13 Al	-		(0.03 Mg <sub>4</sub> Al <sub>3</sub> )	(0)			
14 Si	-4		0.05		(0)		
15 P	-3	(0.05 NaP <sub>3</sub> )	0.10	0.16		(0)	
16 S	-2	0.09	0.19	0.27	0.50	0.29	(0)
17 Cl	-1	0.11	0.30	0.48			
—	—						
34 Se	-2			0.33			
35 Br	-1	0.10	0.27				
—	—						
50 Sn	-4	0.04	0.05				
51 Sb	-3						
52 Te	-2			0.33			
53 I	-1	0.09					

TABLE 20. The shifts (in volts) of the  $K\alpha_{1,2}$ -doublet of the anions 13 Al—16 S caused by the direct binding to the cations 11 Na—16 S.

	Valency	13 Al	14 Si	15 P	16 S
		-	-4	-3	-2
11 Na	+1				
12 Mg	+2	+(0.07 Mg <sub>4</sub> Al <sub>3</sub> )	+0.15	+(0.01 NaP <sub>3</sub> )	+0.19
13 Al	+3	(0)		0.17	0.27
14 Si	+4		(0)	0.29	0.21
15 P	+5			(0)	0.16
16 S	+6				0.17
					(0)

phates, 0.81 volts (referring to red phosphorus). We are right in adopting Lundquist's values for the fluorescent lines of phosphates, 0.85 volts (referring to white phosphorus), and of sulphates 1.18 volts as representative of the P-O-bond and of the S-O-bond respectively. The O-bond to the elements 11 Na—14 Si is represented by the shifts for oxides and hydroxides.

The values for MgS and Al<sub>2</sub>S<sub>3</sub> in Table 20 also emanate from Lundquist.

We note that the shifts are calculated in relation to the pure element in a *crystalline* state; rightly the  $K\alpha_{1,2}$ -doublet should be referred to that of the free emitting atom, as we have grounds for assuming that the identical atoms in the lattice of the pure element affect each other so far as to the L<sub>II, III</sub>-levels. However, some reasons favour the belief that this influence is very slight. For the metals 11 Na—13 Al it is seen (Tables 19 and 20) that a partial substitution of Mg for Al as in Mg<sub>4</sub>Al<sub>3</sub>, as well as a partial substitution of Sn for Mg as in Mg<sub>2</sub>Sn, gives rise to a very small shift. As the effect on the L levels of the Al-Al-bonds differs very little from that of the Mg-Al-bonds, it is also probable that the Al-Al-bonds themselves slightly influence the L electrons. Moreover this may also be true for the Mg-Mg and for the Na-Na-bonds. Further support for our assumption is furnished by the fact that the different allotropic forms of phosphorus, viz. white phosphorus and metallic phosphorus, agree in respect of the  $K\alpha_{1,2}$ -doublet within the limits of error — in any case the difference is inconsiderable — in spite of different lattices, cubic for white and rhombohedral for metallic phosphorus. In this there is an important difference between the P  $K\alpha_{1,2}$ -doublet and the P K absorption edge, the edge for metallic phosphorus being shifted so much as 2.0 volts towards shorter wave-lengths in relation to that for white phosphorus.<sup>1</sup> It may be mentioned as a comparison that the analogous shift for phosphates amounts to 9.7 volts. So it seems as if the effect of combination between P-atoms — the nature of the linkage may be chiefly homopolar — is in the first place concentrated to the outer levels. We shall later see how the shifts for cations come out small when the combining elements are in close proximity in the same (second) horizontal row in the periodic table or when the atomic structures of the elements are most identical.

In Chapter 4 we were led to the simple assumption that the  $K\alpha_{1,2}$ -doublet has a smaller wave-length in positive ions but greater wave-length in negative ions than the free atom. In fact, the experimental results indicate the validity of the conclusion:

<sup>1</sup> O. Stelling, Diss. Lund 1927.

The  $K\alpha_{1,2}$ -doublet for cations is shifted towards shorter wave-lengths, for anions towards longer wave-lengths, in relation to the doublet of the pure element.

When an emitting element in the second periodic row is combined with another situated at its right side, the shift will come out negative (decrease of the wave-length) and vice versa, the magnitude of the shifts being decided by all the characteristics of the occurring combination. Even for the alloys  $\text{NaCd}_2$ ,  $\text{Na}_4\text{Sn}$ ,  $\text{Mg}_2\text{Sn}$ ,  $\text{Mg}_2\text{Si}$  and  $\text{Mg}_4\text{Al}_3$ , the rule is confirmed, as the shifts in all cases go in the predicted direction. These alloys are considered to be chemical compounds, except  $\text{Mg}_4\text{Al}_3$ , Mg-Al alloys being characterized by mutual solubility of the constituents. Nevertheless, the Mg  $K\alpha_{1,2}$ -line for  $\text{Mg}_4\text{Al}_3$  gives a small negative shift of 0.03 volts, whereas the Al  $K\alpha_{1,2}$ -doublet shows a positive shift of 0.07 volts, which, undoubtedly, is real. Just as it is difficult to determine whether an alloy exists as a compound or as a solid solution, it is also often impossible to decide where metallic binding leaves off and homopolar begins. (It has already been mentioned that there are intermediate forms between the four principal types of compounds.) The typical metallic binding is performed by electrical attraction between *positive* ions and electron gas. If metallic combination occurred in a binary alloy it might be expected that both constituents would show negative shifts, as always in the case of positive ions. Naturally a metallic linkage is out of question in  $\text{Mg}_2\text{Si}$ , Si not being at all a true metal. In  $\text{Mg}_4\text{Al}_3$  there may be a tendency to homopolar combination by which the positive shift of the Al  $K\alpha_{1,2}$ -doublet could be explained. This is supported by the fact that Al really belongs to the class of half-metals, which are distinguished from true metals in respect of several properties; for example, half metals are strongly diamagnetic and, contrary to the true metals, conduct electricity more readily in a molten state.

We must however beware of false conclusions. The positive shift of the Al-doublet for  $\text{Mg}_4\text{Al}_3$  *could* be explained as follows: the Al-Al-bonds in the pure element cause a negative shift, the Mg-Al-bonds in  $\text{Mg}_4\text{Al}_3$  a shift in the same direction though 0.07 volts smaller. An effect of the Al-Al-bonds amounting to 0.07 volts cannot *a priori* be considered too high. Yet if it is true we must assume an appreciably higher effect of the P-P-bonds — it

is highly probable that the effects between the identical atoms in the pure element increase from 11 Na to 16 S — and we have already given reasons for assuming that the L-levels are not in any definite manner engaged in the binding mechanism in phosphorus. After all, a real positive shift of the Al-doublet in  $Mg_4Al_3$  is more likely.

The possibility is not precluded that an extended study of the  $K\alpha_{1,2}$ -doublet of Al and Si in alloys would contribute to furnishing information about the different types of combination active in intermetallic compounds, especially the intermediate forms between homopolar and metallic bonds.

As regards the K absorption edge the conditions do not seem to be so simple as for the  $K\alpha_{1,2}$ -doublet. For the edges of various sulphides A. Lindh<sup>2</sup> found values of the wave-length to lie on *both* sides of the wave-length of the pure element. For the pure element we must surely reckon with a fairly great interatomic influence of the S-atoms in the crystal. On the whole it seems as if the study of the  $K\alpha_{1,2}$ -doublet supplies more information of the effects of the bonds than does the study of the K limit, which is influenced by the binding in a more direct but also more complicated manner.

## 2. The Shifts for Cations as Function of the Atomic Number of Disturbing Anions.

In order to study the effect of different disturbing atoms on the same emitting atom as cation we have plotted in Fig. 6 the shifts from Table 19 against the atomic number of the anions, the valencies of which are indicated in the graph by numbers within brackets. From the graph it is evident that the following conclusion is essentially to be drawn:

When the emitting atom (cation) is constant, the shift of the  $K\alpha_{1,2}$ -doublet is increased with atomic number (or decreased with valency) of disturbing atoms (anions) in both the series 13 Al—17 Cl and 5 B—9 F.

Without drawing any parallels between the »affinity» of the disturbing elements and these phenomena we may say that the rule is acceptable from a chemical point of view. When an

<sup>2</sup> Diss. Lund 1923.

emitting positive ion is linked to other atoms in a crystal we have presumed that the greater lattice energy should correspond to the smaller shift and vice versa. It is possible to test the tenability of this assumption for some compounds for which values of the lattice energies are available. It may be mentioned that the lattice selection always aims at a lattice having the formation that gives off the greatest possible amount of energy outwards.<sup>3</sup> In Table 21 energies (in kcal) of several compounds computed by A. E. Arkel and J. H. de Boer<sup>4</sup> are tabulated together

TABLE 21. Lattice energies  $U$  (kcal) and shifts  $\delta V$  (volts) of the  $K\alpha_{1,2}$  doublet for the cations.

Disturbing anion	Emitting cation	11 Na		12 Mg		13 Al		14 Si	
		Valency +1		+2		+3		+4	
		U Kcal	$\delta V$ Volts	U Kcal	$\delta V$ Volts	U Kcal	$\delta V$ Volts	U Kcal	$\delta V$ Volts
53 I	-1	166	-0.09						
35 Br	-1	177	0.10	577	-0.27				
17 Cl	-1	183	0.11	595	0.30	1280	-0.48		
9 F	-1	220	0.07	705	0.25			2550	-0.87
16 S	-2	270	0.09	790	0.19				
8 O	-2			940	0.19	1810	0.37	3100	0.59
7 N	-3					2200	0.29		

with the shifts for the cations (in volts). In spite of some inconsiderable discrepancies — we must allow for errors in the shifts — this small comparison material shows that for each element the shift is qualitatively inversely proportional to the lattice energy. Thus the halides, which represent a minimum of energy, show the greatest effects, while oxides, richer in energy, give smaller shifts, etc. This is also connected with the nature of the bonds, which in the compounds with anions from 17 Cl to 13 Al and from 9 F to 5 B alters from a more ionic to a more homopolar binding.

<sup>3</sup> V. M. Goldschmidt, Chem. Ber. 60, 1263, 1927; Trans. Far. Soc. 25, 253, 1929.

<sup>4</sup> Chemische Bindung S. 66.

a crystal we  
ould correspond  
e to test the  
ds for which  
be mentioned  
e having the  
unt of energy  
al compounds  
lated together  
olts) of the

14 Si		
+ 4		
U	$\delta V$	
Kcal	Volts	
2550	- 0.87	
3100	0.59	

ite of some  
errors in the  
at for each  
ional to the  
minimum of  
er in energy,  
h the nature  
rom 17 Cl to  
c to a more

Far. Soc. 25,

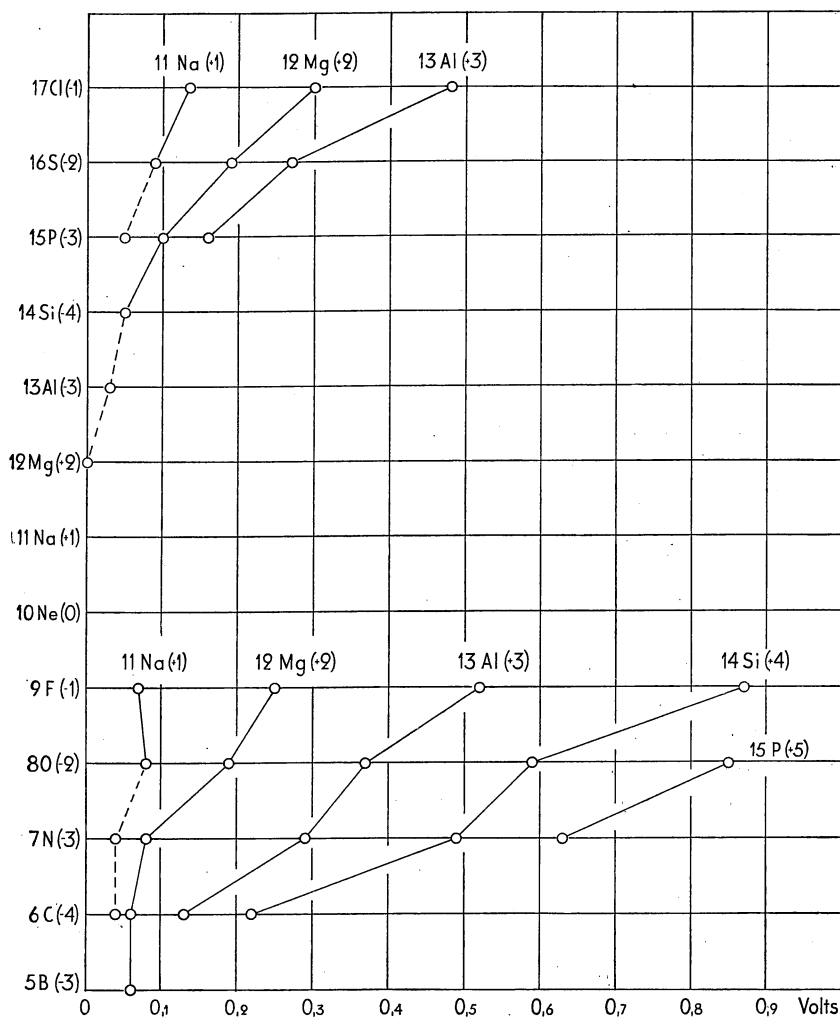

Fig. 6. The shifts (volts) of the  $K\alpha_{1,2}$  doublet for cations as a function of the atomic number of disturbing anions.

The above-mentioned rule is more obvious for emitting elements of a high valency than for those of a low valency, so that the curves tend to converge when going towards lighter affecting atoms. The shift for NaF has even come out a little smaller than that for NaOH (Fig. 6). Whether this is a nonconformity with the rule or not cannot be settled, as all effects on the  $NaK\alpha_{1,2}$

line presented in the graphs are equal within the limits of error. The one Mg-curve could be drawn through all the disturbing elements to the right of 12 Mg in the same periodic row, from 17 Cl down to the pure element itself, 12 Mg, though via the alloy  $\text{Mg}_4\text{Al}_3$ , which is not a chemical compound. Between 17 Cl and 15 P, the curve has a straight-lined course; then it bends to the vertical. The Mg-curve for the series 9 F—5 B presents a similar appearance. With regard to the errors it seems as if the upper parts (9 F—6 C and 17 Cl—15 P) of the curves might be straight lines which is most marked in the series  $\text{AlF}_3$ — $\text{Al}_4\text{C}_3$ . To this, however, the single Si-curve probably forms an exception. The shifts for  $\text{SiO}_2$  and SiC must be considered as very accurate, agreeing as they do with earlier values: for  $\text{SiO}_2$  Bäcklin found an effect of 0.57 volts, Flemberg 0.58 and the author 0.59, for SiC Flemberg and the author got the same value, 0.22 volts. As we have no reason to doubt the rather great shift for  $\text{Si}_3\text{N}_4$  (a spectrogram for this compound is reproduced in Plate II), we must conclude that a zig-zag course for the Si-curve is more probable.

Some interest attaches to the question of how the shifts for cations vary with different anions of the same valency situated in the same periodic column. This mode of viewing the effects is well-grounded, all the more so as we then compare shifts for compounds of the same or similar crystal structure. The graphs in Fig. 7 will give information about the shifts as functions of some different monovalent (9 F, 17 Cl, 35 Br, 53 I), divalent (8 O, 16 S, 34 Se, 52 Te), trivalent (7 N, 15 P) and tetravalent (6 C, 14 Si) anions. In the halides the effect of Cl on 11 Na and 12 Mg is the greatest, while F seems to affect 13 Al more than Cl does. In the Al-curve of the series 52 Te—34 Se—16 S—8 O it is obvious that the effect of S denotes minimum, the effects of O, Se and Te being about the same. Further, in the series, the relation between the effects of S and O is such that the latter with increasing valency of the emitting atom dominates more and more, the greatest difference appearing between  $\text{P}_2\text{O}_5$  (0.85 volts) and  $\text{P}_2\text{S}_5$  (0.29 volts). In other words the curves become more oblique from Na to P. The increase of obliquity is most marked when going from the Si- to the P-curve, while no increase at all occurs

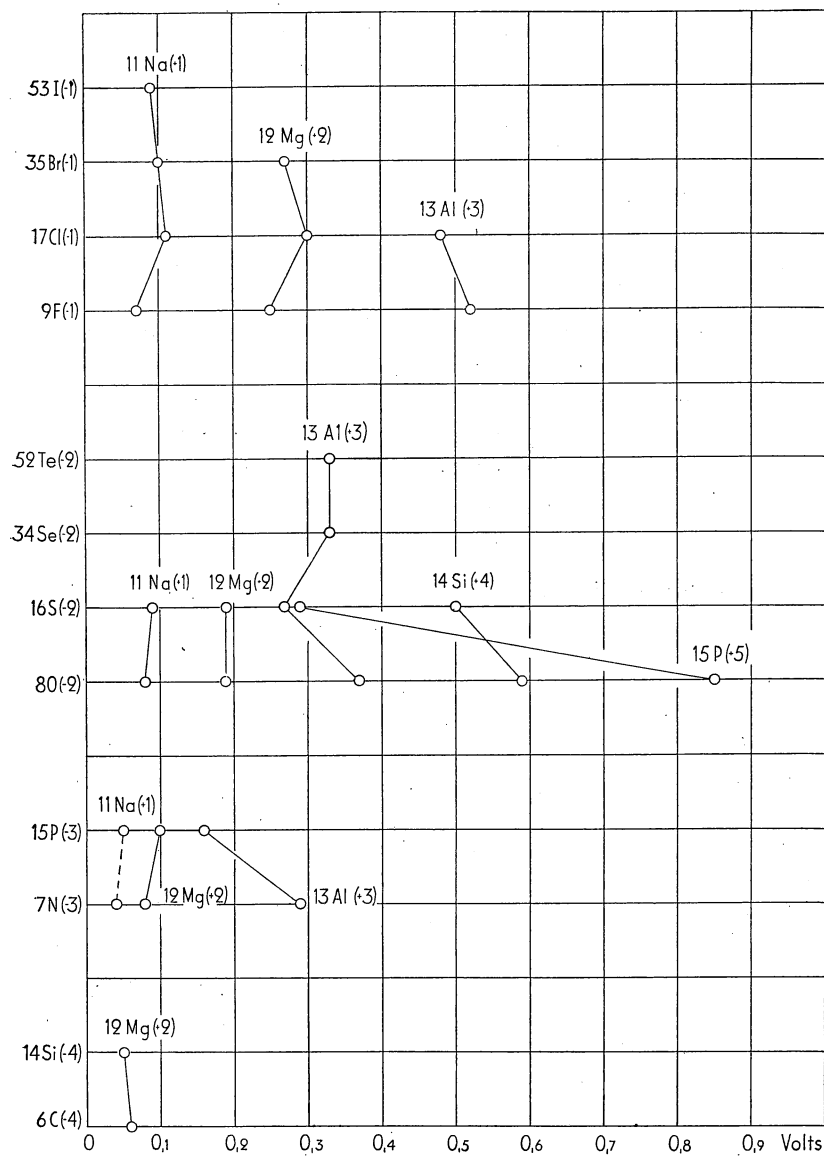

Fig. 7. The shifts (volts) of the  $K\alpha_{1,2}$ -doublet for cations as a function of disturbing anions of the same valency situated in the same periodic column.

between the Al- and the Si-curve; this is due to the fairly small difference of 0.09 volts between the shifts for  $\text{SiO}_2$  and  $\text{SiS}_2$ . (In these crystals the Si-atoms are tetrahedrally surrounded by four

O-atoms and four S-atoms respectively.<sup>5</sup>) As the phenomenon of increasing obliquity also appears between the effects of P and N, we may be justified in formulating the following conclusion:

The shifts of the  $K\alpha_{1,2}$ -doublet for cations caused by different anions of the same valency situated in the same periodic column do not as a rule differ very much, but relatively seen there is a tendency to smaller shifts when the emitting atom (cation) and the disturbing atom (anion) come to close proximity in the same (second) periodic row.

We have assumed a small effect for the identical atoms in the lattice of the pure element. It is interesting to see that under this assumption the shift for the cation in compounds between adjacent elements proves to be small. Hence it seems as if the bonds between atoms nearly equal in atomic number do not affect the L-levels to any great extent.

### 3. The Shifts as Function of the Atomic Number of the Emitting Cations.

Figs. 8 and 9 show the shifts as a function of the atomic number or the valency of the emitting elements, the curves for 6 C, 7 N, 8 O and 9 F being given in the first figure and the curves for 15 P, 16 S and 17 Cl in the second. The general tendency of these curves can be formulated thus:

The shifts increase with the atomic number (or with the valency) of the emitting atoms.

This rule, from which among a great number of values only the value for the P-doublet in  $P_2S_5$  constitutes an exception (according to our discussion above), is most obvious for the halides and becomes less marked with increasing valency of the disturbing anion so that the curves are convergent towards lighter emitting elements.

We shall first examine the O- and F-curves, which appear as lines with a slight curvature towards lighter emitting elements.<sup>6</sup>

<sup>5</sup> See ZS f. Krist., *Ergänzungsband* 1—3 (Strukturbericht).

<sup>6</sup> In a preliminary report (*Nature* 138, 1056, 1936) I assumed that these curves were parabolic, as the shifts were considered to be proportional to the valency raised to the second power of the emitting atom. Closer investigation has proved that this holds true for fluorides, whereas for

Fig. 8.  
num

W  
in the

oxides  
such a

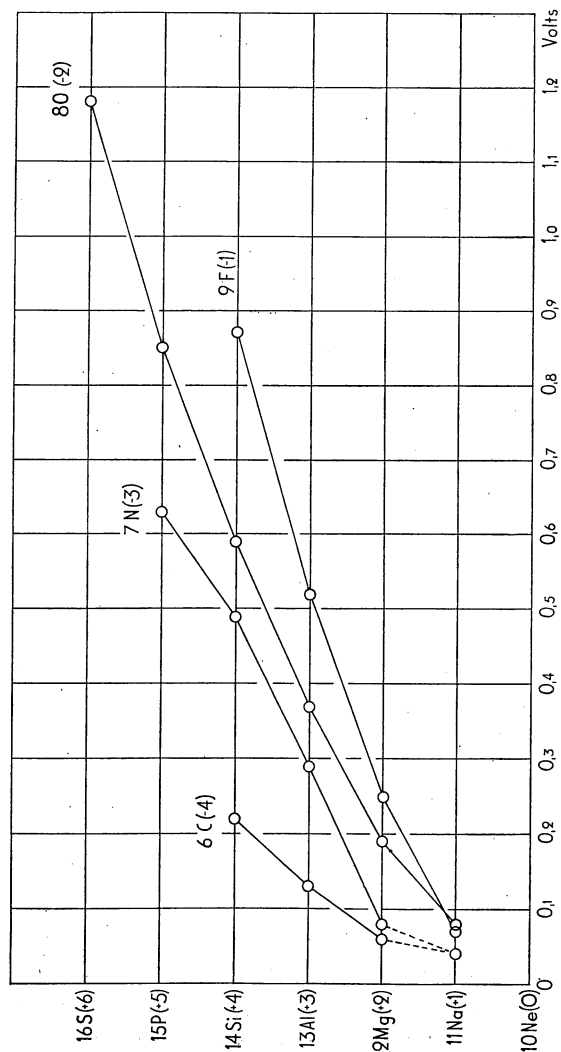

Fig. 8. The shifts (volts) of the  $K\alpha_{1,2}$ -doublet as a function of the atomic number of the emitting cations. Anions are 6 C, 7 N, 8 O and 9 F.

We shall consider the change of the chemical combination in the series of oxides from 11 Na—16 S. The compounds NaOH

oxides the conformity between observed values and values calculated from such a simple formula is not very good.

and MgO are undoubtedly ionic, but the  $\text{Al}_2\text{O}_3$ -crystal has properties which indicate a more homopolar crystal type, for instance, it is an insulator. In  $\text{SiO}_2$  at normal temperature the homopolar linkage is still more marked, though not typical. It should be of interest to bring this in line with a conception advanced by K. Fajans,<sup>7</sup> who in this oxide series and in corresponding series of fluorides and other halides reckons with a deformation of the anions with elevated charge of the cations, finding this supported by observations of molecular refractive powers. According to

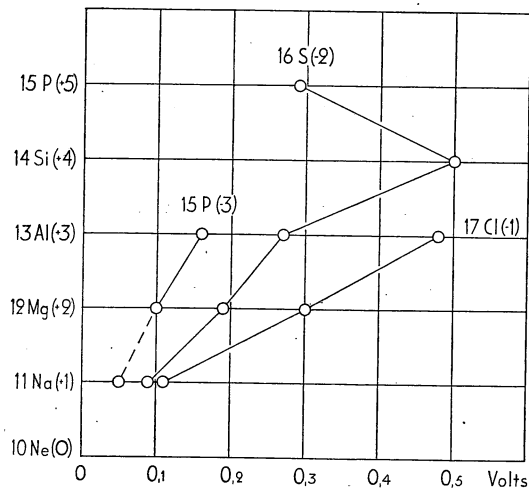

Fig. 9. The shifts (volts) of the  $K\alpha_{1,2}$ -doublet as a function of the atomic number of the emitting cations. Anions are 15 P, 16 S and 17 Cl.

Fajans the increasing polarization of the orbits involves a *continuous* transformation of the bond in the series from ionic to homopolar combination. On the other hand, the opinion has been expressed that in similar series a sharper boundary between ionic and homopolar compounds could be present. The sudden change in physical properties, for instance, between  $\text{AlF}_3$  (high melting point) and  $\text{SiF}_4$  (melting point  $-77^\circ$ ) and between  $\text{MgCl}_2$  (non-vaporizing conductor) and  $\text{AlCl}_3$  (vaporizing insulator) is assumed to give reasons for this assumption. The increasing incrustation (*Umhüllung*) of the cation by anions, thereby rendering the com-

<sup>7</sup> Handbuch d. Phys. 24/2, 1024, 1933.

crystal has properties, for instance, of the homopolar type. It should be noted that the series advanced by corresponding series of the formation of the crystal is supported. According to

However, if we regard the shift of the  $K\alpha_{1,2}$ -doublet as representing the character of the chemical forces, and in fact we have no real reason not to do so for these series, the smooth character of the curves for oxides and halides indicates that the type of binding is *continually* modified in these series. (We must however emphasize that the effect of F on the Si  $K\alpha_{1,2}$ -doublet is determined for  $K_2SiF_6$ , not for  $SiF_4$ ). As to the S-curve, this shows some anomalies — particularly  $P_2S_5$  gives a small shift which is discussed above — but the predicted change from ionic to homopolar linkage would probably already appear between MgS and  $Al_2S_3$ , of which there is no sure sign. The N-curve, in turn, has an irregular course, especially as the shift for  $Mg_3N_2$  is smaller than expected, an anomaly which could depend on experimental errors. AlN is a typical homopolar crystal type (wurtzite, ZnS), while the assignment of  $NaN_3$  and  $Mg_3N_2$  to certain compound classes is more difficult. In any case the sequence of nitrides does not import an obvious alteration from heteropolar to homopolar combination. This may also be the case for phosphides and carbides, the curves of which are continuous.

We shall try to treat the shifts for oxides and fluorides from another point of view. The curves discussed above are drawn with the shift as abscissa. Provided the shift is due to a change of the  $L_{II, III}$ -levels alone, it ought to be more correct, when comparing different emitting elements, to give the relative shifts, i. e. the shifts, divided by the absolute energy values of the L-levels. However, it is impossible to get absolute values of levels, this being a consequence of the fact pointed out by M. Siegbahn<sup>8</sup> that the ordinary selection rules are valid in x-ray absorption spectra, too. For the elements in question A. Sandström<sup>9</sup> reports that the K absorption edge of 12 Mg and 13 Al

<sup>8</sup> ZS f. Phys. 67, 567, 1931.

<sup>9</sup> Diss. Upsala 1935.

closely coincides with the  $K\beta_x$ -line that arises from transitions from the normally unoccupied  $N_{II, III}$ -level, viz. from the range of conductivity-electrons, whereas for the elements 14 Si—17 Cl the edge can be expected to coincide with the  $K\beta_1$ -line originating from transitions from the  $M_{II, III}$ -level containing 3p electrons. Thus a comparison of the absolute L-levels computed as differences between the K edges and the  $K\alpha_{1,2}$ -doublet cannot

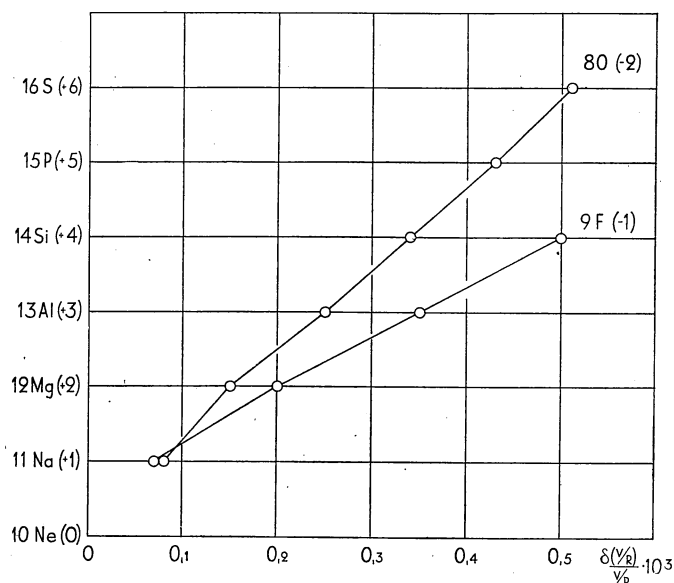
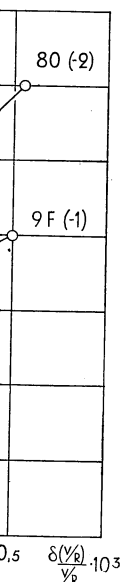

Fig. 10. The relative shifts  $\delta\nu/\nu$  of the  $K\alpha_{1,2}$ -doublet as a function of the atomic number of the emitting cations. Anions are 8 O and 9 F.

be made between the elements 11 Na—17 Cl. Instead, we are constrained to regard the shifts in relation to the  $K\alpha_{1,2}$ -doublet itself. For this purpose we choose the form of expression  $\frac{\delta(\nu/R)}{\nu/R}$  ( $\delta(\nu/R)$  differs from  $\delta V$  only by a constant), the shift  $\delta(\nu/R)$  like  $\nu/R$  of the doublet being taken from Tables 4—8 and from Lundquist's measurements of phosphates and sulphates. This ratio multiplied by  $10^3$  (or given per mill) is plotted against the atomic number or the valency of the emitting element. The F- and O-curves presented in this manner (Fig. 10) differ very little from straight lines, the slight curvature in the correspond-

from transitions  
from the range  
nts 14 Si—17 Cl  
e  $K\beta_1$ -line origi-  
containing 3p elec-  
els computed as  
-doublet cannot



a function of the  
8 O and 9 F.

Instead, we are  
the  $K\alpha_{1,2}$ -doublet  
expression  $\frac{\delta(\nu/R)}{\nu/R}$   
shift  $\delta(\nu/R)$  like  
4—8 and from  
sulphates. This  
ted against the  
ement. The F-  
(0) differ very  
the correspond-

ing curves in Fig. 8 being smoothed out. Hence the relative shifts of the  $K\alpha_{1,2}$ -doublet caused by fluorine for the emitting elements 11 Na—14 Si and by oxygen for the elements 11 Na—16 S seem to be linear functions of the atomic number or the valency of the emitting element.

A similar treatment of the shifts produced by other anions than F and O, such as N and S, turns out to be less favourable

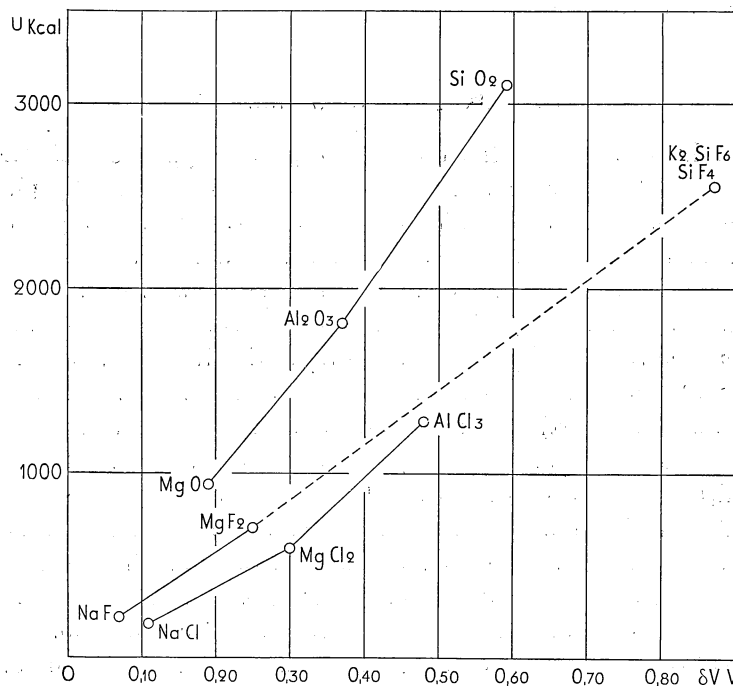

Fig. 11. The shifts  $\delta V$  (volts) of the  $K\alpha_{1,2}$ -doublet for cations as a function of the lattice energy  $U$  (kcal).

as to linearity; so the rule is probably not of general application and has maybe only occasional application.

It has been mentioned that there is apparently a qualitative relation between the shift of the  $K\alpha_{1,2}$ -doublet of the emitting cations and the lattice energy of the compound for different anions, as the shift varies inversely with the lattice energy. When for a constant anion the charge of the cation rises, the lattice energy  $U$  as well as the shift  $\delta V$  increases. Fig. 11 giving the lattice energies (kcal) from Table 21 as ordinate and the

shifts (volts) as abscissa will illustrate the parallelism between these two factors. The lattice energy of  $\text{SiF}_4$  is compared with the shift for  $\text{K}_2\text{SiF}_6$  and besides the lattice energy of  $\text{AlF}_3$  is absent — to make up for this, values for  $\text{AlCl}_3$  are given. However, from the small number of points it seems as if the shifts were simply linear functions of the lattice energy, the curves for fluorides and chlorides being nearly parallel while the oxide curve shows a smaller obliquity.

#### 4. Oxygen Compounds.

We have discussed the effect of typical oxygen combination represented by oxides and hydroxides for 11 Na—14 Si, by phosphates for 15 P, and by sulphates for 16 S. We shall now proceed to consider in some detail other oxygen compounds (Tables 12—15), beginning with those in which the emitting elements 11 Na, 12 Mg and 13 Al form positive ions. The silicates of these three elements agree in respect of the shift of the  $K\alpha_{1,2}$ -doublet fairly well with the oxides, but the series of anions  $\text{SiO}_3^-$ ,  $\text{PO}_4^{3-}$ ,  $\text{SO}_4^{2-}$  and  $\text{ClO}_4^-$  exhibits from left to right an increasing effect on the cation. This tendency, which appears from Fig. 12 ( $\text{Be}_3\text{Al}_2(\text{Si}_6\text{O}_{18})$ , beryl was investigated instead of the less common  $\text{Al}_2(\text{SiO}_3)_3$ ), tells us that in the crystal the cations formally linked to oxygen are affected by the central atom in the anions too. The effect of the  $\text{ClO}_4^-$ -ion is as great on Mg and Al as that of the  $\text{Cl}^-$ -ion, on Na even greater. The  $\text{ClO}_4^-$ -ion, like the  $\text{SO}_4^{2-}$ -ion, is a tetrahedral group within which polarized ionic or homopolar bonds are active between the central atom and the oxygen atoms. According to Goldschmidt<sup>10</sup> we must take into account the influence of the cations on the radicle in the lattice or the phenomenon called contra-polarization. This was discussed by O. Stelling<sup>11</sup> with regard to the effect of chemical combination on the K absorption edge of the central atom. He points out that owing to its high charge the central atom will polarize more than the cation so that the contra-polarizing effect does not appear in the experiments. — The cation in two other com-

<sup>10</sup> L. c.

<sup>11</sup> Diss. Lund 1927.

pounds  
gated.  
shift o  
wherea  
effects

The  
just me  
of thes  
another  
it is po  
substan

Fig. 12.  
and 13

rates c  
aid of

The  
tive ch  
We sha  
achieve  
tion of  
comple

portant  
»W  
situated  
which

<sup>12</sup> F  
(March

pounds containing a radicle,  $\text{MgCO}_3$  and  $\text{Al}(\text{NO}_3)_3$  was investigated. The  $\text{CO}_3^-$ -ion produced — as could be expected — a shift of the  $\text{Mg } K\alpha_{1,2}$ -doublet of the same magnitude as  $\text{O}$ , whereas the effect of the  $\text{NO}_3^-$ -ion on Al even exceeded the effects for other Al oxygen compounds.

The wave-length differences between the oxygen compounds just mentioned could, though small, contribute to the recognition of these compounds or to their being distinguished from one another. Thus it was proved by means of special exposures that it is possible to settle with great probability whether an aluminium substance is a silicate or a sulphate. In any case the perchlo-

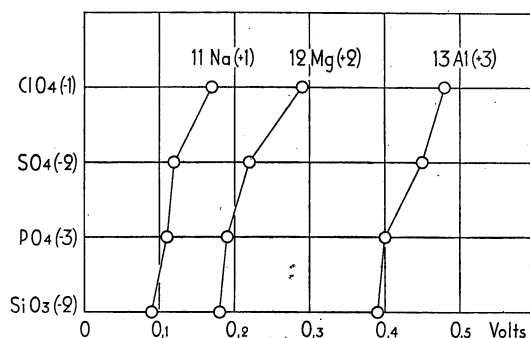

Fig. 12. The shifts (volts) of the  $K\alpha_{1,2}$ -doublet for the cations 11 Na, 12 Mg and 13 Al as a function of the disturbing anions  $\text{SiO}_3$ ,  $\text{PO}_4$ ,  $\text{SO}_4$  and  $\text{ClO}_4$ .

rates can be separated from silicates and phosphates with the aid of this analytical method.

The elements 13 Al and 14 Si can also take an electro-negative character, i. e. enter into the anion, in oxygen compounds. We shall take the silicates first. One of the most brilliant recent achievements in diffraction analysis is the complete interpretation of the structure of silicates, including those of the most complex structure. W. L. Bragg<sup>12</sup> has formulated the first important principle for the silicate structure as follows:

»Whatever the silicon to oxygen ratio, silicon always is situated within the tetrahedral group of four oxygen atoms, which is very constant in form from crystal to crystal.»

<sup>12</sup> Faraday Soc. Mon., Crystal Structure and Chemical Constitution (March 1929).

The Si—O-binding is more inclined to a homopolar than to a heteropolar character, for which argue among other signs the high heat of formation of quartz and the small distance 1.54—1.60 ÅU, between Si and O in the lattice. From the measurements it is clear that the shift of the Si  $K\alpha_{1,2}$ -doublet is the same (on an average 0.59 volts) whether the form of the anion is a space net with the charge 0 ( $\text{SiO}_2$ ), a simple tetrahedron ( $\text{SiO}_4$ ) with the charge  $-4$  ( $\text{Mg}_2\text{SiO}_4$ ), a chain  $(\text{SiO}_3)_n$  with the charge  $-2n$  ( $\text{Na}_2\text{SiO}_3$ ), or a ring ( $\text{Si}_6\text{O}_{18}$ ) with the charge  $-12$  ( $\text{Be}_3\text{Al}_2(\text{Si}_6\text{O}_{18})$ ). Even in the highly complicated structure of topaz, the anion of which is none the less ( $\text{SiO}_4$ ), the Si-atom is screened off from the influence of other atoms, including  $\text{F}^-$ -ions, by the oxygen tetrahedron and shows the usual effect of the Si—O-linkage. However, in Table 15 we notice a group of silicates, muscovite, margarite, orthoclase and anorthite, for which the shifts (0.55 volts) are below those for other silicates, the differences being small but distinct. (The difference between the doublet for  $\text{SiO}_2$  and that for muscovite could be directly seen on comparing the spectrograms). The micas muscovite (anion:  $\text{Si}_3\text{AlO}_{10}$ ) and margarite (anion:  $\text{Si}_2\text{Al}_2\text{O}_{10}$ ) are silicates with Si—O-sheets and originate from the talcs (anion:  $(\text{Si}_2\text{O}_5)_n$ ) by a partial replacement of Si-atoms by Al-atoms and the associating of positive ions in order to equalize the valency. Likewise in orthoclase (anion:  $\text{AlSi}_3\text{O}_8$ ) and anorthite (anion:  $\text{Al}_2\text{Si}_2\text{O}_8$ ), which are silicates with a 3-dimensional (Si, Al)—O-anion, some of the Si-atoms are replaced by Al. Thus the four minerals in question contain Al in the anion — contrary to other investigated silicates — and it is interesting to see that this — probably in consequence of polarization phenomena — causes a decreased shift of the Si-doublet.

Examining the aluminates, we note that a typical aluminate as  $\text{Na}_2\text{Al}_2\text{O}_4$  shows an effect of 0.23 volts, which is much smaller than that of  $\text{Al}_2\text{O}_3$ , 0.37 volts. This aluminate is assumed to contain the negative divalent complex,  $(\text{Al}_2\text{O}_4)^{=}$ , which is confirmed by its crystal structure: in the lattice Al and O form similar chains as Si and O in  $\beta$ -cristobalite  $\text{SiO}_2$ , while the Na-atoms are situated in the space.<sup>13</sup> The magnesium spinels  $\text{Al}_2(\text{MgO}_4)$  were earlier

<sup>13</sup> See ZS f. Krist., Ergänzungsband 1—3 (Strukturbericht).

interpu  
has in  
tetrah  
favou  
with t  
a sim  
attribu

Fig. 13

polar  
spinel  
is con  
Is  
to be  
not s  
H  
by ca  
W  
— O-

interpreted as aluminates of the  $Mg^{2+}$ -ion. However, x-ray analysis has indicated that in the lattice (Fig. 13) the *Mg*-atoms are tetrahedrally surrounded by four oxygen atoms, which argues in favour of a group  $(MgO_4)^{-VI}$  in the structure. In good accordance with this the shift of the Al-doublet for the spinels proves to be a simple  $Al_2O_3$ -shift. The character of this structure may be attributed to effects of contra-polarization, which means the

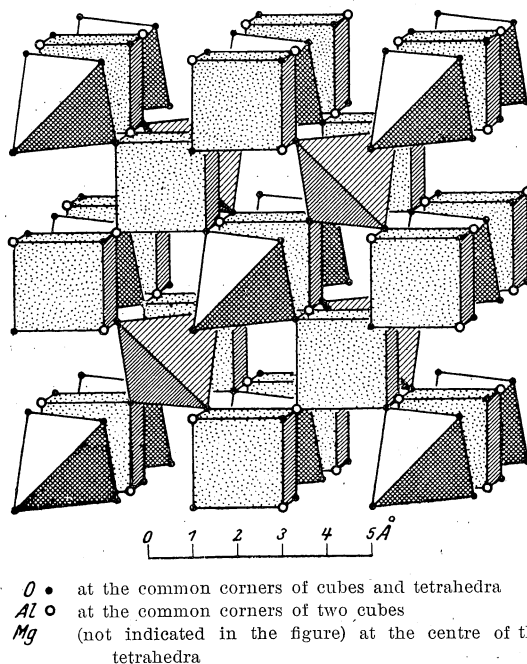

Fig. 13. The structure of  $Al_2(MgO_4)$ , spinel. (After ZS f. Krist. Ergänzungsband 1, Ewald und Hermann, Strukturbericht 1, 1913—28.)

polarizing influence of cations on a radicle-ion. In the magnesium spinels the contra-polarizing effect is so strong that a new complex is constituted round the polarizing *Mg*-atom itself.

Is this phenomenon apparent for *Mg* too? This seems actually to be case, as the shift of the *Mg*-line for spinel (0.13 volts) is not so great as that for *MgO* (0.19 volts).

Hence *Mg* and *Al* — contrary to *Si*, *P* and *S* — are affected by cations when they are central atoms in oxygen radicles.

We have seen that for silicates with 3-dimensional (*Si*, *Al*) — *O*-anion, such as orthoclase and anorthite, the shift of the *Si*-

doublet to some degree falls below the shift caused by the normal Si—O-linkage. In a corresponding manner the shift of the Al-doublet observed for these silicates (0.31 volts for orthoclase, 0.26 volts for anorthite) comes out smaller than the shift for  $\text{Al}_2\text{O}_3$  of 0.37 volts, though it is not so small as that for  $\text{Na}_2\text{Al}_2\text{O}_4$ . The slight discrepancy between the effects for orthoclase and anorthite is maybe due to an error in the determination of the wave-lengths for anorthite, the doublet-lines of which appear rather diffuse on the spectrograms.

### 5. Sulphides, Phosphides and Silicides.

Hitherto we have mainly been occupied with negative effects, which appear for cations, including central atoms in radicles. When an atom as anion emits x-rays the shift of the  $\text{K}\alpha_{1,2}$  doublet goes towards longer wave-lengths, as already mentioned. The results for some sulphides and phosphides as well as for one silicide,  $\text{Mg}_2\text{Si}$ , are given in Table 20 (p. 52). Values for  $\text{MgS}$  and  $\text{Al}_2\text{S}_3$  found by Lundquist are included in this table. For the three sulphides,  $\text{MgS}$  (ion distance 2.59 ÅU),  $\text{CaS}$  (ion distance 2.84 ÅU) and  $\text{BaS}$  (ion distance 3.18 ÅU), all crystallizing in NaCl-lattice, Lundquist found shifts of 0.27, 0.24 and 0.15 volts respectively. In this case the greater ion distance and the smaller lattice energy corresponds to the smaller effect.

In the series  $\text{MgS—Mg}_3\text{P}_2\text{—Mg}_2\text{Si}$  with the same disturbing cation Mg the shift for the anion decreases from left to right, whereas the S-doublet in  $\text{Al}_2\text{S}_3$  shows a smaller effect (0.21 volts) than the P-doublet in  $\text{AlP}$  (0.29 volts). In the series  $\text{NaP}_3\text{—Mg}_3\text{P}_2\text{—AlP}$  with an elevated charge of the disturbing cation, AlP denotes maximum for the shift of the P-doublet, while for the sulphides  $\text{Na}_2\text{S—MgS—Al}_2\text{S}_3\text{—SiS}_2\text{—P}_2\text{S}_5$  the effect on the S-doublet is maximum for  $\text{MgS}$  (0.27 volts). A rule of general application cannot be framed from these rather contradictory results. For the sulphides, experimental data as to the shifts are available for the cations as well as for the anions, but there is no striking relation-ship between the effects for cations and those for anions.

After all, it would seem that the treatment of effects for anions is more difficult than that of results for cations. In any case it is certain that other factors than the lattice energy are responsible for the effects. In the anions of sulphides, phosphides and silicides

there are in the crystals occupied levels of smaller energy than the  $L_{II, III}$ -levels; so it is to be expected that the effect of chemical combination is more complicated for anions than for cations of the elements 14 Si—16 S.

There remains to be said something about the phosphor sulphides  $P_2S_3$  and  $P_4S_3$ . When the percentage quantity of P in the sulphide increases from  $P_2S_5$  via  $P_2S_3$  to  $P_4S_3$ , the shift of the P-doublet decreases accordingly in an obvious manner, and that is also the case for the shift of the S-doublet, though this decrease is not very conspicuous (Tables 16 and 17).

### Summary.

A tube for secondary fluorescent x-rays and a spectrograph with a concave crystal grating have been used for a study of the  $K\alpha_{1,2}$ -doublet of the elements 11 Na—16 S in various compounds. Special importance has been attached to ensuring the permanence of the substances.

The effect of chemical combination on the  $K\alpha_{1,2}$ -doublet is firstly apparent as a shift of the doublet, as such, in relation to the doublet of the pure element.

Reasons are given for assuming that the identical atoms in the pure element slightly influence each other in respect of the  $K\alpha_{1,2}$ -doublet.

In all cases (even for an alloy, such as  $Mg_4Al_3$ ) the shift has proved to be negative (towards shorter wave-lengths) for cations including central atoms in radicles, and positive (towards longer wave-lengths) for anions.

When the emitting cation is constant, the shift increases with atomic number (or decreases with valency) of disturbing anions in both the series' 13 Al—17 Cl and 5 B—9 F. The increase (decrease) is more marked for emitting elements of a high valency than for those of a low valency.

The shifts for cations caused by different anions of the same valency situated in the same periodic column do not as a rule differ very much, but relatively seen there is a tendency to smaller shifts when the emitting cation and the disturbing anion come into close proximity in the same (second) periodic row.

When the disturbing anion is constant the shifts (with one

exception) increase with the atomic number (or with the valency) of the emitting cations. This increase becomes less marked with increasing valency of the disturbing anion.

The results for halides and oxides of the elements 11 Na—16 S (the relative shifts are linear functions of the atomic number or the valency of the emitting cations in these series<sup>7</sup>) indicate that the type of binding in these series<sup>7</sup> is continuously modified from ionic to homopolar. Nor in the sequences of nitrides, phosphides and carbides is a sudden change of the nature of the bond probable.

The silicates of the elements 11 Na—16 S agree with regard to the shift for the cations well with the oxides, but the series of anions  $\text{SiO}_3^-$ ,  $\text{PO}_4^{3-}$ ,  $\text{SO}_4^{2-}$  and  $\text{ClO}_4^-$  exhibits an increasing effect on the cation from left to right with increasing charge of the central atom in the oxygen radicle. On the other hand central atoms with a fairly high charge, such as Si in  $\text{SiO}_3^-$ , P in  $\text{PO}_4^{3-}$  and S in  $\text{SO}_4^{2-}$ , are not affected by the cations. On the contrary, the Al-doublet for aluminates is not shifted so much as for aluminium-oxide.

The shift of the Al-doublet for the spinels proves to be a simple  $\text{Al}_2\text{O}_3$ -shift, while the effect on the Mg-line does not seem to be so great as that for MgO, which argues in favour of a group  $(\text{MgO}_4)^{-VI}$ , the presence of which is also indicated by the crystal structure of spinel.

For silicates that contain Al in the anion the Si-doublet shows a shift to some degree smaller than that for normal silicates, while the effect on the Al-doublet falls between those for aluminium-oxide and aluminate.

For an emitting cation the shifts caused by different anions seem to be qualitatively inversely proportional to the lattice energies of the compounds. Furthermore, with a constant anion and elevated charge of the emitting cation, it seems as if the shifts were simply linear functions of the lattice energy.

A preliminary measurement of the K absorption edge of NaCl has given a wave-length of 11498 XU. This value is employed to discuss a picture by Slater and Shockley, which shows one-electron energy bands in NaCl crystal.

Na

Na Cl

with the valency)  
 less marked with  
 elements 11 Na—16 S  
 atomic number or  
 series') indicate that  
 sly modified from  
 es, phosphides and  
 he bond probable.  
 agree with regard  
 , but the series of  
 n increasing effect  
 ng charge of the  
 ther hand central  
 SiO<sub>3</sub><sup>=</sup>, P in PO<sub>4</sub><sup>=</sup>  
 On the contrary,  
 so much as for

s proves to be a  
 ne does not seem  
 favour of a group  
 ed by the crystal

Si-doublet shows  
 al silicates, while  
 se for aluminium-

y different anions  
 al to the lattice  
 a constant anion  
 ms as if the shifts

tion edge of NaCl  
 alue is employed  
 which shows one-

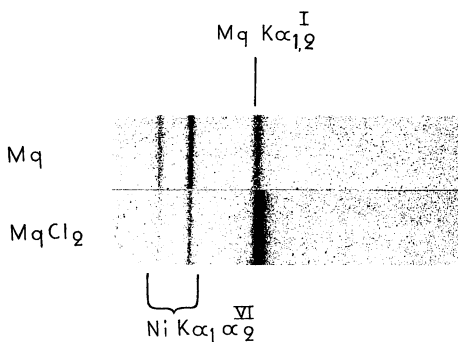

← λ

